



Standard Test Methods for Evaluating Design and Performance Characteristics of Selectorized Strength Equipment¹

This standard is issued under the fixed designation F2277; the number immediately following the designation indicates the year of original adoption or, in the case of revision, the year of last revision. A number in parentheses indicates the year of last reapproval. A superscript epsilon (ϵ) indicates an editorial change since the last revision or reapproval.

INTRODUCTION

The goal of these test methods is to provide reliable and repeatable methods for the evaluation of selectorized strength equipment. Users of these machines must recognize, however, that conformance to a standard will not necessarily prevent injuries. Like other physical activities, exercise involving strength equipment involves the risk of injury, particularly if the equipment is not maintained or used properly.

1. Scope

1.1 These test methods specify procedures and apparatus used for testing and evaluating selectorized strength equipment for compliance to Specification F2216. Both design and operational parameters will be evaluated. Where possible and applicable, accepted test methods from other recognized bodies will be used and referenced.

1.2 *Requirements*—Selectorized strength equipment is to be tested for all of the following parameters:

- 1.2.1 Stability,
- 1.2.2 Edge and corner sharpness,
- 1.2.3 Tube ends,
- 1.2.4 Weight stack travel,
- 1.2.5 Weight stack selector pin retention,
- 1.2.6 Function of adjustments and locking mechanisms,
- 1.2.7 Handgrip design and retention,
- 1.2.8 Assist mechanisms,
- 1.2.9 Foot supports,
- 1.2.10 Rope and belt systems:
 - 1.2.10.1 Static load,
 - 1.2.10.2 End fitting design,
- 1.2.11 Chain drive design,
- 1.2.12 Pulley design:
 - 1.2.12.1 Rope pulley design,
 - 1.2.12.2 Belt pulley design,
- 1.2.13 Entrapment zones,
- 1.2.14 Pull in points,
- 1.2.15 Weight stack enclosure design,

1.2.16 Loading and deflection:

- 1.2.16.1 Intrinsic loading and associated deflection,
- 1.2.16.2 Extrinsic loading and associated deflection,
- 1.2.16.3 Endurance loading, and

1.2.17 Documentation and warnings verification.

1.3 *This standard does not purport to address all of the safety concerns, if any, associated with its use. It is the responsibility of the user of this standard to establish appropriate safety and health practices and determine the applicability of regulatory limitations prior to use.*

2. Referenced Documents

2.1 *ASTM Standards*:²

- F963 Consumer Safety Specification for Toy Safety
- F1749 Specification for Fitness Equipment and Fitness Facility Safety Signage and Labels
- F2216 Specification for Selectorized Strength Equipment

2.2 *European Standards*:

- EN 957-1 Stationary Training Equipment—Part 1: General Safety Requirements and Test Methods³
- EN 957-2 Stationary Training Equipment—Part 2: Strength Training Equipment, Additional Specific Safety Requirements and Test Methods³

2.3 *UL Standard*:

- UL 1439 UL Standard for Safety Tests for Sharpness of Edges on Equipment⁴

¹ This test method is under the jurisdiction of ASTM Committee F08 on Sports Equipment and Facilities and is the direct responsibility of Subcommittee F08.30 on Fitness Products.

Current edition approved Feb. 1, 2010. Published May 2010. Originally approved in 2003. Last previous edition approved in 2003 as F2277 – 03. DOI: 10.1520/F2277-03R10.

² For referenced ASTM standards, visit the ASTM website, www.astm.org, or contact ASTM Customer Service at service@astm.org. For *Annual Book of ASTM Standards* volume information, refer to the standard's Document Summary page on the ASTM website.

³ Available from CEN Management Centre, 36 rue de Stassart, B-1050, Brussels, Belgium.

⁴ Available from Underwriters Laboratories (UL), Corporate Progress, 333 Pfingsten Rd., Northbrook, IL 60062.

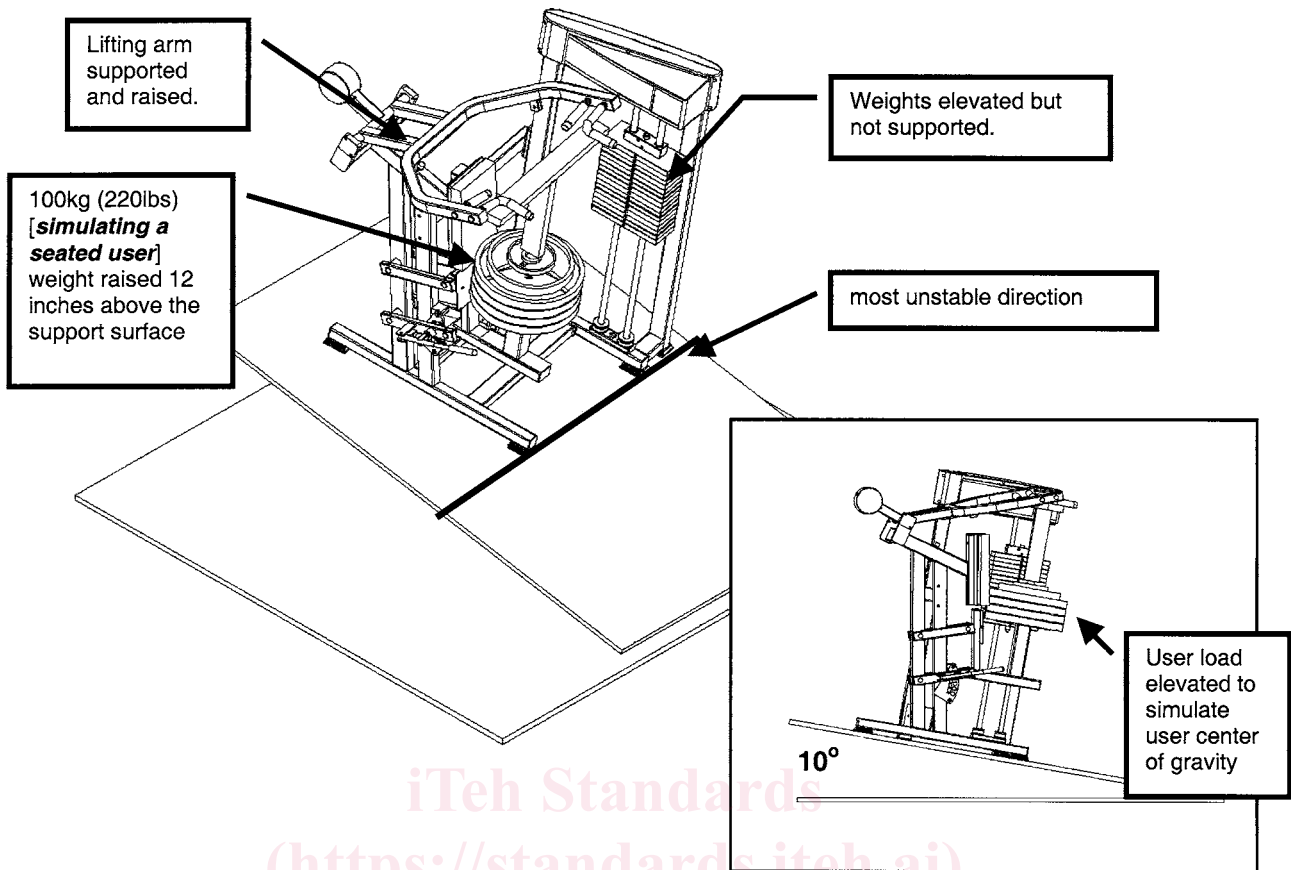

FIG. 1 Tilt Test

2.4 ANSI Standard:

ANSI B29.1 Precision Power Transmission Roller Chains, Attachments and Sprockets⁵

3. Terminology

3.1 Definitions of Terms Specific to This Standard:

3.1.1 normal operation, *n*—the operation of the selectorized strength equipment as defined by the manufacturer.

4. Significance and Use

4.1 The purpose of these test methods is to provide valid and repeatable test methods for the evaluation of selectorized strength equipment assembled and maintained according to the manufacturer's specifications. Use of these test methods in conjunction with Specification F2216 is intended to maximize the reliability of selectorized strength equipment design and reduce the risk of serious injury resulting from design deficiencies.

5. Certification

5.1 These test methods permit self-certification. It is recommended that each manufacturer employ an independent laboratory to evaluate and validate that their designs and test procedures conform and comply to these test methods and Specification F2216.

⁵ Available from American National Standards Institute (ANSI), 25 W. 43rd St., 4th Floor, New York, NY 10036.

6. Units of Measure

6.1 The values stated in SI units are to be regarded as the standard. The values in parentheses are for information only.

7. Sample Preparation

7.1 Assemble and adjust the selectorized strength equipment according to the manufacturer's instructions. Remove upholstered pads from the sample. On machines that are fully assembled, verify according to the manufacturer's instructions that all components are functioning and that they have been adjusted and aligned properly. Unless otherwise stated, the machine must pass the tests without adjustment from this initial condition. Selectorized strength equipment shall be provided with the largest weight stack offered by the manufacturer for the model to be tested.

7.2 The individual test methods will describe any variations or modifications that are required to the test sample.

8. Test Methods and Procedures

8.1 Stability:

8.1.1 Selectorized strength equipment shall be tested with and without the simulated user load in the orientation that is most obviously unstable.

8.1.2 Apparatus and Set-Up—Refer to Fig. 1. Place sample on a non-skid surface inclined at 10° in the orientation that is least stable. The sample shall rest on the supporting surface without anchoring unless the installation instructions for the machine require that the sample be anchored to the floor. If this

is the case, then anchor the specimen per the manufacturer's recommendations. Determine how the user is placed on the machine to perform the exercise (that is, seating, standing, or prone) and then determine how the user's body weight is distributed onto the user support surfaces. For the simulated use test, a method of applying a steady state load equal to 100 kg (220 lb) simulating the user's weight and its distribution in the vertical direction at the point(s) of user contact must be provided. As an example, for a seated user, the user support surface shall be adjusted to the uppermost position (if adjustable) and the center of gravity of the 100 kg (220 lb) load shall be positioned approximately 300 mm (12 in.) above the user support surface. Possible methods of providing this load include, but are not limited to, pneumatic cylinder(s) or dead weights.

8.1.3 Calibration—Using an angle measuring instrument accurate to within 0.1° , verify the non-skid surface is $10 \pm 0.5^\circ$. Calibrate the load measurement apparatus to confirm accuracy to within ± 20 N (4.5 lb) over entire 981 N (220 lb) range.

8.1.4 Procedure—Test the sample as follows:

8.1.4.1 With the sample machine (no user load applied) positioned on the tilt surface, verify that the sample does not tip over with the resistance means in the rest position.

8.1.4.2 Using the aforementioned load apparatus, distribute a vertical load equal to 100 kg (220 lb) $\pm 5\%$ in a non-impact manner to the specimen where the user contacts the machine during normal operation. (If only a portion of the user's body is supported by the machine during operation, the 100 kg (220 lb) simulated user weight shall be reduced by the appropriate amount.) Raise and support the lifting arms and weight stack to simulate the furthest point in the range of travel as encountered during normal operation of the machine by a user of 1.8 m (74 in.) stature. Verify that the sample does not tip over.

8.1.4.3 Repeat **8.1.4.1** and **8.1.4.2** with the sample oriented in any other directions of potential instability.

8.1.5 Pass/Fail Criteria—In none of the above test conditions shall the sample tip over.

8.1.6 Precision and Bias—No information is presented about either the precision or bias of test **8.1** for measuring stability since the test result is non-quantitative.

8.2 Edge Sharpness:

8.2.1 The purpose of this test is to verify that there are no edges in the accessible area that would constitute a risk of injury. Where there is uncertainty, a sharp-edge tester as specified by **UL 1439** is to be employed.

8.2.2 Apparatus and Set Up—The sample shall be set up as described in **7.1**.

8.2.3 Calibration—Calibrate sharp-edge tester per **UL 1439**.

8.2.4 Procedure—Examine the accessible areas by visual and tactile means to ensure all parts are burr-free, rounded, or otherwise insufficiently sharp to constitute a risk of injury. Wherever there may be uncertainty as to the sharpness of an edge, use the edge tester and conduct the test per **UL 1439**.

8.2.5 Pass/Fail Criteria—Use the pass/fail criteria of **UL 1439** to determine if the sample passes this test.

8.2.6 Precision and Bias—No information is presented about either the precision or bias of test **8.2** for evaluating sharp edges since the test result is non-quantitative.

8.3 Corner Sharpness:

8.3.1 This test is a visual inspection of the sample to ensure that all corners in the accessible areas are radiused or chamfered.

8.3.2 Apparatus and Set Up—The sample shall be set up as described in **7.1**.

8.3.3 Calibration—No calibration required. Visual inspection only.

8.3.4 Procedure—Inspect all corners to verify that the corners have been radiused or chamfered.

8.3.5 Pass/Fail Criteria—All corners in the accessible area shall be radiused or chamfered.

8.3.6 Precision and Bias—No information is presented about either the precision or bias of test **8.3** for evaluating corners since the test result is non-quantitative.

8.4 Tube Ends and Non-Functional Holes:

8.4.1 This test is a visual inspection of the unit to ensure that all tube ends and non-functional holes in the accessible area are closed off.

8.4.2 Apparatus and Set Up—The sample shall be set up as described in **7.1**.

8.4.3 Calibration—No calibration required. Visual inspection only.

8.4.4 Procedure—Inspect all tube ends and surfaces in the accessible area to verify that the ends and non-functional holes are closed off by other components, caps, plugs, or covers. Seat adjustment holes are exempt from this test.

8.4.5 Pass/Fail Criteria—All tube ends in the accessible area shall be closed off or the EN 957-1 test probe shall not be able to be inserted.

8.4.6 Precision and Bias—No information is presented about either the precision or bias of test in **8.4** for evaluating tube end closure since the test result is non-quantitative.

8.5 Weight Stack Travel:

8.5.1 This test is a visual inspection of the sample to ensure that the weight stack travels freely along its guide means and returns to its initial position after the displacing force has been removed.

8.5.2 Apparatus and Set Up—The sample shall be set up as described in **7.1**.

8.5.3 Calibration—No calibration required. Visual inspection only.

8.5.4 Procedure—Move the lifting arm through its range of travel and verify that the weight stack moves along a guide means in a controlled manner and returns to its initial position as the lifting arm is returned to its initial rest position.

8.5.5 Pass/Fail Criteria—The weight stack must begin and end the test in the same rest position and must not move unless it is displaced intentionally by a lifting force applied to the lifting arm.

8.5.6 Precision and Bias—No information is presented about either the precision or bias of test in **8.5** for evaluating weight stack travel since the test result is non-quantitative.

8.6 Weight Stack Selector Pin Retention:

8.6.1 This test is a visual and physical inspection of the weight stack selector pin to ensure that the design features a retention device and that it functions properly.

8.6.2 *Apparatus and Set Up*—The sample shall be set up as described in 7.1. Obtain instructions or a descriptive explanation of the function of the weight stack selector pin from the manufacturer.

8.6.3 *Calibration*—No calibration required. Visual and function inspection only.

8.6.4 *Procedure*—Inspect the weight stack selector pin and ensure that it features a retention device that will not allow the pin to be removed from the weight stack unless it is intentionally removed. Examples of retention devices include, but are not limited to, spring activated detent balls or a physical deformation of the pin and comparable retention zone on the weight plate. The operation of the retention system shall be self-evident. Insert the weight stack selector pin into a weight on the weight stack and verify that the retention mechanism functions properly.

8.6.5 *Pass/Fail Criteria*—Weight stack selector pins that do not have a retention means shall fail this test. Retention mechanisms that do not function according to the instructions provided by the manufacturer shall fail test.

8.6.6 *Precision and Bias*—No information is presented about either the precision or bias of test in 8.6 for evaluating weight stack selector pin design and function since the test result is non-quantitative.

8.7 *Adjustment and Locking Mechanism Function:*

8.7.1 This test is a visual and physical inspection of the adjustment or locking mechanisms, or both, used throughout the sample. The purpose is to ensure that the design prevents inadvertent disengagement, and that the adjustment or locking means does not interfere with the user's operation of the machine.

8.7.2 *Apparatus and Set Up*—The sample shall be set up as described in 7.1. Obtain instructions or a descriptive explanation of the function of the adjustment or locking systems used on the sample from the manufacturer.

8.7.3 *Calibration*—No calibration required. Visual and function inspection only.

8.7.4 *Procedure*—Inspect the each adjustment or locking point on the sample machine and ensure that it positively locks into position and that it cannot be disengaged unless the retention system is intentionally deactivated. Examples of positive retention devices include, but are not limited to, spring activated pins, clamps, or eccentric assemblies. Examine and make note of the positive retention system used.

8.7.4.1 Perform the exercise as described in the operation instructions and note the user's body position relative to the adjustment or locking means. At no point during the user's range of movement shall the adjustment or locking means contact the user's body. During this observation consider the effects of users of varying size or body make up. If in doubt, discuss the area of concern with the manufacturer.

8.7.5 *Pass/Fail Criteria*—Retention or locking mechanisms that do not function according to the instructions provided by the manufacturer shall fail test. Retention or locking mecha-

nisms that contact the user during normal operation of the machine shall fail the test.

8.7.6 *Precision and Bias*—No information is presented about either the precision or bias of test in 8.7 for evaluating adjustment/locking system design and function since the test result is non-quantitative.

8.8 *Handgrip Design and Retention:*

8.8.1 This test is a visual and physical inspection of the handgrips used on the sample. The purpose is to ensure that the handgrip design maintains the user's grip, remains in position, and in the case of rotating handgrips is retained against lateral movement during use of the machine.

8.8.2 *Apparatus and Set Up*—The sample shall be set up as described in 7.1. To facilitate this test a separate handgrip/lifting mechanism replicating the system used on the machine can be set up on a separate test stand. A method of applying a steady state force equal to 90 N (20.2 lb) along the longitudinal direction of the grip shall be used. A method of applying moisture, such as a spray bottle, to the grip surface shall be provided.

8.8.3 *Calibration*—Calibrate the load measurement apparatus to confirm accuracy to within ± 1 N (0.2 lb) over entire 90 N (20.2 lb) range. Verify that the measuring device is accurate to 1 mm (0.04 in.).

8.8.4 *Procedure*—Inspect the sample machine and determine if integral handgrip locations are marked on the machine and that they maintain the grip position when dry. Using the spray bottle, spray the grip surface with water. Allow the water to remain on the surface and absorb for 5 min. Reconfirm that the grip surface maintains the user's relative grip position by grasping the surface and attempting to slide your hand along the surface. An application of increasing force should be noted before your hand moves.

8.8.4.1 Inspect each non-integral handgrip on the sample machine and ensure that it is constructed from a slip resistant material and, if the handgrip is designed to rotate, that it is constrained against lateral movement along its longitudinal axis. Examples of slip resistant materials include, but are not limited to, textured plastic, rubber, foam, or vinyl. Repeat the moisture slip test described above to each grip type.

8.8.4.2 Clamp the loading means onto the handgrip with only enough pressure to ensure that the clamp does not move on the grip. Scribe or mark the specimen to set a measurement reference point. Apply 90 N (20.2 lb) of force to the loading means for 5 min. If the clamp moves on the grip surface, reposition it and apply more clamping force. Repeat the test. Do not apply excessive clamping force as this may clamp the grip against the sample and thereby nullify the test.

8.8.5 *Pass/Fail Criteria*—Handgrips that move by a dimension exceeding 2 mm (0.08 in) shall fail test. Handgrips not constructed from slip resistant materials shall fail the test.

8.8.6 *Precision and Bias*—No information is presented about either the precision or bias of test in 8.8 for evaluating handgrip design and retention since the test result is non-quantitative.

8.9 *Entrance/Exit from Machine:*

8.9.1 This test is a visual and physical inspection of the machine to determine whether or not an assist means is required and then ensure that the design functions properly.

8.9.2 *Apparatus and Set Up*—The sample shall be set up as described in 7.1. Reinstall the upholstered pads for this test. Obtain instructions or a descriptive explanation of the function of the assist mechanism(s) used on the sample from the manufacturer.

8.9.3 *Calibration*—No calibration required. Visual and function inspection only.

8.9.4 *Procedure*—Adjust the machine for the evaluator's size according to the manufacturer's instructions. The evaluator shall enter the machine and attempt to get into the exercise start position as described in the operation instructions provided by the manufacturer. The evaluator shall be able to get into and back out of the starting position with relative ease. If the lifting or user means cannot be reached by the evaluator or if the evaluator cannot get into the starting position easily, then further adjustment of the machine may be required. If this is not the case (the machine is properly adjusted per the operation instructions for the given body size of the evaluator), then an assist means that moves the lifting or user means into the direction of lifting stroke must be provided.

8.9.4.1 If an assist means is provided, then operate the mechanism and ensure that it performs as described in the operation instructions. Upon actuation of the assist means, the lifting or user means shall move into the direction of machine motion allowing the user to get into the loaded exercise start position. Upon completion of the exercise and return of the lifting or user means to the rest position, actuation of the assist means shall stop the lifting or user means prior to reaching the unloaded rest position, thereby allowing the user to exit from the loaded use position.

8.9.5 *Pass/Fail Criteria*—Machines that do not allow the user to enter or exit the machine easily shall fail the test. Assist mechanisms that do not function according to the instructions provided by the manufacturer shall fail test. Assist mechanisms that do not stop the lifting or user means far enough into the lifting stroke to allow the user to control and/or stop the final return travel of the lifting or user means shall fail the test.

8.9.6 *Precision and Bias*—No information is presented about either the precision or bias of test in 8.9 for evaluating assist mechanism design and function since the test result is non-quantitative.

8.10 *Foot Support Design:*

8.10.1 This test is a visual and physical inspection of the foot support used on the sample. The purpose is to ensure that the foot support reduces slippage.

8.10.2 *Apparatus and Set Up*—The sample shall be set up as described in 7.1. A method of applying moisture, such as a spray bottle, to the foot support surface shall be provided. The evaluator shall be wearing appropriate exercise footwear when conducting this test.

8.10.3 *Calibration*—No calibration required. Visual and function inspection only.

8.10.4 *Procedure*—Inspect the sample machine and determine if the foot supports on the machine are slip resistant when dry. Using the spray bottle, spray the foot support surface with

water. Allow the water to remain on the surface for 5 min. Rest your foot on the support surface. Reconfirm that the surface resists slippage by attempting to slide your foot along the surface. An application of increasing force should be noted before your foot moves.

8.10.5 *Pass/Fail Criteria*—Foot supports that are not constructed from slip resistant materials shall fail the test. Foot supports that do not resist slippage shall fail the test.

8.10.6 *Precision and Bias*—No information is presented about either the precision or bias of test in 8.10 for evaluating foot support design since the test result is non-quantitative.

8.11 *Belt or Rope System Design and Load Testing:*

8.11.1 This test is a visual, physical, and functional inspection of the cables, belts, or ropes and their end fittings and attachment means used on the sample to route the load from the resistance means to the user means to ensure that the design functions as intended and meets the parameters of Specification F2216.

8.11.2 *Apparatus and Set Up*—The sample shall be set up as described in 7.1. Obtain instructions or a descriptive explanation of the function of the specimen from the manufacturer. Three cable, belt, or rope specimens measuring 150 mm (5.9 in.) replicating the system installed on sample including their attachment means shall be provided for a separate loading test.

8.11.3 *Calibration*—Calibrate the load measurement apparatus to confirm accuracy to within ± 50 N (± 11 lb).

8.11.4 *Procedure:*

8.11.4.1 *Design Evaluation*—Select the minimum resistance level for the sample. Cycle the machine through several complete repetitions while observing the rope or belt attachment points. Ensure that all end fittings and attachments move freely with the lifting and resistance means and that the rope or belt does not cyclically bend or flex around these components by more than a total amount of 10° , as shown in Fig. 2.

8.11.4.2 *Load Testing*—Obtain and record from the manufacturer the maximum load amount that the belt or rope system is subjected to during operation of the sample machine through its recommended range of motion. This should take into account any multiplying effects designed into the system to increase the resistance to the user. Secure a 150 mm (5.9 in.) specimen at its end fittings or attachments points into a tensile loading apparatus capable of loading the specimen with 6 times the aforementioned maximum load. The apparatus shall be capable of recording the maximum load attained during the test. Apply a load to the system equal to 6 times the maximum load stated above. Maintain this load for 5 min. If the system fails before attaining the 6 times load, record the load attained at failure. If the system attains the load but fails before the 5 min test period has expired, record the load and the amount of time at that load. Repeat the test for each of the remaining specimens.

8.11.5 *Pass/Fail Criteria:*

8.11.5.1 *Design*—If the belt or rope cyclically flexes through an arc of more than 10° in either a combined or unidirectional amount then the cable, belt, or rope system shall fail the test.

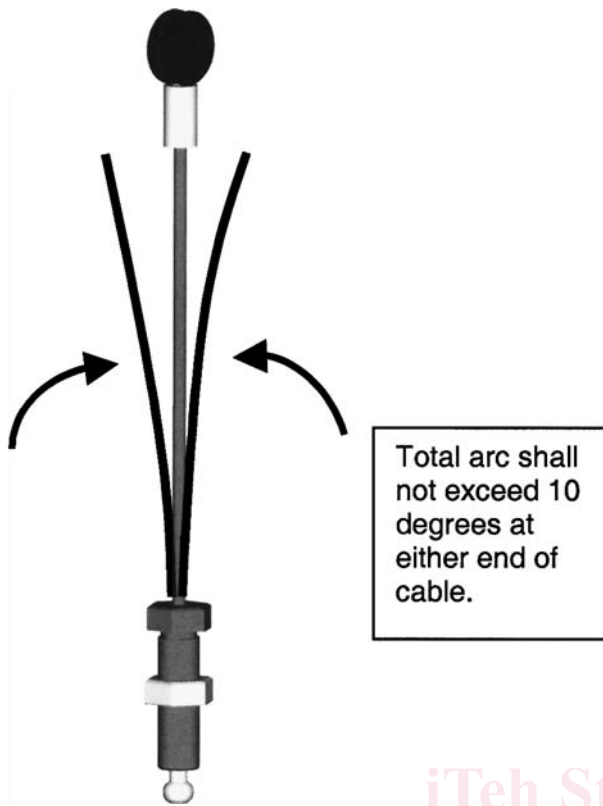

FIG. 2 Cable and Fitting Flexure

F2216. This test also verifies that the pulley enclosures prevent the ropes or belts from being inadvertently disengaged from the pulleys.

8.13.2 *Apparatus and Set Up*—The sample shall be set up as described in 7.1. Obtain instructions or a descriptive explanation of the function of the specimen from the manufacturer. A method of applying a force of 20 N (4.5 lb) perpendicularly to the rope or belt shall be provided.

8.13.3 *Calibration*—Calibrate the load measurement apparatus to confirm accuracy to within ± 0.5 N (0.1 lb). Verify that the measuring device is accurate to 1 mm (0.04 in.).

8.13.4 *Procedure*—Inspect and measure the pulley and verify that it falls within the parameters specified in Specification F2216 for the size wire rope being used on the machine. If the machine is belt driven, verify that the pulley is designed to prevent disengagement. Appropriate means would include convex or concave profile or retainment edges on each side of the pulley.

8.13.4.1 Examine the enclosures for the pulleys. Grasp the rope or belt as it exits/enters the enclosure and apply a pulling force of 20 N (4.5 lb) 90° to the direction of travel. The cable or belt shall not come off of the pulley. Repeat this process at other pulley locations on the machine.

8.13.4.2 Select the full resistance level of the sample and move the lifting means through one or more cycles at a slow and controlled rate of motion. The pulleys shall rotate as the lifting means is cycled.

8.13.5 *Pass/Fail Criteria*—Pulleys with dimensions falling outside of those specified in Specification F2216 shall fail test. Belt pulleys failing to feature a retention design shall fail the test. Enclosures that allow for disengagement of the cable or belt shall fail the test. Pulleys that do not rotate under full loading shall fail this test.

8.13.6 *Precision and Bias*—No information is presented about either the precision or bias of test in 8.13 for evaluating pulley and pulley enclosure design and function since the test result is non-quantitative.

8.14 *Entrapment Testing:*

8.14.1 This test is to evaluate the risk of injury to the user or to a third party due to inadvertent contact with a moving mechanical part and a fixed component of the machine. The results of this test determine the adequacy of spacing between components. Methodology entails insertion of a sized probe into the entrapment areas discussed in Specification F2216. It has been assumed that contact in these areas is inadvertent and therefore the test will be perpendicular and through the area in question and not articulated into all possible areas around the potential hazard.

8.14.2 *Apparatus and Set Up*—The sample shall be set up as described in 7.1 with the upholstered pads reinstalled. This test requires sized probes of 9.5 mm (0.38 in.) and 25 mm (0.98 in.) for areas most susceptible to finger injury and 60 mm (2.36 in.) for all other areas. Verify that all guards are properly positioned and secured. An apparatus capable of measuring 4.4 N (1 lb) of pulling force shall be provided.

8.14.3 *Calibration*—Calibrate the load measurement apparatus to confirm accuracy to within ± 0.5 N (0.1 lb). Verify that

8.11.5.2 *Load Testing*—If the belt or rope system fails to attain 6 times the maximum load and fails to maintain that load for 5 min then the system shall fail the test.

8.11.6 *Precision and Bias*—No information is presented about either the precision or bias of test in 8.11 for evaluating belt or rope system design since the test result is non-quantitative.

8.12 *Chain Drive Design:*

8.12.1 This test is a visual inspection of the unit to ensure that all chain sprockets are guarded or enclosed per ANSI B29.1.

8.12.2 *Apparatus and Set Up*—The sample shall be set up as described in 7.1. Verify that all guards are properly positioned and secured.

8.12.3 *Calibration*—No calibration required. Visual inspection only.

8.12.4 *Procedure*—Inspect the chain drive from the resistance device to the lifting means and ensure that it is properly guarded per ANSI B29.1.

8.12.5 *Pass/Fail Criteria*—Any portion of the chain drive that fails to meet ANSI B29.1 shall fail this test.

8.12.6 *Precision and Bias*—No information is presented about either the precision or bias of test in 8.12 for evaluating chain drive design since the test result is non-quantitative.

8.13 *Pulley and Pulley Enclosure Design:*

8.13.1 This test is a visual, physical, and functional inspection of the pulleys used on the sample to route the load from the resistance means to the user means to insure that the design functions as intended and meets the parameters of Specification