

---

---

**Small craft — Hull construction and  
scantlings —**

Part 7:

**Determination of loads for multihulls  
and of their local scantlings using  
ISO 12215-5**

iTeh STANDARD PREVIEW

*Petits navires — Construction de la coque et échantillonnage —  
Partie 7: Détermination des charges des multicoques et de leur  
échantillonnage local en utilisant l'ISO 12215-5*

<https://standards.iteh.ai/catalog/standards/sist/1a337716-db95-4aa5-bf8e-b714cc997062/iso-12215-7-2020>



**iTeh STANDARD PREVIEW**  
**(standards.iteh.ai)**

ISO 12215-7:2020

<https://standards.iteh.ai/catalog/standards/sist/1a337716-db95-4aa5-bf8e-b714cc997062/iso-12215-7-2020>



**COPYRIGHT PROTECTED DOCUMENT**

© ISO 2020

All rights reserved. Unless otherwise specified, or required in the context of its implementation, no part of this publication may be reproduced or utilized otherwise in any form or by any means, electronic or mechanical, including photocopying, or posting on the internet or an intranet, without prior written permission. Permission can be requested from either ISO at the address below or ISO's member body in the country of the requester.

ISO copyright office  
CP 401 • Ch. de Blandonnet 8  
CH-1214 Vernier, Geneva  
Phone: +41 22 749 01 11  
Email: [copyright@iso.org](mailto:copyright@iso.org)  
Website: [www.iso.org](http://www.iso.org)

Published in Switzerland

# Contents

	Page
<b>Foreword</b> .....	<b>v</b>
<b>Introduction</b> .....	<b>vi</b>
<b>1 Scope</b> .....	<b>1</b>
<b>2 Normative references</b> .....	<b>1</b>
<b>3 Terms and definitions</b> .....	<b>2</b>
<b>4 Symbols</b> .....	<b>4</b>
<b>5 Application of this document</b> .....	<b>6</b>
5.1 Materials.....	6
5.2 Limitations.....	6
5.3 Overall procedure for the application of this document.....	7
<b>6 Main dimensions, data and areas</b> .....	<b>7</b>
6.1 Dimensions and data.....	7
6.1.1 General.....	7
6.1.2 Bottom deadrise of the hulls $\beta_x$ and chine beam $B_{Cx}$ of planing multihulls.....	7
6.1.3 Wet deck bottom.....	8
6.1.4 Crossbeams.....	8
6.2 Areas.....	11
<b>7 Dimensions and pressure for panels and stiffeners under local loads</b> .....	<b>14</b>
7.1 General.....	14
7.2 Example of application on multihulls.....	14
7.2.1 Sections.....	14
7.2.2 Details on panel assessment and dimensions.....	16
7.2.3 The constant averaged pressure method.....	16
7.2.4 Other assessment and dimensioning methods.....	17
7.2.5 Panels acting as "natural" stiffeners.....	17
7.3 Other topics on panel or stiffener dimensions.....	17
<b>8 Local pressure-adjusting factors</b> .....	<b>17</b>
<b>9 Local design pressures</b> .....	<b>24</b>
9.1 General.....	24
9.2 Limits of areas.....	24
9.3 Tables defining the local design pressures for multihulls.....	24
9.4 Design pressure for trimaran floats $P_{TRFX}$ .....	27
9.4.1 Pressure reduction factors.....	27
9.4.2 Pressure.....	27
9.5 Design pressure on watertight bulkheads and integral tanks.....	27
<b>10 Further treatment of structural elements subject to local loads</b> .....	<b>27</b>
<b>11 Assessment of multihulls rudders, appendages and their wells</b> .....	<b>28</b>
<b>12 Multihull global loads</b> .....	<b>28</b>
12.1 General.....	28
12.2 Typical structural arrangements.....	28
12.3 Global load assessment.....	30
12.3.1 General.....	30
12.3.2 The simplified method.....	30
12.3.3 The enhanced method.....	31
12.4 Design stresses under global loads.....	32
12.5 Global load case GLC1: Diagonal load in quartering sea.....	32
12.6 Global load case GLC 2: Rig loads.....	33
12.7 Combination of diagonal load GLC 1 and rig load GLC 2 for sailing multihulls.....	33
12.8 Global load case GLC 3: Asymmetric broaching loads in sailing multihulls.....	33

## ISO 12215-7:2020(E)

12.9	Global load case GLC 4: Longitudinal broaching/pitchpoling.....	34
12.9.1	General.....	34
12.9.2	Full method of analysis of the buoyancy load when the craft pitchpoles.....	35
12.10	Global load case GLC 5: Longitudinal force on one hull.....	36
12.10.1	General.....	36
12.10.2	Longitudinal force.....	36
12.11	Global load case GLC 6: Bending of crossbeams connecting hulls for motor catamarans..	37
<b>13</b>	<b>Structural arrangement for supporting global loads.....</b>	<b>38</b>
<b>14</b>	<b>Multihulls used as commercial craft and workboats.....</b>	<b>38</b>
<b>15</b>	<b>Information to be included in the owner's manual.....</b>	<b>38</b>
15.1	General.....	38
15.2	Respect of maximum loaded displacement.....	38
15.3	Operational guidance.....	38
15.4	Information to take care of sandwich plating.....	38
15.5	Information required by Annex J of ISO 12215-5:2019 - for commercial craft and workboat.....	38
<b>Annex A</b> (informative)	<b>Application sheet of ISO 12215-7.....</b>	<b>39</b>
<b>Annex B</b> (informative)	<b>"Established practice" recommendations for global loads assessment using FEM methods and reporting.....</b>	<b>41</b>
<b>Annex C</b> (informative)	<b>"Established practice" details.....</b>	<b>43</b>
<b>Annex D</b> (informative)	<b>Technical background and example of torsional moment analysis with differential deflection of crossbeams.....</b>	<b>51</b>
<b>Bibliography</b> .....	<b>(standards.iteh.ai)</b>	<b>58</b>

ISO 12215-7:2020

<https://standards.iteh.ai/catalog/standards/sist/1a337716-db95-4aa5-bf8e-b714cc997062/iso-12215-7-2020>

## Foreword

ISO (the International Organization for Standardization) is a worldwide federation of national standards bodies (ISO member bodies). The work of preparing International Standards is normally carried out through ISO technical committees. Each member body interested in a subject for which a technical committee has been established has the right to be represented on that committee. International organizations, governmental and non-governmental, in liaison with ISO, also take part in the work. ISO collaborates closely with the International Electrotechnical Commission (IEC) on all matters of electrotechnical standardization.

The procedures used to develop this document and those intended for its further maintenance are described in the ISO/IEC Directives, Part 1. In particular the different approval criteria needed for the different types of ISO documents should be noted. This document was drafted in accordance with the editorial rules of the ISO/IEC Directives, Part 2 (see [www.iso.org/directives](http://www.iso.org/directives)).

Attention is drawn to the possibility that some of the elements of this document may be the subject of patent rights. ISO shall not be held responsible for identifying any or all such patent rights. Details of any patent rights identified during the development of the document will be in the Introduction and/or on the ISO list of patent declarations received (see [www.iso.org/patents](http://www.iso.org/patents)).

Any trade name used in this document is information given for the convenience of users and does not constitute an endorsement.

For an explanation of the voluntary nature of standards, the meaning of ISO specific terms and expressions related to conformity assessment, as well as information about ISO's adherence to the World Trade Organization (WTO) principles in the Technical Barriers to Trade (TBT), see [www.iso.org/iso/foreword.html](http://www.iso.org/iso/foreword.html).

This document was prepared by Technical Committee ISO/TC 188, *Small craft*.

A list of all parts in the ISO 12215 series can be found on the ISO website.

Any feedback or questions on this document should be directed to the user's national standards body. A complete listing of these bodies can be found at [www.iso.org/members.html](http://www.iso.org/members.html).

## Introduction

The reason underlying the preparation of this document is that standards and recommended practices for loads on the hull and the dimensioning of small craft differ considerably, thus limiting the general worldwide acceptability of boat scantlings. This document has been set towards the minimal requirements of the current practice.

The dimensioning according to this document is regarded as reflecting current practice, provided the craft is correctly handled in the sense of good seamanship and operated at a speed appropriate to the prevailing sea state in a safe and responsible manner, having due cognisance of the prevailing conditions.

Implementation of this document allows to achieve an overall structural strength that ensures the watertight and weathertight integrity of the craft. This document is intended to be a tool to determine the scantlings of a craft as per minimal requirements. It is not intended to be a structural design procedure.

The mechanical property data supplied as default values in this document make no explicit allowance for deterioration in service nor provide any guarantee that these values can be obtained for any particular craft.

Like the other parts of ISO 12215, this document was developed to assess the structure of recreational craft up to 24 m  $L_H$ , but it can also be used, where relevant, for non-recreational craft, workboats or yachts with an IMO load line length of up to 24 m, with the necessary critical mind.

**iTeh STANDARD PREVIEW**  
**(standards.iteh.ai)**

ISO 12215-7:2020

<https://standards.iteh.ai/catalog/standards/sist/1a337716-db95-4aa5-bf8e-b714cc997062/iso-12215-7-2020>

# Small craft — Hull construction and scantlings —

## Part 7:

# Determination of loads for multihulls and of their local scantlings using ISO 12215-5

## 1 Scope

This document defines the dimensions, local design pressures and global loads acting on multihull craft with a hull length ( $L_H$ ) or load line length of up to 24 m (see Note). It considers all parts of the craft that are assumed watertight or weathertight when assessing stability, freeboard and buoyancy in accordance with ISO 12217 (all parts). Scantlings corresponding to the local design pressures are then assessed using ISO 12215-5.

**NOTE** The load line length is defined in the OMI "International Load Lines Convention 1966/2005", it can be smaller than  $L_H$  for craft with overhangs. This length also sets up at 24 m the lower limit of several IMO conventions.

This document is applicable to multihulls built from the same materials as in ISO 12215-5, in intact condition, and of the two following types:

- recreational craft, including recreational charter vessels;
- commercial craft and workboats.

It is not applicable to multihull racing craft designed only for professional racing.

This document is applicable to the structures supporting windows, portlights, hatches, deadlights and doors.

For the complete scantlings of the craft, this document is intended to be used in conjunction with ISO 12215-8 for rudders, ISO 12215-9 for appendages of sailing craft and ISO 12215-10 for rig loads and rig attachment in sailing craft. ISO 12215-6 can be used for additional details.

Throughout this document, unless otherwise specified, dimensions are in (m), areas in ( $m^2$ ), masses in (kg), forces in (N), moments in (Nm), Pressures in ( $kN/m^2$ ) ( $1 kN/m^2 = 1 kPa$ ), stresses and elastic modulus in ( $N/mm^2$ ) ( $1 N/mm^2 = 1 MPa$ ).

## 2 Normative references

The following documents are referred to in the text in such a way that some or all of their content constitutes requirements of this document. For dated references, only the edition cited applies. For undated references, the latest edition of the referenced document (including any amendments) applies.

ISO 8666:2020, *Small craft — Principal data*

ISO 12215-5:2019, *Small craft — Hull construction and scantlings — Part 5: Design pressures for monohulls, design stress, scantlings determination*

ISO 12215-8:2009, *Small craft — Hull construction and scantlings — Part 8: Rudders*

ISO 12215-9:2012, *Small craft — Hull construction and scantlings — Part 9: Sailing craft appendages*

ISO 12215-10:2020, *Small craft — Hull construction and scantlings — Part 10: Rig loads and rig attachments in sailing craft*

## ISO 12215-7:2020(E)

ISO 12217-1:2015, *Small craft — Stability and buoyancy assessment and categorization — Part 1: Non-sailing boats of hull length greater than or equal to 6 m*

ISO 12217-2:2015, *Small craft — Stability and buoyancy assessment and categorization — Part 2: Sailing boats of hull length greater than or equal to 6 m*

ISO 12217-3:2015, *Small craft — Stability and buoyancy assessment and categorization — Part 3: Boats of hull length less than 6 m*

### 3 Terms and definitions

For the purposes of this document, the following terms and definitions apply.

ISO and IEC maintain terminological databases for use in standardization at the following addresses:

- ISO Online browsing platform: available at <https://www.iso.org/obp>
- IEC Electropedia: available at <http://www.electropedia.org/>

**3.1 multihull**  
craft with two or more hulls with a connecting *wet deck* (3.8)/crossbeams above the loaded waterline, as opposed to a tunnel boat or scow

Note 1 to entry: See Clause 6 and [Figure 2](#) for the main dimensions of a multihull.

**3.2 design categories**  
description of the sea and wind conditions for which a craft is assessed to be suitable

Note 1 to entry: The design categories are defined in ISO 12217 (all parts).

Note 2 to entry: The definitions of the design categories are in line with the European Recreational Craft Directive 2013/53/EU.

[SOURCE: ISO 12215-5:2019, 3.1.]

**3.3 loaded displacement**  
 $m_{LDC}$   
mass of water displaced by the craft, including all appendages, when in fully loaded ready for use condition

Note 1 to entry: The fully loaded ready for use condition is further defined in ISO 8666.

[SOURCE: ISO 12215-5:2019, 3.2.]

**3.4 mass in minimum operating conditions**  
 $m_{OC}$   
mass of the craft in minimum operating condition

Note 1 to entry: The minimum operating condition is further defined in ISO 8666.

**3.5 sailing craft**  
craft for which the primary means of propulsion is wind power

Note 1 to entry: It is further defined in ISO 8666.

Note 2 to entry: In this document, non-sailing craft are considered as motor craft.



[SOURCE: ISO 12215-5:2019, 3.3.]

### 3.6 beam of hull

$B_H$   
beam across the outer hulls

Note 1 to entry: The measurement of the beam of hulls is specified in ISO 8666.

### 3.7 chine beam

$B_C$   
beam at chine of planing hulls

Note 1 to entry: It is further characterized in 6.1.2.

### 3.8 wet deck

underside area of the structure connecting hulls with an area greater than 5 %  $L_H B_H$

Note 1 to entry: Some *multihulls* (3.1) have no wet deck but just crossbeams. i.e. connecting beams.

### 3.9 craft speed

$V$   
for motor craft, maximum speed in calm water and  $m_{LDC}$  condition that is declared by the manufacturer, expressed in knots

[SOURCE: ISO 12215-5:2019, 3.6.]

### 3.10 displacement craft

motor craft whose speed is such that  $V < 5\sqrt{L_{WL}}$

[SOURCE: ISO 12215-5:2019, 3.7, modified - the definition is reworded.]

### 3.11 displacement mode

mode of running of a motor craft in the sea such that its mass is mainly supported by buoyancy forces

Note 1 to entry: This is the case where the actual speed in a seaway in  $m_{LDC}$  condition is such that its speed/length ratio makes the craft behave as a *displacement craft* (3.10).

[SOURCE: ISO 12215-5:2019, 3.8, modified - in the definition, "craft" is replaced with "motor craft".]

### 3.12 planing craft

motor craft whose speed is such that  $V \geq 5\sqrt{L_{WL}}$

Note 1 to entry: This speed/length ratio limit has been arbitrarily set up in this document, but it can vary from one craft to another according to hull shape and other parameters.

[SOURCE: ISO 12215-5:2019, 3.9, modified - the definition is reworded.]

### 3.13 planing mode

mode of running of a motor craft in the sea such that a significantly part of its mass is supported by forces coming from dynamic lift due to speed in the water

Note 1 to entry: A *planing craft* (3.12) in calm water runs in planing mode, but it can be obliged to significantly reduce its speed when the sea gets worse, running in that case in *displacement mode* (3.11).

[SOURCE: ISO 12215-5:2019, 3.10, modified - the definition slightly reworded and "craft" replaced with "motor craft".]

**3.14 non-walking area**

area of the craft comprising those areas defined in the owner's manual as being both outside of the working deck and where people are not liable to stand or walk in normal or emergency operation, and those of the working deck of a *multihull* (3.1) with an inclination of more than 25° against the horizontal in the longitudinal and transverse directions

Note 1 to entry: All other areas of the working deck, cockpit bottom and superstructures are deemed to be walking areas.

**4 Symbols**

Unless specifically otherwise defined, the symbols shown in Table 1 are used in this document. The symbols are shown by group type and in alphabetical order.

Unless otherwise specified, all dimensions, measured in  $m_{LDC}$  condition, are according to ISO 12217.

**Table 1 — Symbols, dimensions, factors, parameters**

Symbol	Unit	Designation/Meaning of symbol	Reference/ Clause concerned
<b>General dimensions and data</b>			
$B_{BH}$	m	Beam between hulls as defined in Table 4	6.1, Fig 2 & Annex D
$B_C$	m	Chine beam at 0,4 $L_{WL}$ from the origin used for $k_{DYNM1}$ and $P_{BMUP,BASE}$	6.1.1, Fig 1 & Table 7
$B_{CB}$	m	Beam between centres of buoyancy	6.1, 12.5 & Fig 2
$B_{CP}$	m	Beam between upper shrouds chainplates	Annex B
$B_{WDx}$	m	Beam at the <i>inside</i> of wet deck/beam connection with hulls at section x	6.1.3 & Fig 2
$B_H$	m	Beam of hull according to 3.6	6.1 & Fig 2
$B_{nOH_i}$	m	Beam at overhang root, n = F(fwd) M(mid), A(Aft), and i = H(Hull), F(Float)	Table 11, Fig 9
$L_{nOH_i}$	m	Length of overhang, n = F(fwd) M(mid), A(Aft), and i = H(Hull), F(Float)	Table 11, Fig 9
$D_{ROH}$	m	Depth of hull at overhang root	Table 11, Fig 9
$D_{WL}$		Design Waterline plan or section	6.1.3, Figure 2
$h_{SIDE_x}$	m	Height of mid panel of cockpit side or stiffener below overflow level	Table 5 it. 10
$H_{SUP_x}$	m	Height of mid panel or stiffener above the lesser of $Z_{SDTM_x}$ or $Z_{SDAM_x}$	Table 5 it. 10
$L_{C_i}$	m	Length of crossbeam i	Table 11, Fig 9
$L_{BB}$	m	Length between main beams centre of inertia	Annex B & C
$L_H$	m	Length of hull	1
$L_{FLOAT}$	m	Length of a trimaran float	9.4 & Fig 9
$L_{WL}$	m	Length of waterline	Fig 2
$m_{LDC}$	kg	Mass of craft in fully loaded condition	3.3, 9
$m_{MO}$	kg	Mass in minimum operating condition	3.4, 11
$T_C$	m	Max canoe body draught (see Figure 2)	Fig 2, 9.3
$V$	Knots	Craft maximum speed in $m_{LDC}$ condition	3.9, Table 5 it. 2
<b>Panels, stiffeners and local dimensions and data</b>			
$A_D$	m <sup>2</sup>	Panel or stiffener supported area	Table 5 it. 9

Table 1 (continued)

Symbol	Unit	Designation/Meaning of symbol	Reference/ Clause concerned
$b$	mm	Small unsupported dimension of panel plating	Table 5 it. 9
$l$	mm	Large unsupported dimension of panel plating	Table 5 it. 9
$s$	mm	Stiffener spacing (small unsupported dimension of stiffener)	Table 5 it. 9
$l_u$	mm	Stiffener length: long unsupported dimension of stiffener (frame/stringer)	Table 5 it. 9
$Q_x$		Point at section $x$ where the pressure is assessed	Figures 2 & 3
$T_x$	m	Local canoe body draught at section $x$ (see Figure 2)	Fig 2
$x$	m	Distance of a section $x$ from aft of $L_{WL}$	Fig 2, 9.3
$Z_{Qx}$	m	Height of point $Q_x$ above $D_{WL}$ at section $x$	Fig 2, 9.3
$Z_{Tx}$	m	Height of local canoe body above $D_{WL}$ at section $x$ (usually <0)	Fig 2, 9.3
$Z_{Cx}$	m	Height of local hard chine above $D_{WL}$ at section $x$ for planing craft	Fig 2, 9.3
$Z_{SDAFx}$	m	Height of actual side/deck limit for trimaran float at section $x$	Fig 2, Table 4
$Z_{SDTMx}$	m	Height above $D_{WL}$ of the theoretical side/deck limit at section $x$	Fig 2, Table 3
$Z_{SDAMx}$	m	Height above $D_{WL}$ of the actual side/deck limit at section $x$	Fig 2, Table 3
$Z_{WDTx}$	m	Height above $D_{WL}$ of the theoretical wet deck height at section $x$	Fig 2, 9.3
$Z_{WDAx}$	m	Height above $D_{WL}$ of the actual height of wet deck at section $x$	Fig 2, 9.3
$\alpha_{LSx}, \alpha_{TSx}$	Degree	Longitudinal and transverse angle of superstructure at section $x$	Fig 2, Table 5
$\alpha_{LWDx}$ $\alpha_{LDx}$	Degree	Longitudinal (slope angle against horizontal) of wet deck or deck/cross-beam at section $x$	Fig 8, Table 5 it 9
$\beta_x$	Degree	Deadrise at section $x$ , of planing craft, not to be taken <30° nor >60°	Fig 2, 9.3
$\beta_{0,4}$	Degree	Deadrise of planing craft at section $x/L_{WL} = 0,4$	Fig 2, 9.3
<b>Calculation data, factors, etc.</b>			
$k_{AR}$	1	Area pressure distribution factor	Table 5 it. 9
$k_{BWD}$	1	Wet deck transverse pressure distribution factor	Table 5 it. 6
$k_{DC}$	1	Design category factor	Table 5 it. 1
$k_{DRx}$	1	Deadrise pressure reduction factor for planing multihulls in planing mode	Table 5 it. 8
$k_{DYNM}$	g's	Dynamic load factor for multihulls, see Figure 4	Table 5 it. 2
$k_{LDMx}$	1	Deck longitudinal pressure distribution factor for multihulls	Table 5, Fig 4
$k_{LMx}$	1	Side longitudinal pressure distribution factor for multihulls	Table 5, Fig 3
$k_{LMTx}$	1	Side longitudinal pressure distribution factor for trimaran float	9.4.1
$k_{DLMTx}$	1	Deck longitudinal pressure distribution factor for trimaran float	9.4.1
$k_{LWDx}$	1	Wet deck longitudinal pressure distribution factor	Table 5, Fig 5
$k_{SUPx}$	1	Superstructure/deckhouse pressure distribution factor for multihulls	Table 5 it. 10
$k_{Sx}$	1	Slope factor respectively $k_{SDx}$ or $k_{SDx}$ for deck and wet deck, see Figure 8	Table 5 it. 11
$k_{ZDMx}$	1	Vertical pressure correction for deck where $Z_{SDAMx} < Z_{SDTMx}$	Table 6 it. 1
$k_{ZMIx}$	1	Inner side/bottom vertical pressure correction factor in way of wet deck for sail and displacement multihulls	Table 6 it. 3
$k_{ZMOx}$	1	Outer and inner side/bottom vertical pressure correction factor clear of wet deck for sail and displacement multihulls	Table 6 it. 2
$k_{ZPMIx}$	1	Inner side/bottom vertical pressure correction factor in way of wet deck for planing multihulls in planing mode	Table 7 it. 3
$k_{ZPMOx}$	1	Outer and inner side/bottom vertical pressure correction factor clear of wet deck for planing multihulls in planing mode	Table 7 it. 2
$k_{ZWDx}$	1	Wet deck vertical pressure correction factor	Table 5 it. 7

Table 1 (continued)

Symbol	Unit	Designation/Meaning of symbol	Reference/ Clause concerned
<b>Design pressures for sailing and displacement motor multihulls</b>			
$P_{BMU\text{ BASE}}$	kN/m <sup>2</sup>	Base pressure for sailing and displacement catamarans and trimarans central hull	<a href="#">Table 6</a> it. 1
$P_{BMUx}$	kN/m <sup>2</sup>	Design pressure at lowest point of section x	<a href="#">Table 6</a> it. 1
$P_{WDx}$	kN/m <sup>2</sup>	Design wet deck/crossbeam bottom design pressure at section x	<a href="#">Table 6</a> it. 1
$P_{DMU\text{ BASE}}$	kN/m <sup>2</sup>	Base design pressure for deck and cockpit bottom	<a href="#">Table 6</a> it. 1
$P_{DMUx}$	kN/m <sup>2</sup>	Design pressure for deck and cockpit bottom at section x	<a href="#">Table 6</a> it. 1
$P_{HMUIx}$	kN/m <sup>2</sup>	Inner design pressure in way of wet deck/crossbeam at section x	<a href="#">Table 6</a> it. 3
$P_{HMUOx}$	kN/m <sup>2</sup>	Outer and inner design pressure clear of wet deck/crossbeam at section x	<a href="#">Table 6</a> it. 2
$P_{SUPMx}$	kN/m <sup>2</sup>	Superstructure and cockpit side design pressure at section x	<a href="#">Table 6</a> it. 4
<b>Design pressures for planing multihulls in planing mode</b>			
$P_{BMUP\text{ BASE}}$	kN/m <sup>2</sup>	Base bottom design pressure for planing multihulls in planing mode	<a href="#">Table 7</a> it. 1
$P_{HMUIPx}$	kN/m <sup>2</sup>	Inner design pressure in way of wet deck/crossbeam for planing multihulls in planing mode at section x	<a href="#">Table 7</a> it. 1
$P_{HMUOPx}$	kN/m <sup>2</sup>	Outer and inner design pressure for planing multihulls in planing mode clear of wet deck/crossbeam at section x	<a href="#">Table 7</a> it. 2
<b>Design pressures for trimaran floats</b>			
$P_{TRF\text{ BASE}}$	kN/m <sup>2</sup>	Base bottom pressure for trimaran float (same as for central hull)	<a href="#">Table 8</a>
$P_{TRFx}$	kN/m <sup>2</sup>	Bottom/side design pressure for trimaran floats at section x	<a href="#">Table 8</a>
<b>Stresses, shear forces and moments</b>			
$\sigma_d, \tau_d$	N/mm <sup>2</sup>	Design stress for global loads	<a href="#">Table 12</a>
$q$	N/mm	Shear flow such as $\tau = q/t$	<a href="#">Tables C.1, C.3</a>
$M_B$	Nm, kNm	Bending moment, design or ultimate	<a href="#">Annex D</a>
$M_T$	Nm, kNm	Torsional moment, design or ultimate	<a href="#">Table 14</a>
$F$	N, kN	Force, shear force	<a href="#">Tables 14, 15</a>

## 5 Application of this document

### 5.1 Materials

The materials considered in this document are the main modern building materials listed in [Clause 1](#) and Table 17 of ISO 12215-5:2019. This document may be used with other materials, including new fibres and resins, provided that they show similar cohesion, durability, resistance to marine environment and elongation at break as the ones quoted in Table 17 of ISO 12215-5:2019.

### 5.2 Limitations

The shape of multihulls entails that significant deflexions are observed without rupture of structural elements. In contrast, non-structural elements (i.e. accommodations) are sometimes stiffer, but not necessarily stronger, than the structural elements and can suffer from this difference of behaviour. This is not considered in this document provided the structural elements are strong enough. The strength and arrangements of non-structural elements are left to the responsibility and experience of the manufacturer.

On multihulls, the value of the loaded displacement  $m_{LDC}$  has a greater influence on the loads than for monohulls. Exceeding the  $m_{LDC}$  value can cause significant load increase which can transform a craft

meeting the requirements of this document into a non-conform craft, for example a lower wet deck clearance induces a much greater pressure. Overloading shall therefore be avoided, and a caution information shall be included in the owner's manual, see [15.2](#).

### 5.3 Overall procedure for the application of this document

[Table 2](#) describes, by steps, the overall procedure of this document for scantlings determination.

**Table 2 — Overall procedure for scantlings determination**

Step N°	Subject	Clause N°
1	Main dimensions, data and areas	<a href="#">6</a>
2	Dimensions of panels and stiffeners under local loads	<a href="#">7</a>
3	Local pressure adjustment factors	<a href="#">8</a>
4	Local design pressures	<a href="#">9</a>
5	Further analysis of structural elements subject to local loads	<a href="#">10</a>
6	Multihull rudders, appendages and their wells	<a href="#">11</a>
7	Multihull global loads	<a href="#">12</a>
8	Structural arrangements for supporting global loads	<a href="#">13</a>
9	Multihulls used as commercial craft and workboats	<a href="#">14</a>
10	Information to be included in the owner's manual	<a href="#">15</a>

iTeh STANDARD PREVIEW  
(standards.iteh.ai)

## 6 Main dimensions, data and areas

### 6.1 Dimensions and data

[ISO 12215-7:2020](#)

<https://standards.iteh.ai/catalog/standards/sist/1a337716-db95-4aa5-bf8e-b714cc997062/iso-12215-7-2020>

#### 6.1.1 General

The dimensions are usually the same as in ISO 12215-5:2019, many of them being as defined in ISO 8666, see [Table 1](#) and [Figures 1](#) and [2](#). The figures show sections at any longitudinal coordinate  $x$ , measured from aft of  $D_{WL}$  and some values like  $B_{WD}$ ,  $B_{BH}$ , etc. shall be taken as the average values of  $B_{WDx}$ ,  $B_{BHx}$ , etc. For clarification, data that vary with length  $x$  are followed by index  $x$ .

#### 6.1.2 Bottom deadrise of the hulls $\beta_x$ and chine beam $B_{Cx}$ of planing multihulls

[Figure 1](#) explains local chine beam  $B_{Cx}$  and deadrise determination for planing craft at any section  $x$ :

- where the bottom hulls sections of planing multihulls are approximately straight lines, the deadrise is the actual deadrise  $\beta_x$  [see [Figures 1](#) a), b) and d) and at right part of [Figure 2](#) c)], and
- where the bottom has round bilges, the deadrise  $\beta_x$  shall be measured as the angle between lowest point of the hull bottom (hull centreline) and the point where the bottom is tangent to a line angled  $50^\circ$  from horizontal [see [Figure 1](#) c) and at right part of [Figure 2](#) c)].

For planing multihulls that reach speeds allowing them to progress in planing mode ([3.13](#)), the chine beam  $B_C$  and corresponding deadrise angle  $\beta_{0,4}$ , measured at  $x = 0,4 L_{WL}$  from their aft end, are used for the determination of  $k_{DYNM1}$  and bottom pressure of planing multihulls  $P_{BMU\ BASE}$ .

Where the bottom of a planing catamaran is not symmetrical, as in [Figure 2](#) g), the bottom has an angle  $\beta_{x0}$  on the outer side and  $\beta_{xi}$  on the inner side. In the inner side, the deadrise factor  $k_{DR}$  defined in item 8 of [Table 5](#) lowers significantly the design pressure.

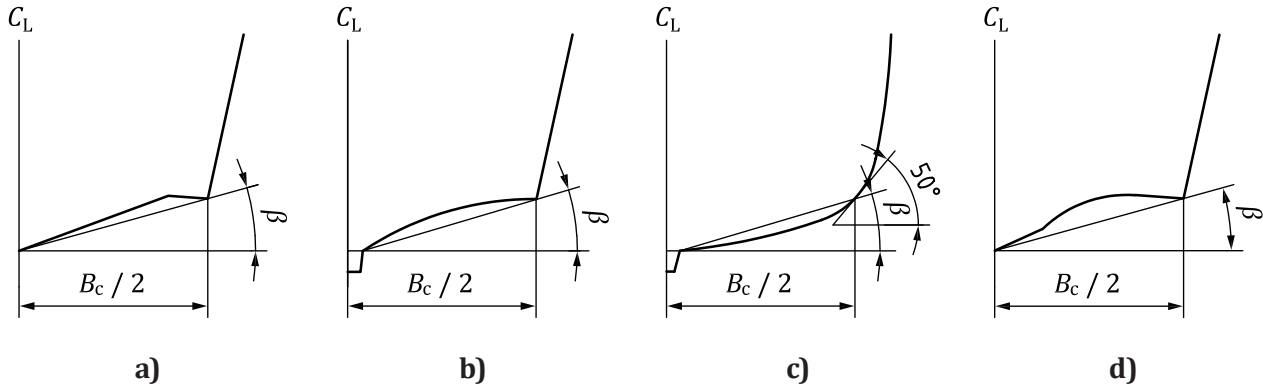

Figure 1 — Measurement of chine beam  $B_{Cx}$  and deadrise angle  $\beta_x$

### 6.1.3 Wet deck bottom

See definitions of wet deck in [Table 4](#).

For catamarans: the actual local height of the wet deck  $Z_{WDAx}$  at section  $x$  is its height above  $D_{WL}$ , see [Figure 2 b](#)). Where the wet deck bottom height is not constant, it shall be taken as the average height of 80 % of its width inside the limits of its connection with the hull plating  $B_{BWDx}$ . Where there are parts with a width greater than  $0,33 B_{WDX}$  and with a height differing by more than 10 % from  $Z_{WDAx}$ , each of these panels shall be assessed as a specific panel.  $B_{WDX}$  is the beam of the wet deck, averaged if variable, inside the angle or fairing/connection with the hulls, it is used for the calculation of  $k_{BWD}$  in item 6 of [Table 5](#).

Where different from horizontal, the angles of the wet deck bottom  $\alpha_{WDLx}$  against the horizontal increase the wet deck pressure of the wet deck or crossbeams, see item 11 of [Table 5](#) and corresponding figure.

For sailing trimarans, the wet-deck height is measured perpendicular to a sloped plan angled from  $D_{WL}$ , cutting it a  $C_L$  and at  $x = 0,5 L_{WL}$  and the float axis at key point 17 of [Figure 2 d](#)) to e) at the height  $Z_{WDT}$  above its bottom; see left part of [Figure 2 d](#)). This point 17 needs not be taken higher than the point at which the float is dipped in the water in sail configuration  $S_{C1}$  of ISO 12215-10 (apparent wind speed where the full sail area begins to be reduced).

For motor trimarans, the wet-deck height is measured perpendicular to the same sloped plan as for sailing trimarans but angled so that point 17 is taken at a height  $0,5 Z_{WDT}$  above the float's bottom.

NOTE This sloped plan for trimarans considers the "envelope" of the waterline both when the craft heels when beating upwind and when it is close to upright when running.

### 6.1.4 Crossbeams

Crossbeams for catamarans and trimarans are defined in [Table 4](#).

For local loads, the front and bottom parts of crossbeams lower than  $Z_{WDTx}$  are considered as part of the wet deck bottom, and the parts above are considered side or deck whether they are below or above  $Z_{SDTMx}$

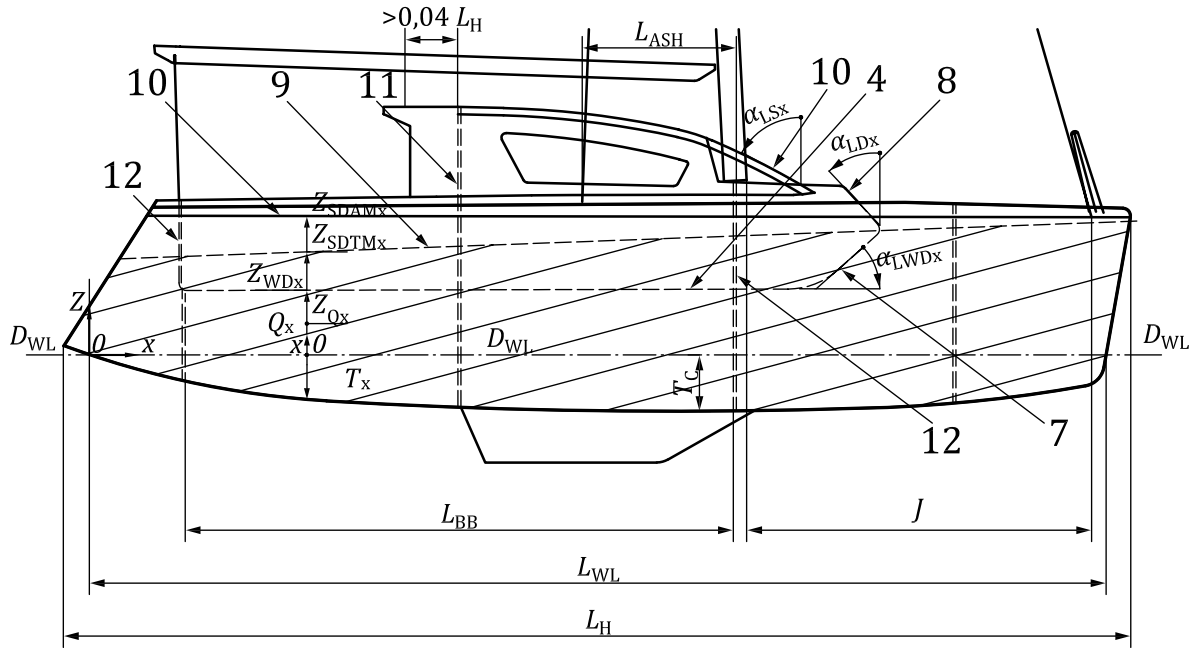

a) Typical sailing catamaran, side view

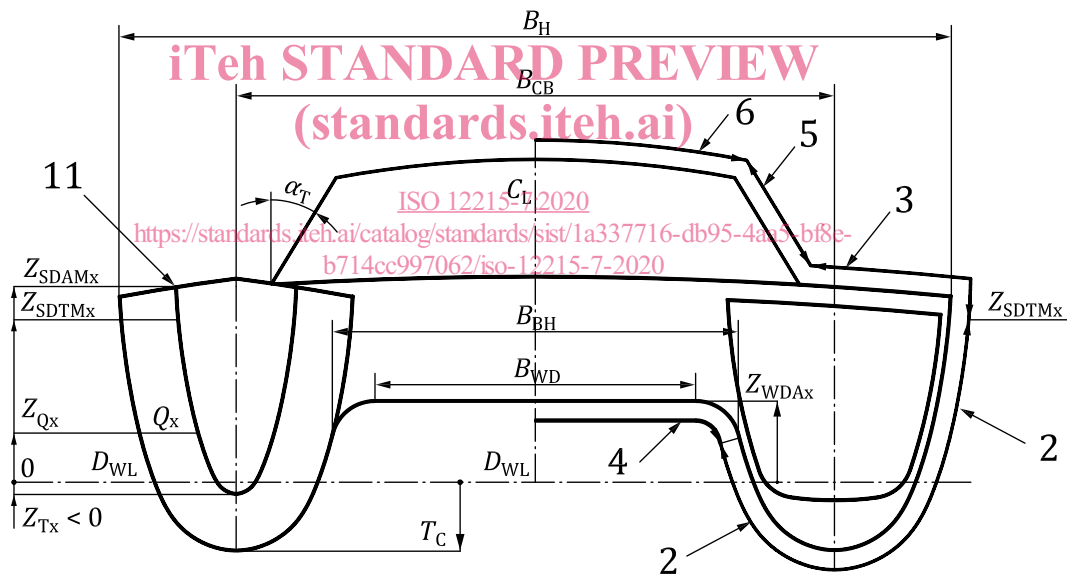

b) Typical sailing catamaran, view at main section and any section x