

---

---

**Indoor air —**

Part 6:

**Determination of organic compounds  
(VVOC, VOC, SVOC) in indoor and test  
chamber air by active sampling on  
sorbent tubes, thermal desorption and  
gas chromatography using MS or MS  
FID**

iTeh STANDARD PREVIEW  
(standards.iteh.ai)

<https://standards.iteh.ai/catalog/standards/sist/977a3188-5b2c-4b8d-bfc8-192000000000/iso-16000-6-2021>

*Air intérieur* — ISO 16000-6:2021

*Partie 6: Dosage des composés organiques (COTV, COV, COSV) dans l'air intérieur et l'air de chambre d'essai par prélèvement actif sur tubes à sorbant, désorption thermique et chromatographie en phase gazeuse avec détection MS ou MS-FID*



**iTeh STANDARD PREVIEW**  
**(standards.iteh.ai)**

ISO 16000-6:2021

<https://standards.iteh.ai/catalog/standards/sist/977a3188-5b2c-4b8d-bfc8-104f2d494e6d/iso-16000-6-2021>



**COPYRIGHT PROTECTED DOCUMENT**

© ISO 2021

All rights reserved. Unless otherwise specified, or required in the context of its implementation, no part of this publication may be reproduced or utilized otherwise in any form or by any means, electronic or mechanical, including photocopying, or posting on the internet or an intranet, without prior written permission. Permission can be requested from either ISO at the address below or ISO's member body in the country of the requester.

ISO copyright office  
CP 401 • Ch. de Blandonnet 8  
CH-1214 Vernier, Geneva  
Phone: +41 22 749 01 11  
Email: [copyright@iso.org](mailto:copyright@iso.org)  
Website: [www.iso.org](http://www.iso.org)

Published in Switzerland

# Contents

	Page
<b>Foreword</b> .....	<b>iv</b>
<b>Introduction</b> .....	<b>v</b>
<b>1 Scope</b> .....	<b>1</b>
<b>2 Normative references</b> .....	<b>1</b>
<b>3 Terms and definitions</b> .....	<b>1</b>
<b>4 Abbreviated terms</b> .....	<b>3</b>
<b>5 Principle</b> .....	<b>3</b>
<b>6 Reagents and materials</b> .....	<b>3</b>
<b>7 Apparatus</b> .....	<b>5</b>
<b>8 Conditioning and storage of sorbent tubes</b> .....	<b>9</b>
8.1 Conditioning.....	9
8.2 Storage of conditioned sorbent tubes before sampling.....	10
<b>9 Sampling</b> .....	<b>10</b>
9.1 Air sampling.....	10
9.2 Sampling volumes.....	10
9.3 Storage of loaded samples.....	11
9.4 Field blanks.....	11
<b>10 Analysis</b> .....	<b>11</b>
10.1 Determination of VOC, TVOC and SVOC.....	11
10.1.1 Analytical System.....	11
10.1.2 Identification of target compounds.....	13
10.1.3 Quantification of target compounds and compounds according to task list.....	14
10.1.4 Determining the lower limit of quantification.....	15
10.2 Identified non-target compounds and unidentified compounds.....	16
<b>11 Concentration of analytes in the sampled air</b> .....	<b>16</b>
<b>12 Performance characteristics</b> .....	<b>17</b>
<b>13 Test report</b> .....	<b>18</b>
<b>14 Quality control</b> .....	<b>19</b>
<b>Annex A (informative) Total volatile organic compounds (TVOC) and total semi-volatile organic compounds (TSVOC)</b> .....	<b>20</b>
<b>Annex B (informative) Examples of compounds detected in indoor air and from building products in test chambers</b> .....	<b>22</b>
<b>Annex C (informative) Description of sorbents</b> .....	<b>27</b>
<b>Annex D (informative) Guide on sorbent usage</b> .....	<b>28</b>
<b>Annex E (informative) Safe sampling volumes for selected organic vapours</b> .....	<b>30</b>
<b>Annex F (informative) Storage recovery of solvents on sorbent tubes</b> .....	<b>33</b>
<b>Bibliography</b> .....	<b>35</b>

## Foreword

ISO (the International Organization for Standardization) is a worldwide federation of national standards bodies (ISO member bodies). The work of preparing International Standards is normally carried out through ISO technical committees. Each member body interested in a subject for which a technical committee has been established has the right to be represented on that committee. International organizations, governmental and non-governmental, in liaison with ISO, also take part in the work. ISO collaborates closely with the International Electrotechnical Commission (IEC) on all matters of electrotechnical standardization.

The procedures used to develop this document and those intended for its further maintenance are described in the ISO/IEC Directives, Part 1. In particular, the different approval criteria needed for the different types of ISO documents should be noted. This document was drafted in accordance with the editorial rules of the ISO/IEC Directives, Part 2 (see [www.iso.org/directives](http://www.iso.org/directives)).

Attention is drawn to the possibility that some of the elements of this document may be the subject of patent rights. ISO shall not be held responsible for identifying any or all such patent rights. Details of any patent rights identified during the development of the document will be in the Introduction and/or on the ISO list of patent declarations received (see [www.iso.org/patents](http://www.iso.org/patents)).

Any trade name used in this document is information given for the convenience of users and does not constitute an endorsement.

For an explanation of the voluntary nature of standards, the meaning of ISO specific terms and expressions related to conformity assessment, as well as information about ISO's adherence to the World Trade Organization (WTO) principles in the Technical Barriers to Trade (TBT), see [www.iso.org/iso/foreword.html](http://www.iso.org/iso/foreword.html).

This document was prepared by Technical Committee ISO/TC 146, *Air quality*, Subcommittee SC 6, *Indoor air*.

This third edition cancels and replaces the second edition (ISO 16000-6:2011), which has been technically revised. The main changes compared to the previous edition are as follows:

- other sorbents than Tenax TA® are allowed to be used;
- descriptions of VVOC and SVOC measurements are included in the mandatory part of the document.

A list of all parts in the ISO 16000 series can be found on the ISO website.

Any feedback or questions on this document should be directed to the user's national standards body. A complete listing of these bodies can be found at [www.iso.org/members.html](http://www.iso.org/members.html).

## Introduction

ISO 16000-1 establishes general requirements relating to the measurement of indoor air pollutants and the important conditions to be observed before or during the sampling of individual pollutants or groups of pollutants. Aspects of the determination (sampling and analysis) and the sampling strategy of specific pollutants or groups of pollutants are specified in the subsequent parts of ISO 16000 (see Foreword).

ISO 16000-5 (dealing with VOC sampling strategy) is a link between ISO 16000-1 (a generic standard establishing the principles) and this part of ISO 16000, which deals with sampling and analytical measurements.

ISO 16017 (see [Clause 2](#) and Reference [8]) and ISO 12219 [3]-[7] also focus on measuring vapour-phase organic chemicals in air.

This document can be applied to measure vapour phase organic compounds in indoor environments that include buildings with varying designs and purposes and cabins for different modes of transport, as well as measurement in product emission test chambers. These measurements can be for a range of purposes as described in ISO 16000-1 and ISO 16000-5, therefore the requirement for the measurement may be well defined by the task descriptor or may be quite open. For example, the task may be to determine a specific list of target chemicals with a defined sampling time and sensitivity of measurement or it may be to investigate the cause of a reported and poorly understood indoor air quality problem. Depending upon the task of measurement the user of this document should select the most appropriate sampling and analytical instrumentation and conditions. This document provides that information in the normative part combined with informative guidance. [Figure 1](#) refers to the most critical parts of the standard with regard to selection of the most appropriate methodology for the task to be undertaken. Tenax TA<sup>®1</sup> only or multisorbents can be used to capture ranges of vapour phase organic compounds. Multisorbents are used for wider ranges and may improve recovery of compounds.

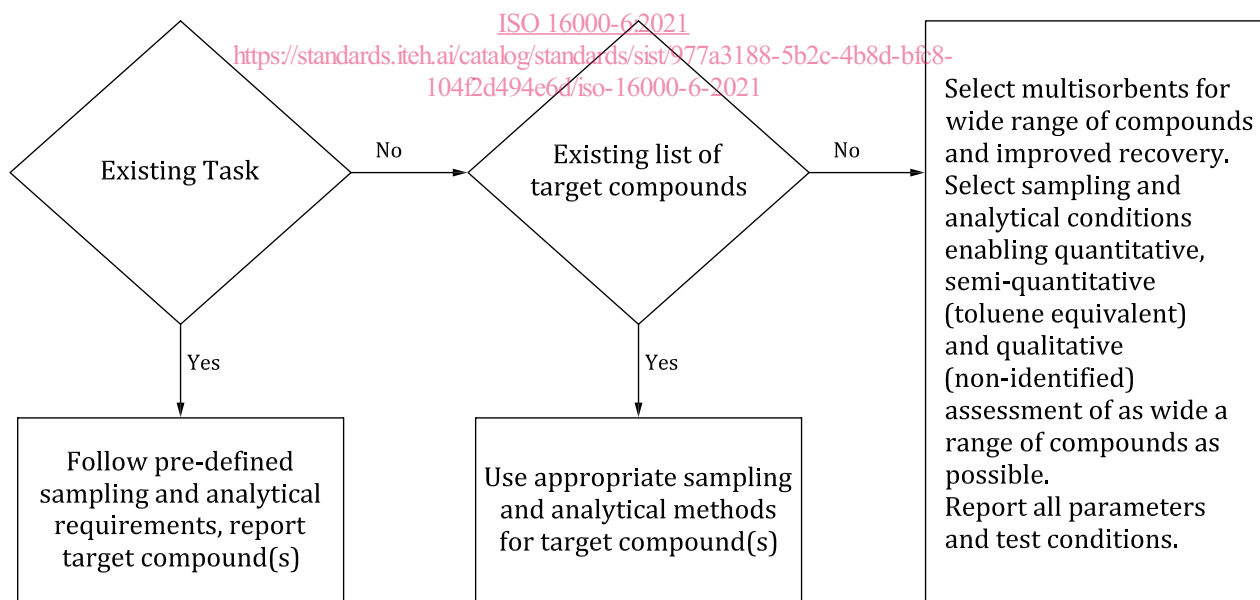

**Figure 1 — Measurement scheme showing different ways of analysing air samples depending on the respective task including target compounds**

1) Tenax TA<sup>®</sup> is a trade name of a product supplied by Buchem. This information is given for the convenience of users of this document and does not constitute an endorsement by ISO of the product named. Equivalent products may be used, if they can be shown to lead to the same results.

**iTeh STANDARD PREVIEW**  
**(standards.iteh.ai)**

ISO 16000-6:2021

<https://standards.iteh.ai/catalog/standards/sist/977a3188-5b2c-4b8d-bfc8-104f2d494e6d/iso-16000-6-2021>

# Indoor air —

## Part 6:

# Determination of organic compounds (VVOC, VOC, SVOC) in indoor and test chamber air by active sampling on sorbent tubes, thermal desorption and gas chromatography using MS or MS FID

## 1 Scope

This document specifies a method for determination of volatile organic compounds (VOC) in indoor air and in air sampled for the determination of the emission from products or materials used in indoor environments (according to ISO 16000-1) using test chambers and test cells. The method uses sorbent sampling tubes with subsequent thermal desorption (TD) and gas chromatographic (GC) analysis employing a capillary column and a mass spectrometric (MS) detector with or without an additional flame ionisation detector (FID)<sup>[13]</sup>.

The method is applicable to the measurement of most GC-compatible vapour-phase organic compounds at concentrations ranging from micrograms per cubic metre to several milligrams per cubic metre. Many very volatile organic compounds (VVOC) and semi-volatile organic compounds (SVOC) can be analysed depending on the sorbents used.

## 2 Normative references

The following documents are referred to in the text in such a way that some or all of their content constitutes requirements of this document. For dated references, only the edition cited applies. For undated references, the latest edition of the referenced document (including any amendments) applies.

ISO 16000-1, *Indoor air — Part 1: General aspects of sampling strategy*

EN 13137, *Workplace atmospheres – Pumps for personal sampling of chemical and biological agents – Requirements and test methods*

## 3 Terms and definitions

For the purposes of this document, the following terms and definitions apply.

ISO and IEC maintain terminological databases for use in standardization at the following addresses:

— ISO Online browsing platform: available at <https://www.iso.org/obp>

— IEC Electropedia: available at <https://www.electropedia.org/>

### 3.1

#### semi-volatile organic compound SVOC

organic compound eluting after n-hexadecane on a gas chromatographic column specified as a 5 % phenyl 95 % methyl polysiloxane phase capillary gas chromatographic column

Note 1 to entry: The vapour-fraction of SVOC ranging in volatility to n-C<sub>44</sub> can also be analysed by thermal desorption GC-MS but requires specific sampling and analytical conditions for optimum performance <sup>[22,25]</sup>.

**3.2  
volatile organic compound  
VOC**

organic compound eluting between and including n-hexane and n-hexadecane on a gas chromatographic column specified as a 5 % phenyl 95 % methyl polysiloxane phase capillary gas chromatographic column

**3.3  
very volatile organic compound  
VVOC**

organic compound eluting before n-hexane on a gas chromatographic column specified as 5 % phenyl 95 % methyl polysiloxane phase capillary gas chromatographic column

**3.4  
total volatile organic compounds  
TVOC**

sum of the concentration of the identified and unidentified *volatile organic compounds* (3.2) calculated as detailed in [Annex A](#)

**3.5  
total semi-volatile organic compounds  
TSVOC**

sum of the concentrations of identified and unidentified *semi-volatile organic compounds* (3.1) and calculated as detailed in [Annex A](#)

Note 1 to entry: The limit of volatility of SVOCs included in the TSVOC sum may be defined by the specific task list.

**3.6  
target compound**

individual vapour phase compound in indoor air with a concentration determined quantitatively and reported as a result of this method

**3.7  
task list**

specific list of requirements for sampling and analysis defined prior to testing and reflected in the reporting of the results

Note 1 to entry: The requirements may include a specific target list with or without associated limit criteria, and/or require investigations of unknowns. They may also include particular control of aspects such as the location, duration and frequency of sampling.

**3.8  
laboratory blank**

conditioned sorbent tube from the batch selected for each sampling exercise, retained in the laboratory, sealed with long term storage caps throughout the sampling exercise to be used as a blank tube

Note 1 to entry: These tubes are analysed with the sampled tubes.

**3.9  
field blank**

conditioned sorbent tube from the batch used for the sampling exercise, subjected to the same handling procedure in the field as the sample tubes, including removal and replacement of storage caps, but not used for sample collection

**3.10  
internal standard**

compound of known concentration added to a sample to facilitate the qualitative identification and/or quantitative determination of the sample components



## 4 Abbreviated terms

For the purpose of this document, the following abbreviated terms apply:

FID	flame ionisation detector
GC	gas chromatograph
MS	mass spectrometer
SVOC	semi-volatile organic compounds
TD	thermal desorption
TIC	total ion chromatogram
TSVOC	total semi-volatile organic compounds
TVOC	total volatile organic compounds
VOC	volatile organic compounds
VVOC	very volatile organic compounds

## 5 Principle

A measured volume of sample air is actively collected from indoor air, vehicle interior air, an emission test chamber (see ISO 16000-9, ISO 12219-4, ISO 12219-6) or an emission test cell (see ISO 16000-10) by drawing through one (or more) sorbent tubes. VOC, VVOC and SVOC are retained by the sorbent tube, and the compounds are subsequently analysed in the laboratory to determine the identity, retained mass and associated air concentration of as many individual compounds as required by the specific test. Depending upon the range of target compounds the most appropriate sorbent tube(s), sampling and analytical conditions are applied. The collected compounds are desorbed by heat and transferred under inert carrier gas via a focussing trap into a gas chromatograph equipped with a capillary column and a mass spectrometer, with or without an additional flame ionisation detector (FID).

## 6 Reagents and materials

**6.1 Organic compounds** for calibration of chromatographic quality

**6.2 Dilution solvent** for preparing calibration blend solution for liquid spiking. Shall be of chromatographic quality, free from compounds co-eluting with the compound(s) of interest (6.1)

**6.3 Sorbents**

**6.3.1 General**

Multiple sorbents, suitable for thermal desorption, are commercially available. They range in strength from very retentive sorbents required to retain and release VVOC to very weak sorbents suitable for quantitative sampling and release of SVOC. For particulate sorbents, the relevant particle size is 0,18 mm to 0,60 mm (80 mesh – 30 mesh). For a detailed list of sorbents see [Annex D](#).

**6.3.2 Quartz wool or glass/quartz beads**, clean (i.e. do not produce analytically significant artefacts) and not prone to particle formation.

**6.3.3 Porous Polymers, i.e. Tenax TA<sup>®</sup>** particle size approx. 0,25 mm to approx.0,6 mm (60 mesh to 30 mesh). Tenax TA<sup>®</sup> is a porous polymer based on 2,6-diphenyleneoxide. Manufactured Tenax TA<sup>®</sup> contains quantities of impurities, which shall be removed before using it for air sampling.

**6.3.4 “Carbon black” sorbents**, such as Carbopack X<sup>®2)</sup> or Carbograph 5 TD<sup>®3)</sup>, particle size 0,25 mm to 0,5 mm (60 mesh to 40 mesh). Hydrophobic carbon sorbents suitable for VOC and VVOC with vapour pressures below those typical for C<sub>4</sub> hydrocarbons.

**6.3.5 Carbon molecular sieve (very strong) sorbents** can also be used at the non-sampling end of the tube for trapping VVOC with vapour pressures above those typical for C<sub>4</sub> hydrocarbons. However, note that these sorbents are not completely hydrophobic. Therefore, if such sorbents are included, the tube needs to be dry purged in the sampling direction before analysis.

#### 6.4 Preparing calibration standards on sorbent tubes

As many identified substances as possible, or as required, should be calibrated using original reference compounds. Standards should be introduced to the sampling end of conditioned sorbent tubes using either liquid or gas phase standards.

##### 6.4.1 Gas-phase standards

Standard atmospheres of known concentrations of the compound(s) of interest, shall be prepared by a recognized procedure such as ISO 6141<sup>[1]</sup> or ISO 6145<sup>[2]</sup>. Typical concentrations are around 100 µg/m<sup>3</sup> but levels will vary depending on test requirements. Alternatively, gas standards of appropriate quality and concentration shall be sourced commercially.

If the concentrations in any prepared standard atmosphere are not traceable to primary standards and/or if the inertness and stability of the atmospheres generated cannot be guaranteed, the concentration shall be confirmed using an independent procedure.

NOTE Producing gas phase standards of reactive and/or high boiling compounds can be particularly difficult. Frequent monitoring of the standard is needed.

##### 6.4.2 Loading sorbent tubes with gas-phase standards

Pass a known volume of standard atmosphere or gas standard through a conditioned sorbent tube from the sampling end, e.g. by means of a pump operating at 50 ml/min.

The volume of gas-phase standard sampled shall not exceed the breakthrough volume of sorbent tube for any of the compounds of interest.

After loading disconnect and seal the tube. Prepare fresh standards with each batch of samples. For indoor air and emission test chamber studies, load sorbent tubes with e.g. 100 ml, 200 ml, 400 ml, 1 l, 2 l, 4 l or 10 l of the 100 µg/m<sup>3</sup> standard atmosphere selected.

##### 6.4.3 Calibration blend solution for liquid spiking

Standard solution concentrations will vary depending on test requirements. The selected compound(s) shall be prepared or obtained as a liquid standard in chromatographic-grade solvent (e.g. in methanol) at an appropriate level – typically between 10 ng/µl and 1000 ng/µl – depending on system sensitivity and the analytical conditions selected, for example split ratios. A suitably precise micro-syringe shall

2) Carbopack X<sup>®</sup> is a trade name of Supelco. This information is given for the convenience of users of this document and does not constitute an endorsement by ISO of the product named. Equivalent products may be used if they can be shown to lead to the same results.

3) Carbograph 5 TD<sup>®</sup> is a trade name of Lara. This information is given for the convenience of users of this document and does not constitute an endorsement by ISO of the product named. Equivalent products may be used, if they can be shown to lead the the same results.

be used to introduce 1 µl aliquots of the standard solution onto the sampling end of sorbent tubes in a stream of inert gas as described in 6.4.4. 1 µl is the suggested volume unless solvent can be selectively and efficiently purged without jeopardising breakthrough of the most volatile compound(s) of interest.

The stability and safe storage times of calibration blend solutions shall be determined. Fresh standard solutions shall be prepared accordingly or if there is evidence of deterioration, e.g. reactions between alcohols and ketones.

#### 6.4.4 Loading sorbent tubes with liquid standards

The sampling end of a sorbent tube is fitted to the unheated injection unit of the gas chromatograph (GC) (see 7.6) through which inert purge gas is passed at  $100 \pm 10$  ml/min, and a maximum 1 µl aliquot of an appropriate standard solution is injected through the septum. After 5 min, the tube is disconnected and sealed. Prepare fresh standard tubes with each batch of samples.

NOTE 1 It is more difficult to selectively purge solvent from multi-sorbent tubes, particularly those containing strong sorbents. Smaller injection volumes are recommended for stronger sorbents and multi-sorbent tubes.

Introducing liquid standards onto sorbent tubes via a GC injector is considered the optimum approach to liquid standard introduction, as components reach the sorbent bed in the vapour phase.

Calibration mixtures should be prepared in controlled ambient temperature conditions. Before use, temper the solutions accordingly.

NOTE 2 When preparing standard tubes from liquid standards containing SVOC analytes, efficient transfer is enhanced if the configuration of the injector allows the tip of the syringe to make gentle contact with the sorbent retaining mechanism (e.g. gauze or frit) at the sampling end of the tube.

NOTE 3 It is important to keep liquid standard injection volumes to 1 µl or less unless the solvent can be selectively purged from the tube prior to analysis. Using small injection volumes minimises the difference between standards and samples during analysis thus minimising uncertainty.

NOTE 4 Standard tubes containing VVOC are more typically prepared either from standard atmospheres (see 6.4.1 and 6.4.5) or from concentrated gas standards sourced commercially. It is appropriate for concentrated gas standards to be introduced to the sampling end of sorbent tubes in a stream of carrier gas via an unheated GC injector or similar device.

An internal standard can be added by mixing with the calibration solution or by spiking separately.

NOTE 5 If standard tubes are being prepared by introducing aliquots from more than one standard solution or gas, it is appropriate to first introduce the standard containing higher boiling components and to introduce the most volatile organic compounds last. This minimizes risk of analyte breakthrough during the standard tube loading process.

The purity of the inert carrier gas used to purge sorbent tubes during standard introduction (e.g. He, Ar, N<sub>2</sub>) should permit the detection of an injection of 0,5 ng toluene. The quality of the carrier gas is of great importance, as any contaminants contained in the gas are enriched on the sorbent together with the substances to be analysed.

Other techniques such as direct liquid spiking onto the sorbent bed without gas stream applied are also possible. In this case it is important to use tubes where the syringe needle can directly reach the sorbent bed.

#### 6.4.5 Commercial, pre-loaded standard tubes

Certified pre-loaded standard tubes are available and can be used for establishing analytical quality control and for routine calibration.

## 7 Apparatus

Ordinary laboratory apparatus and in particular the following:

## 7.1 Sorbent tubes of stainless steel or glass,

### 7.1.1 General

Tubes with outside diameter of 6,4 mm (0,25 inch), inside diameter of 5 mm, and of length 89 mm (3,5 inch) fulfil the requirement and are used in many commercial thermal desorbers. Use deactivated glass wool or other suitable mechanism, e.g. stainless-steel frit, to retain the sorbent in the tube. Conditioned and sampled sorbent tubes shall be effectively sealed, e.g. with metal screw caps and combined polytetrafluoroethylene (PTFE) ferrules. Alternative tube dimensions may be applied if appropriate performance data concerning trapping and recovery of target compounds is available as well as information on safe sampling volumes (SSV).

NOTE 1 The unit inch is not allowed in ISO documents; inch equivalents are given for information only.

Pre-packed sorbent tubes are available commercially. Alternatively, sorbent tubes can be filled in the laboratory as follows.

Weigh the appropriate amount of each adsorbent in turn into the tube and tap it down gently to settle, assisted by suction if desired. Place an additional plug or gauze after each sorbent to prevent sorbent mixing and retain the sorbents in the tube.

NOTE 2 The determination of breakthrough volume is specified in ISO 16017-1:2000 Annex B. Breakthrough volumes are used as a measure of sorbent strength (affinity) for organic vapours. They are dependent on temperature and are proportional to the dimensions of the sampling tube and quantity of sorbent. Typically, the SSV is set at 2/3 of the breakthrough volume. As an approximate measure, doubling the bed length while tube diameter is kept constant doubles the breakthrough volume. Similarly, as an approximate measure, a rise of 10 °C in the temperature of the tube during sampling, halves the breakthrough volume. Note that most breakthrough volume and safe volume data (e.g. in [Annex E](#) and in ISO 16017-1:2000) are reported at 20 °C. Note also that the breakthrough volume of some sorbents is adversely affected by high humidity (see ISO 16017-1).

When filling sorbent(s) into tubes, care shall be taken to ensure that the position of the sorbent(s) within the tube corresponds to the position of the tube heater of the instrument used. This ensures direct heating of the sorbent(s), minimising carryover. Contact the instrument manufacturer for details.

### 7.1.2 Sorbent tubes — Combinations and options

See [Annexes C](#) and [D](#) for more information.

Tubes of the dimensions described in [7.1.1](#) may contain up to 3 sorbents as well as quartz (or glass wool), arranged in order, from least retentive to most retentive, from the sampling end. This maximises the target analyte volatility range.

A mass of about 200 mg Tenax TA<sup>®</sup> is suitable for sampling VOC and some higher boiling compounds, e.g. those boiling up to n-C<sub>22</sub>.

NOTE 1 The density of Tenax TA<sup>®</sup> is variable. However, 200 mg of Tenax TA<sup>®</sup> normally occupies ~40 mm depth in a 5 mm bore metal tube and ~60 mm depth in a 4 mm bore glass tube.

The recovery of semi-volatiles (particularly those less volatile than n-C<sub>22</sub>) is facilitated by inserting a short (5 mm to 10 mm) bed of loosely packed quartz wool in front of the 200 ng of Tenax TA<sup>®</sup>.

Quantitative sampling and analysis of VVOC can be achieved by adding a 20 mm bed of a suitable stronger sorbent after the Tenax TA<sup>®</sup>.

NOTE 2 Selection of Carbopack X<sup>®</sup> or Carbograph 5 TD<sup>®</sup> as stronger sorbent facilitates quantitative retention and analysis of compounds as volatile as 1,3-butadiene, but without significant retention of water.

NOTE 3 Alternatively, even stronger sorbents are available (e.g. carbon molecular sieves) which allow ultra-volatile compounds such as C<sub>3</sub> hydrocarbons and vinyl chloride to be trapped. However, tubes packed with such very strong sorbents are prone to some water retention (see ISO 16017-1) and normally require an additional dry purge step prior to TD-GC-MS(FID) analysis.

NOTE 4 Stainless steel or coated stainless steel (metal) tubes of bore 5 mm have capacity for both 200 mg of Tenax TA® and 20 mm of a stronger sorbent.

NOTE 5 A useful example sorbent combination comprises: quartz wool (5 mm); Tenax TA® (175 mg, ~35 mm); and 15–20 mm of Carbograph 5 TD® or Carbo-pack X® - suitable for compounds ranging in volatility from 1,3-butadiene to n-C<sub>30</sub> or more depending on the capability of the thermal desorption instrument selected.

All sorbents shall be held within the central (typically 60 mm) portion of the tube, i.e. the portion that is in direct contact with the tube desorption oven of the apparatus (see [Figure 2](#)).

All sorbent tubes should be desorbed with the flow of carrier gas in the reverse direction to the flow of air during sampling (see [Figure 2](#)).

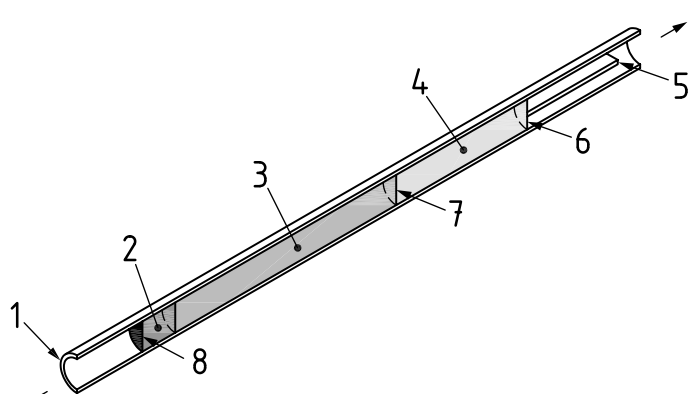

iTeh STANDARD PREVIEW  
(standards.iteh.ai)

#### Key

- 1 stainless steel or coated steel tube
- 2 5 mm quartz wool
- 3 ~35 mm, 175 mg Tenax TA®
- 4 20 mm stronger sorbent, e.g. Carbograph 5 TD® or Carbo-pack X®
- 5 gauze retaining spring
- 6 sorbent retaining gauze
- 7 sorbent retaining gauze or 0,5 mm quartz wool
- 8 sorbent retaining gauze
- a Desorption gas flow.
- b Sampling air flow.

**Figure 2 — Example of a metal tube packed with multiple sorbents for extending the target volatility range from 1,3 butadiene to n-C<sub>30</sub>**

NOTE 6 Optimum pump flow rates for multi-sorbent tubes of the dimensions described are in the range 20 ml/min to 200 ml/min.

NOTE 7 Inert-coated stainless steel or glass tubes are preferred for monitoring reactive, odorous compounds.

Sorbents with significantly different maximum temperatures should not normally be combined in a single tube or it can be difficult to completely condition one without overheating and degrading the other.

An alternative approach is to use tubes containing single sorbents of increasing strength connected together in series using inert unions ([7.2](#)) with the tube containing the weakest sorbent first in line. However, this is an inefficient approach with regard to the resources required for sampling and analysis.

Pre-packed as well as pre-packed and pre-conditioned sorbent tubes are available commercially. Alternatively, sorbent tubes can be filled in the laboratory as specified in [7.1.1](#).