



**SLOVENSKI STANDARD**  
**oSIST prEN ISO 7231:2022**  
**01-september-2022**

---

**Polimerni materiali - Penjeni polimeri - Mehke pene - Določanje vrednosti zračnega pretoka pri konstantni razliki tlakov (ISO/DIS 7231:2022)**

Polymeric materials, cellular, flexible - Determination of air flow value at constant pressure-drop (ISO/DIS 7231:2022)

Weich-elastische Polymerschaumstoffe – Bestimmung der Luftdurchlässigkeit bei konstantem Differenzdruck (ISO/DIS 7231:2022)

Matériaux polymères alvéolaires souples - Détermination de l'indice d'écoulement d'air à chute de pression constante (ISO/DIS 7231:2022)

**Ta slovenski standard je istoveten z: prEN ISO 7231**

---

**ICS:**

83.100          Penjeni polimeri          Cellular materials

**oSIST prEN ISO 7231:2022**          **en,fr,de**



# DRAFT INTERNATIONAL STANDARD

## ISO/DIS 7231

ISO/TC 45/SC 4

Secretariat: DSM

Voting begins on:  
2022-06-21Voting terminates on:  
2022-09-13

---

---

## Polymeric materials, cellular, flexible — Determination of air flow value at constant pressure-drop

*Matériaux polymères alvéolaires souples — Détermination de l'indice d'écoulement d'air à chute de pression constante*

ICS: 83.100

iTeh STANDARD PREVIEW  
(standards.iteh.ai)

[oSIST prEN ISO 7231:2022](https://standards.iteh.ai/catalog/standards/sist/0a1af4fe-8083-4c43-8bd9-8220a2b6fdbf/osist-pren-iso-7231-2022)

<https://standards.iteh.ai/catalog/standards/sist/0a1af4fe-8083-4c43-8bd9-8220a2b6fdbf/osist-pren-iso-7231-2022>

This document is circulated as received from the committee secretariat.

THIS DOCUMENT IS A DRAFT CIRCULATED FOR COMMENT AND APPROVAL. IT IS THEREFORE SUBJECT TO CHANGE AND MAY NOT BE REFERRED TO AS AN INTERNATIONAL STANDARD UNTIL PUBLISHED AS SUCH.

IN ADDITION TO THEIR EVALUATION AS BEING ACCEPTABLE FOR INDUSTRIAL, TECHNOLOGICAL, COMMERCIAL AND USER PURPOSES, DRAFT INTERNATIONAL STANDARDS MAY ON OCCASION HAVE TO BE CONSIDERED IN THE LIGHT OF THEIR POTENTIAL TO BECOME STANDARDS TO WHICH REFERENCE MAY BE MADE IN NATIONAL REGULATIONS.

RECIPIENTS OF THIS DRAFT ARE INVITED TO SUBMIT, WITH THEIR COMMENTS, NOTIFICATION OF ANY RELEVANT PATENT RIGHTS OF WHICH THEY ARE AWARE AND TO PROVIDE SUPPORTING DOCUMENTATION.

**ISO/CEN PARALLEL PROCESSING**



Reference number  
ISO/DIS 7231:2022(E)

© ISO 2022

# iTeh STANDARD PREVIEW (standards.iteh.ai)

[oSIST prEN ISO 7231:2022](https://standards.iteh.ai/catalog/standards/sist/0a1af4fe-8083-4c43-8bd9-8220a2b6fdbf/osist-pren-iso-7231-2022)

<https://standards.iteh.ai/catalog/standards/sist/0a1af4fe-8083-4c43-8bd9-8220a2b6fdbf/osist-pren-iso-7231-2022>



## **COPYRIGHT PROTECTED DOCUMENT**

© ISO 2022

All rights reserved. Unless otherwise specified, or required in the context of its implementation, no part of this publication may be reproduced or utilized otherwise in any form or by any means, electronic or mechanical, including photocopying, or posting on the internet or an intranet, without prior written permission. Permission can be requested from either ISO at the address below or ISO's member body in the country of the requester.

ISO copyright office  
CP 401 • Ch. de Blandonnet 8  
CH-1214 Vernier, Geneva  
Phone: +41 22 749 01 11  
Email: [copyright@iso.org](mailto:copyright@iso.org)  
Website: [www.iso.org](http://www.iso.org)

Published in Switzerland

# Contents

	Page
<b>Foreword</b> .....	<b>iv</b>
<b>1 Scope</b> .....	<b>1</b>
<b>2 Normative references</b> .....	<b>1</b>
<b>3 Terms and definitions</b> .....	<b>1</b>
<b>4 Principle</b> .....	<b>1</b>
<b>5 Method A</b> .....	<b>2</b>
5.1 Apparatus.....	2
5.1.1 General.....	2
5.1.2 Flow meters.....	2
5.1.3 Manometer.....	2
5.1.4 Air supply or suction equipment.....	2
5.1.5 Test piece mounting.....	2
5.1.6 Vacuum chamber operated at below atmosphere pressure.....	2
5.2 Test pieces.....	3
5.3 Test conditions.....	3
5.4 Procedure.....	3
5.5 Test report.....	3
<b>6 Method B</b> .....	<b>5</b>
6.1 Method B1 with manual measurement.....	5
6.1.1 Apparatus.....	5
6.1.2 Test pieces.....	6
6.1.3 Test conditions.....	6
6.1.4 Procedure.....	6
6.1.5 Precision.....	9
6.1.6 Test report.....	9
6.2 Method B2 with automatic measurement.....	9
6.2.1 Apparatus.....	9
6.2.2 Test pieces.....	11
6.2.3 Test conditions.....	11
6.2.4 Procedure.....	12
6.2.5 Test report.....	12
<b>Annex A (informative) Precision of Method B1</b> .....	<b>13</b>
<b>Bibliography</b> .....	<b>15</b>

## ISO/DIS 7231:2022(E)

### Foreword

ISO (the International Organization for Standardization) is a worldwide federation of national standards bodies (ISO member bodies). The work of preparing International Standards is normally carried out through ISO technical committees. Each member body interested in a subject for which a technical committee has been established has the right to be represented on that committee. International organizations, governmental and non-governmental, in liaison with ISO, also take part in the work. ISO collaborates closely with the International Electrotechnical Commission (IEC) on all matters of electrotechnical standardization.

The procedures used to develop this document and those intended for its further maintenance are described in the ISO/IEC Directives, Part 1. In particular, the different approval criteria needed for the different types of ISO documents should be noted. This document was drafted in accordance with the editorial rules of the ISO/IEC Directives, Part 2 (see [www.iso.org/directives](http://www.iso.org/directives)).

Attention is drawn to the possibility that some of the elements of this document may be the subject of patent rights. ISO shall not be held responsible for identifying any or all such patent rights. Details of any patent rights identified during the development of the document will be in the Introduction and/or on the ISO list of patent declarations received (see [www.iso.org/patents](http://www.iso.org/patents)).

Any trade name used in this document is information given for the convenience of users and does not constitute an endorsement.

For an explanation of the voluntary nature of standards, the meaning of ISO specific terms and expressions related to conformity assessment, as well as information about ISO's adherence to the World Trade Organization (WTO) principles in the Technical Barriers to Trade (TBT), see [www.iso.org/iso/foreword.html](http://www.iso.org/iso/foreword.html).

This document was prepared by Technical Committee ISO/TC45, *Rubber and rubber products*, Subcommittee SC 4, *Products (other than hoses)*.

This third edition cancels and replaces the second edition (ISO 7231:2010), which has been technically revised.

The main changes compared to the previous edition are as follows:

- [Annex A](#) has been included into the body text as method B2.
- Subclause 6.5, the precision of method B1 has been moved to [Annex A](#) as informative.

Any feedback or questions on this document should be directed to the user's national standards body. A complete listing of these bodies can be found at [www.iso.org/members.html](http://www.iso.org/members.html).

# Polymeric materials, cellular, flexible — Determination of air flow value at constant pressure-drop

**WARNING** — Persons using this document should be familiar with normal laboratory practice. This document does not purport to address all of the safety problems, if any, associated with its use. It is the responsibility of the user to establish appropriate safety and health practices and to ensure compliance with any national regulatory conditions.

## 1 Scope

This document specifies two methods for determining the air flow value of flexible cellular polymeric materials:

- method A, for conventional types of flexible cellular polymeric material;
- method B, for all types of flexible cellular polymeric material, but especially for materials with a low permeability to air.

For method B two methods are specified in this document:

- Method B1: with manual measurement
- Method B2: with automatic measurement

NOTE 1 Air flow values can be used to give an indication of the effects of formulation and production variables on the cellular structure.

NOTE 2 In this document, the expression “conventional type of flexible cellular polymeric material” means types which are unsuitable for sealing purposes.

## 2 Normative references

There are no normative references in this document.

## 3 Terms and definitions

For the purposes of this document, the following terms and definitions apply.

ISO and IEC maintain terminological databases for use in standardization at the following addresses:

- ISO Online browsing platform: available at <https://www.iso.org/obp>
- IEC Electropedia: available at <https://www.electropedia.org/>

### 3.1

#### air flow value

volume flow rate required to maintain a constant pressure differential across a flexible foam test piece.

## 4 Principle

A specified constant air pressure differential is created across a standard flexible foam specimen. The rate of flow of air required to maintain this pressure differential is measured as the air flow value.

## ISO/DIS 7231:2022(E)

### 5 Method A

#### 5.1 Apparatus

##### 5.1.1 General

Diagrams of suitable apparatus are shown in [Figure 1](#) (using an air pressure below atmospheric) and [Figure 2](#) (using an air pressure above atmospheric). The essential parts are described in [5.1.2](#) to [5.1.5](#).

##### 5.1.2 Flow meters

Low-pressure-drop flow meters with an accuracy of up to  $\pm 2\%$  are required for air flow measurements. The actual air flow shall be adjusted by a combination of valve restriction, as shown in [Figures 1](#) and [2](#), and blower or vacuum pump speed, so that the required pressure difference across the specimen [see [5.4 c\)](#)] is maintained constant.

Air flow meters with at least 250 mm scales are recommended. Flow-meters measuring in the range  $0 \text{ dm}^3/\text{s}$  to  $10 \text{ dm}^3/\text{s}$  will cover a wide variety of cellular polymeric materials.

##### 5.1.3 Manometer

A manometer graduated in the 0 Pa to 250 Pa range and with an accuracy of  $\pm 2\%$  is required. Traps to prevent manometer fluid being drawn into the test chamber by accidental pressure changes shall be provided. A plunger in the fluid reservoir is used to set the zero point after levelling the manometer.

The use of an inclined manometer with 2 Pa graduations is recommended. A level mounted on the manometer should be used to ensure that the proper degree of inclination from the horizontal is maintained.

##### 5.1.4 Air supply or suction equipment

The air supply or suction may be such that positive or negative pressure differences from atmospheric pressure are obtained across the test piece, using compressed air, an exhaust blower or a vacuum pump, etc.

NOTE A particular apparatus can be constructed to use only positive or negative pressure.

##### 5.1.5 Test piece mounting

A chamber of nominal dimensions 140 mm diameter  $\times$  150 mm depth (see [Figure 1](#)) or 75 mm diameter  $\times$  1 000 mm length (see [Figure 2](#)), incorporating a test piece mounting and fittings for the manometer and exhaust, shall be provided. The test piece cavity shall be  $(50 \pm 0,05) \text{ mm} \times (50 \pm 0,05) \text{ mm} \times (25 \pm 0,05) \text{ mm}$ .

The test piece shall be supported by suitable means, for example by the use of vanes, wires or a perforated support. The support shall provide a minimum open proportion of 70 % of the overall area, evenly distributed over its area (see [Figures 1](#) and [2](#) for the positioning of the supports). Manometer and exhaust fittings shall be as shown in [Figures 1](#) and [2](#).

##### 5.1.6 Vacuum chamber operated at below atmosphere pressure

The apparatus, shown in [Figure 1](#), shall be checked for leaks in the following manner:

- a) Seal the test piece mounting cavity with masking tape.
- b) With all the flow-meter valves closed, turn the air supply to approximately one-third of the maximum setting and observe any movement of the manometer. The manometer reading shall not exceed 1 Pa after 30 s.



- c) Open the valve on the lowest-range flow-meter very slightly. The flow shall be essentially zero, as shown by a movement of less than 3 mm of the flow-meter float from its static position.

## 5.2 Test pieces

The test pieces shall normally be in the form of a right parallelepiped of dimensions  $(51,0 \pm 0,3)$  mm  $\times$   $(51,0 \pm 0,3)$  mm  $\times$   $(25,0 \pm 0,3)$  mm. If test pieces of a different thickness are used, the thickness shall be stated in the test report. Any test pieces with length or breadth dimensions outside the required tolerance shall be discarded as they will lead to inaccurate air flow values. The test pieces shall be cut out without deformation of the original cell structure. Three test pieces shall be tested.

NOTE Test pieces both with and without surface skin can be tested by this method, but the results will not be comparable.

## 5.3 Test conditions

Testing shall be carried out under the standard conditions of either  $(23 \pm 2)$  °C and  $(50 \pm 5)$  % relative humidity or  $(27 \pm 2)$  °C and  $(65 \pm 5)$  % relative humidity, unless otherwise specified.

NOTE Since the flow-meter calibration is sensitive to temperature, the results obtained with these two sets of conditions will not necessarily be comparable

## 5.4 Procedure

The method of measurement shall be as follows:

- a) Place the test piece in the test cavity with any skin on the side exposed to the lower pressure. Make sure that the test piece is free from undue strain and that a good air seal is obtained between the edges of the test piece and the apparatus.
- b) Close the flow-meter valves and switch on the blower or vacuum pump.
- c) Open the high-range flow-meter slowly and adjust the air flow to obtain a pressure differential of  $(125 \pm 1)$  Pa on the manometer.
- d) If this reading is less than 10 % of full scale, close the valve of this flow-meter and open the medium-range flow-meter valve. Repeat this procedure until the correct flow-meter has been selected and the reading obtained.

For greater accuracy, it is preferable to use two adjacent flow-meters, holding the higher-range one steady on an appropriate graduation mark and making the adjustment on the lower-range one. In this case, the air flow value is obtained from the sum of the two flow-meter readings after maintaining the pressure differential for 10 s.

- e) Record the reading obtained as described in step d), in cubic decimetres per second, as the air flow value for the specimen.

NOTE Calibration of the apparatus can be carried out using a plate of known flow-rate value which is usually supplied by the manufacturer.

## 5.5 Test report

The test report shall include the following information:

- a) a reference to this document including its year of publication, i.e. ISO 7231;xxxx(year) ;
- b) the method used (method A);
- c) all details necessary to identify the material tested;
- d) the individual test results and the mean air flow value( $\text{dm}^3/\text{s}$ );

## ISO/DIS 7231:2022(E)

- e) if test pieces of thickness different from that specified in 5.2 were used, the thickness of the test pieces;
- f) the orientation of the test pieces with respect to the direction of any anisotropy and the presence or absence of any skins;
- g) the test conditions used, i.e. temperature, relative humidity, apparatus type and pressure direction;
- h) the date of the test.

Dimensions in millimeters

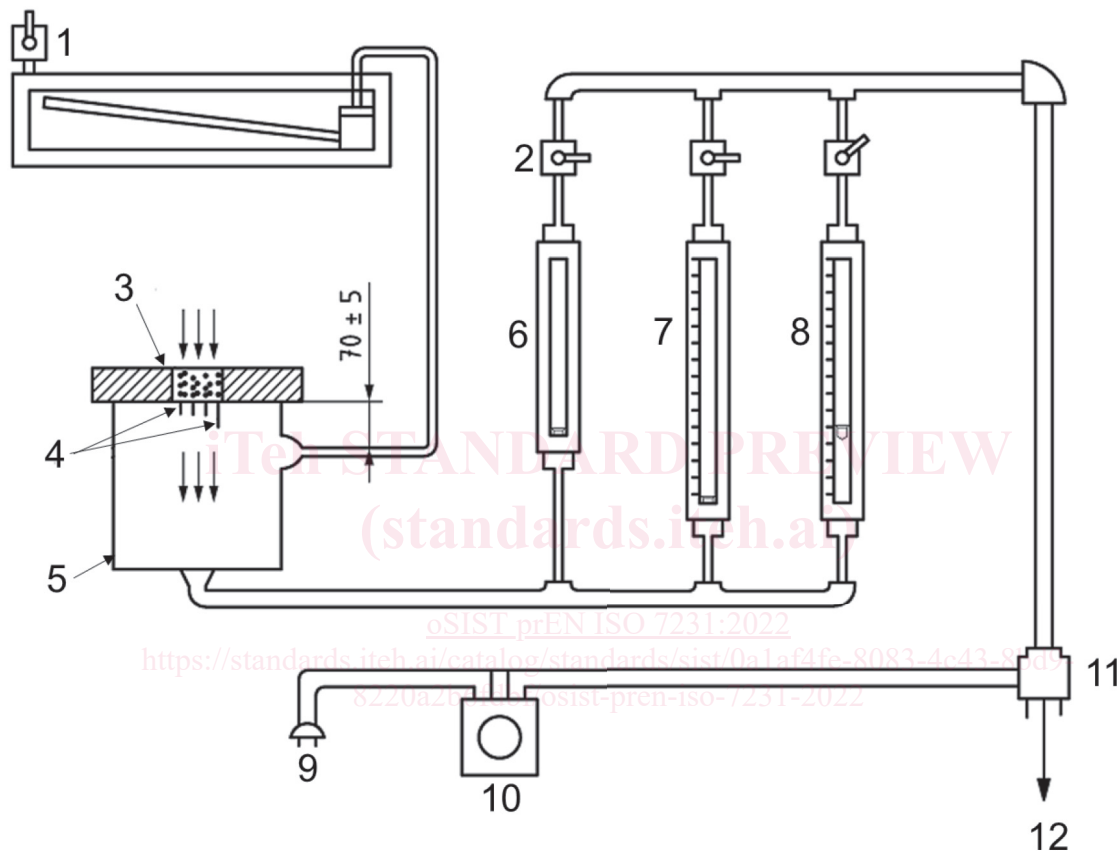

## Key

- 1 inclined oil manometer
- 2 two-way ball valve
- 3 test piece
- 4 test piece support vanes
- 5 vacuum chamber
- 6 low-range air flow-meter
- 7 medium-range air flow-meter
- 8 high-range air flow-meter
- 9 power supply
- 10 voltage control
- 11 vacuum pump
- 12 exhaust

**Figure 1 — Method A: Air flow apparatus (using air pressure below atmospheric)**

Dimensions in millimeters

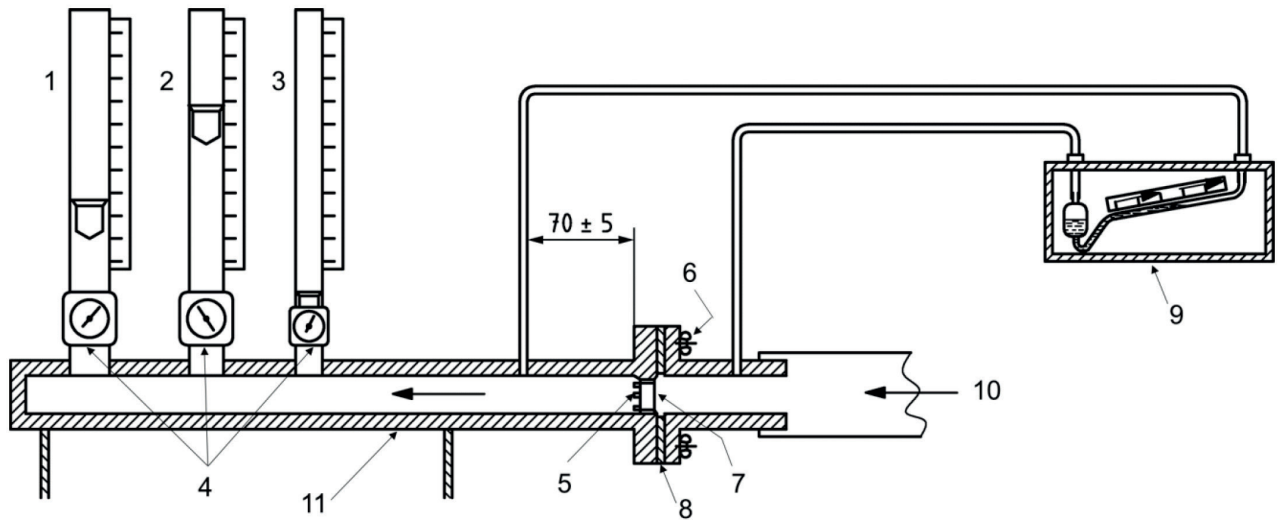
**Key**

- 1 high-range air flow-meter
- 2 medium-range air flow-meter
- 3 low-range air flow-meter
- 4 valves
- 5 horizontal steel rods to retain test piece in position
- 6 wing nut
- 7 test piece
- 8 gasket
- 9 inclined manometer
- 10 air supply
- 11 test chamber

**Figure 2 — Method A: Air flow apparatus (using air pressure above atmospheric)**

## 6 Method B

### 6.1 Method B1 with manual measurement

#### 6.1.1 Apparatus

##### 6.1.1.1 General

An example of the manual test apparatus is shown in [Figure 3](#). The essential parts of the apparatus are as described in [6.1.1.2](#) to [6.1.1.5](#).

##### 6.1.1.2 Air orifice

A metal plate with an orifice of a suitable size shall be mounted in the partition in the cylindrical test chamber. Generally, 10 such plates with different sizes of orifice are available, and one of them is chosen according to the air flow value of the test piece.