

---

---

**Agricultural vehicles — Mechanical  
connections between towed and  
towing vehicles —**

**Part 3:  
Tractor drawbar**

**iTeh STANDARD PREVIEW**  
*Véhicules agricoles — Liaisons mécaniques entre véhicules  
remorqueurs et véhicules remorqués —  
(standards.iteh.ai)  
Partie 3: Barre d'attelage du tracteur*

[ISO 6489-3:2021](https://standards.iteh.ai/catalog/standards/sist/3c5409a3-89a5-4fa1-89ea-14a5fbb1d0f0/iso-6489-3-2021)

<https://standards.iteh.ai/catalog/standards/sist/3c5409a3-89a5-4fa1-89ea-14a5fbb1d0f0/iso-6489-3-2021>



**iTeh STANDARD PREVIEW**  
**(standards.iteh.ai)**

[ISO 6489-3:2021](https://standards.iteh.ai/catalog/standards/sist/3c5409a3-89a5-4fa1-89ea-14a5fbb1d0f0/iso-6489-3-2021)

<https://standards.iteh.ai/catalog/standards/sist/3c5409a3-89a5-4fa1-89ea-14a5fbb1d0f0/iso-6489-3-2021>



**COPYRIGHT PROTECTED DOCUMENT**

© ISO 2021

All rights reserved. Unless otherwise specified, or required in the context of its implementation, no part of this publication may be reproduced or utilized otherwise in any form or by any means, electronic or mechanical, including photocopying, or posting on the internet or an intranet, without prior written permission. Permission can be requested from either ISO at the address below or ISO's member body in the country of the requester.

ISO copyright office  
CP 401 • Ch. de Blandonnet 8  
CH-1214 Vernier, Geneva  
Phone: +41 22 749 01 11  
Email: [copyright@iso.org](mailto:copyright@iso.org)  
Website: [www.iso.org](http://www.iso.org)

Published in Switzerland

# Contents

	Page
Foreword .....	iv
<b>1 Scope</b> .....	<b>1</b>
<b>2 Normative references</b> .....	<b>1</b>
<b>3 Terms and definitions</b> .....	<b>1</b>
<b>4 Specifications</b> .....	<b>2</b>
4.1 Drawbar clevis .....	2
4.2 Drawbar hitch point .....	2
4.3 Drawbar categories .....	2
4.4 Drawbar location and position .....	3
4.5 Drawbar dimensions .....	4
<b>5 Vertical drawbar load</b> .....	<b>7</b>
<b>6 PTO drive shaft clearance</b> .....	<b>7</b>
<b>7 Marking</b> .....	<b>8</b>
<b>Bibliography</b> .....	<b>9</b>

## iTeh STANDARD PREVIEW (standards.iteh.ai)

[ISO 6489-3:2021](https://standards.iteh.ai/catalog/standards/sist/3c5409a3-89a5-4fa1-89ea-14a5fbb1d0f0/iso-6489-3-2021)

<https://standards.iteh.ai/catalog/standards/sist/3c5409a3-89a5-4fa1-89ea-14a5fbb1d0f0/iso-6489-3-2021>

## Foreword

ISO (the International Organization for Standardization) is a worldwide federation of national standards bodies (ISO member bodies). The work of preparing International Standards is normally carried out through ISO technical committees. Each member body interested in a subject for which a technical committee has been established has the right to be represented on that committee. International organizations, governmental and non-governmental, in liaison with ISO, also take part in the work. ISO collaborates closely with the International Electrotechnical Commission (IEC) on all matters of electrotechnical standardization.

The procedures used to develop this document and those intended for its further maintenance are described in the ISO/IEC Directives, Part 1. In particular, the different approval criteria needed for the different types of ISO documents should be noted. This document was drafted in accordance with the editorial rules of the ISO/IEC Directives, Part 2 (see [www.iso.org/directives](http://www.iso.org/directives)).

Attention is drawn to the possibility that some of the elements of this document may be the subject of patent rights. ISO shall not be held responsible for identifying any or all such patent rights. Details of any patent rights identified during the development of the document will be in the Introduction and/or on the ISO list of patent declarations received (see [www.iso.org/patents](http://www.iso.org/patents)).

Any trade name used in this document is information given for the convenience of users and does not constitute an endorsement.

For an explanation of the voluntary nature of standards, the meaning of ISO specific terms and expressions related to conformity assessment, as well as information about ISO's adherence to the World Trade Organization (WTO) principles in the Technical Barriers to Trade (TBT), see [www.iso.org/iso/foreword.html](http://www.iso.org/iso/foreword.html).

This document was prepared by Technical Committee ISO/TC 23, *Tractors and machinery for agriculture and forestry*, Subcommittee SC 4, *Tractors*. <https://standards.iteh.ai/catalog/standards/sist/3c5409a3-89a5-4fa1-89ea-3d05fd1e1d1c/iso-6489-3-2021>

This third edition cancels and replaces the second edition (ISO 6489-3:2004), which has been technically revised.

The main changes compared to the previous edition are as follows:

- addition of specifications for drawbar position dimension  $T$  for PTO type 4;
- addition of a new dimension  $L$  (distance from hitch pin hole to the tyre OD for wheeled tractors or for tracked tractors to the rear most vertical tangent line with the tracks at their rearmost pivoted position);
- specification of pin diameter as a range;
- addition of requirements for marking.

A list of all parts in the ISO 6489 series can be found on the ISO website.

Any feedback or questions on this document should be directed to the user's national standards body. A complete listing of these bodies can be found at [www.iso.org/members.html](http://www.iso.org/members.html).

# Agricultural vehicles — Mechanical connections between towed and towing vehicles —

## Part 3: Tractor drawbar

### 1 Scope

This document specifies the dimensional requirements and location for category 0, 1, 2, 3, 4 and 5 drawbars mounted on the rear of agricultural tractors.

### 2 Normative references

The following documents are referred to in the text in such a way that some or all of their content constitutes requirements of this document. For dated references, only the edition cited applies. For undated references, the latest edition of the referenced document (including any amendments) applies.

ISO 789-1, *Agricultural tractors — Test procedures — Part 1: Power tests for power take-off*

ISO 5673-2, *Agricultural tractors and machinery — Power take-off drive shafts and power-input connection — Part 2: Specification for use of PTO drive shafts, and position and clearance of PTO drive line and PIC for various attachments*

ISO 14396, *Reciprocating internal combustion engines — Determination and method for the measurement of engine power — Additional requirements for exhaust emission tests in accordance with ISO 8178*

### 3 Terms and definitions

For the purposes of this document, the following terms and definitions apply.

ISO and IEC maintain terminological databases for use in standardization at the following addresses:

- ISO Online browsing platform: available at <https://www.iso.org/obp>
- IEC Electropedia: available at <http://www.electropedia.org/>

#### 3.1 tractor drawbar drawbar

mechanical connection mounted on the rear of an agricultural tractor for the mechanical coupling of an implement

Note 1 to entry: A tractor drawbar can be non-adjustable or adjustable.

#### 3.1.1 non-adjustable drawbar

fixed drawbar with no possibility for adjustment

#### 3.1.2 adjustable drawbar

adjustable, multiple operating position drawbar providing the regular, short and extended drawbar positions

3.1.3

**regular drawbar position**

position of the *adjustable drawbar* (3.1.2) and *non-adjustable drawbar* (3.1.1) providing the standard dimension from drawbar pin hole to end of PTO for the type of PTO on the tractor

3.1.4

**short drawbar position**

position of the adjustable drawbar intended to connect non-PTO driven equipment that applies a high vertical load to the drawbar

3.1.5

**extended drawbar position**

position of the adjustable drawbar intended for a special PTO drive shaft condition where equal angularity of the drive shaft joints cannot be obtained using the *regular drawbar position* (3.1.3)

3.2

**PTO drive shaft clearance plane**

imaginary plane which establishes the upper permissible limit of protrusion of the drawbar and clevis

3.3

**drawbar hitch point**

connection point between *tractor drawbar* (3.1) and implement end

4 Specifications

iTeh STANDARD PREVIEW  
(standards.iteh.ai)

4.1 Drawbar clevis

The drawbar clevis shall be removable to allow installation of special attachments or connection to implements which have a clevis end (see Figure 6). It may also be necessary to remove the clevis to provide PTO driveshaft clearance with implements which do not meet the dimensions specified in ISO 5673-2.

4.2 Drawbar hitch point

Provisions shall be made on the tractor for the connection of the tractor drawbar to the implement, in a position with the drawbar hitch point directly in line with the longitudinal centreline of the tractor PTO.

4.3 Drawbar categories

See Table 1.

Table 1 — Drawbar categories

Values in kilowatts

Drawbar category	PTO power <sup>a</sup> at rated engine speed
0	≤ 28
1	≤ 48
2	≤ 115
3	≤ 185
4	≤ 300
5	≤ 500

<sup>a</sup> Shall be determined in accordance with ISO 789-1 or OECD code 1 or 2. If PTO power is not available, use 86 % of engine power in accordance with ISO 14396

**4.4 Drawbar location and position**

The drawbar location and position shall conform to [Figure 1](#) and [Tables 2](#) and [3](#).

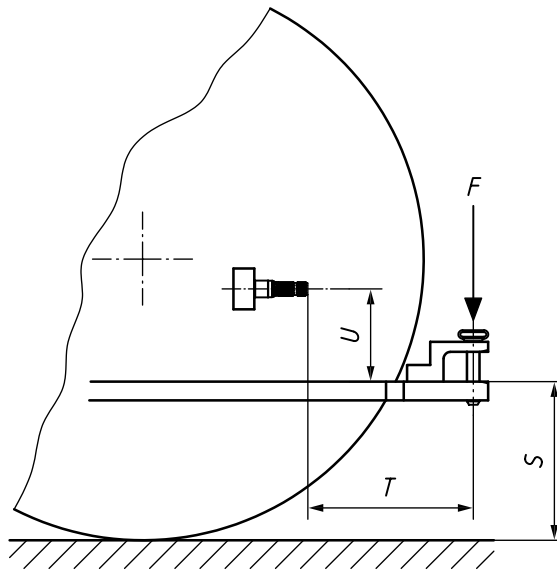

**Key**

*F* vertical load

NOTE [Tables 2](#) and [3](#) explain the symbols and give the dimension values.

iTech STANDARD PREVIEW  
(standards.iteh.ai)

**Figure 1 — Drawbar location and position**

ISO 6489-3:2021

<https://standards.iteh.ai/catalog/standards/sist/3c5409a3-89a5-4fa1-89ea-14a51661d010/iso-6489-3-2021>  
**Table 2 — Drawbar location — Values of the dimension *S* and *U***

Dimensions in millimetres

Dimension	Drawbar category					
	0	1	2	3	4	5
Height of drawbar <sup>a</sup> , <i>S</i>	220 to 420	330 to 500	330 to 500	380 to 560	380 to 560	400 to 600
<i>U</i> min.	200	220	250	260	280	310

<sup>a</sup> The *S* dimension should be met for normal agricultural applications. On tractors especially designed for high ground clearance, such as working in standing vegetable crops or sugar cane, *S* may exceed the maximum. On tractors designed for low ground clearance, such as lawn mowing or ground care, which require a low centre of gravity, *S* may be less than the minimum.

**Table 3 — Drawbar position — Values of the dimension *T***

Dimensions in millimetres

PTO type <sup>a</sup>	<i>T</i> ± 10		
	Short drawbar position <sup>b</sup>	Regular drawbar position	Extended drawbar position
1 and 2	250	400 <sup>b</sup>	550
3 and 4	350	500	650

<sup>a</sup> See ISO 500-1 for identification of PTO types.

<sup>b</sup> A 350 mm position may be provided to accommodate 540 r/min PTO implements which are not compliant with ISO 5673-2.

Longitudinal distance, *L*, should be 25 mm minimum for all drawbar categories. For wheeled tractors, this distance is from the centre of the hitch pin hole to the tire OD as shown in [Figure 2](#). For tracked tractors, this distance is from the centre of the hitch pin hole to the rear most vertical tangent line with the tracks at their rearmost pivoted position, as shown in [Figure 3](#).

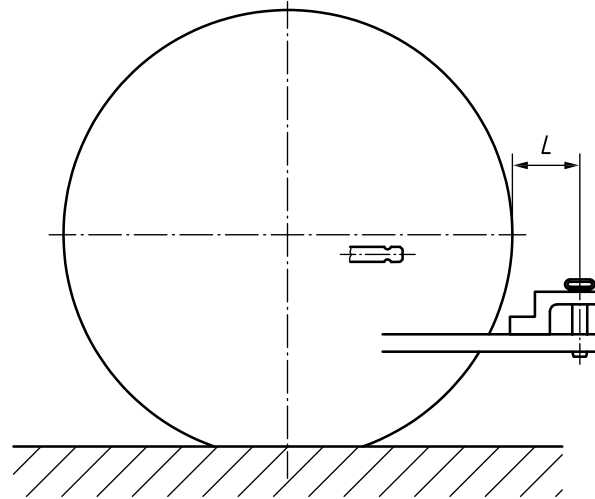

Figure 2 — Location of dimension  $L$  — Wheeled tractors

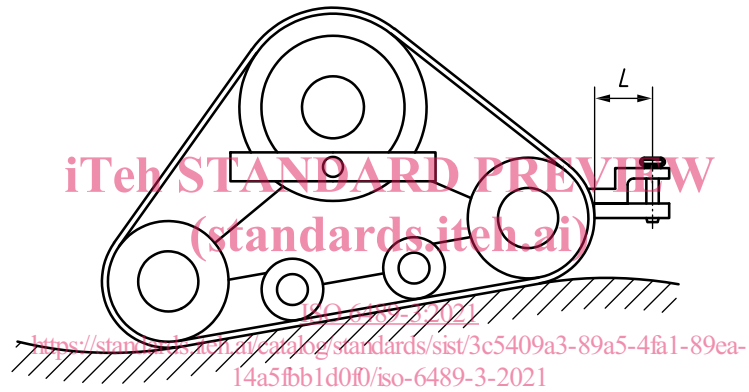

Figure 3 — Location of dimension  $L$  — Tracked tractors

Dimension  $L$  does not apply to short drawbar positions where PTO's are not used.

Dimension  $L$  applies with drawbar centred laterally.

Use maximum grown tire diameter for largest R1/R1W tires that will be specified for tractor.

#### 4.5 Drawbar dimensions

The drawbar dimensions shall conform to [Figure 4](#) and [Table 4](#).



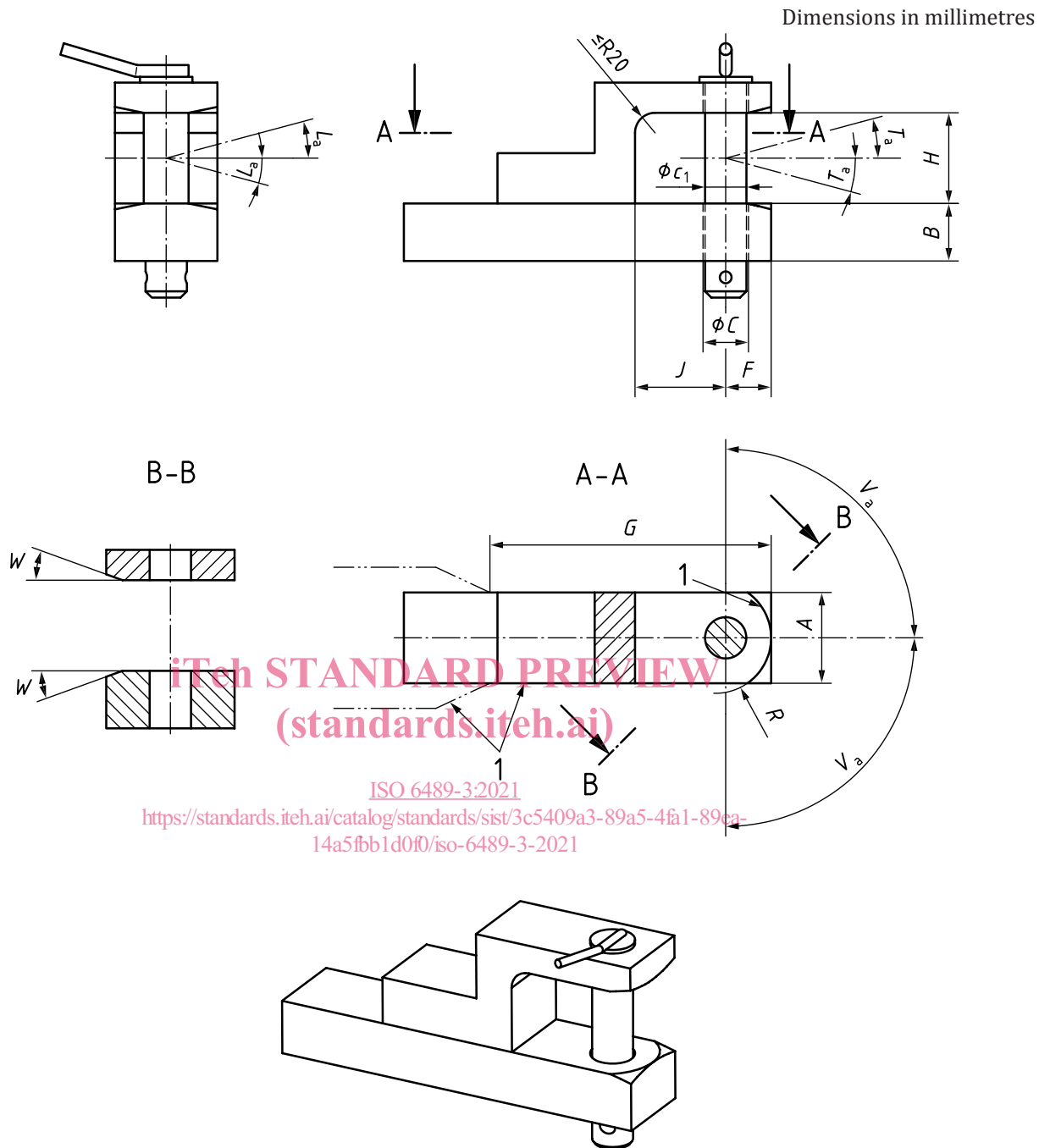

**Key**

$L_a$  angle of roll

$T_a$  angle of pitch

$V_a$  angle of yaw

1 optional shape

a Distance over which the maximum value of dimensions A and B shall be maintained.

NOTE See [Clause 6](#) for explanation and recommendations for adequate articulation between tractor and implement.

**Figure 4 — Tractor drawbar and clevis**

**Table 4 — Tractor drawbar and clevis — Dimension values**

Dimensions in millimetres

Dimension		Drawbar category					
		0	1	2	3	4	5
Drawbar width, $A^a$	max.	60	67	90	90	130	160
Drawbar thickness, $B$	max.	20	36	52	57	64	80
Pin hole diameter, $C$	+0,80 -0,25	20	33	33	41	52,5	72,5
Pin diameter, $C1$	range	18 to 19	30 to 31,4	30 to 31,4	38 to 39,4	50 to 51,2	70 to 71,2
$F$	max.	30	40	45	45	65	80
$G^b$	min.	140	210	210	210	210	210
Height, $H$	min.	50	70	70	90	90	100
Throat depth, $J$	min.	50	70	80	80	90	110
End radius of drawbar and clevis, $R^c$	max.	35	40	55	55	80	95
$W^c$	min	20°	20°	20°	20°	15°	15°

<sup>a</sup> The drawbar pin handle, retention devices, or clevis may extend beyond width  $A$ , but must not interfere with the implement articulation angles specified in [Clause 6](#).

<sup>b</sup>  $G$  is the distance over which the specified dimensions  $A$  and  $B$  shall be maintained.

<sup>c</sup> The profile shown in [Figure 4](#) represents the maximum envelope for the drawbar and clevis. The radius  $R$  and angle  $W$  may differ from the values given so long as the maximum envelope is not exceeded. Any shape which provides the maximum envelope is acceptable.

ITIH STANDARD PREVIEW  
(standards.iteh.ai)

An auxiliary hole may be provided in addition. This auxiliary hole, as defined in [Table 5](#) and [Figure 5](#), is used for other hitching applications which require the clevis to be removed from the tractor drawbar. The additional hole allows for installation of special attachments or connecting to implements that have a clevis.

**Table 5 — Tractor drawbar auxiliary hole dimensions**

Dimensions in millimetres

Dimension	Drawbar category					
	0	1	2	3	4	5
Auxiliary hole diameter, $D$	NA	21 <sup>+0,8</sup>	21 <sup>+0,8</sup>	23,5 <sup>+0,8</sup> <sub>-3,3</sub>	NA	NA
Distance, $E$	NA	102 <sup>±0,8</sup>	102 <sup>±0,8</sup>	102 <sup>±0,8</sup>	NA	NA

NA Not applicable