

---

---

**Robotics — Performance criteria  
and related test methods for service  
robots —**

**Part 3:  
Manipulation**

**iTeh STANDARD PREVIEW**  
*Robotique — Critères de performance et méthodes d'essai  
correspondantes pour robots de service —  
Partie 3: Manipulation*  
(standards.iteh.ai)

ISO 18646-3:2021

<https://standards.iteh.ai/catalog/standards/sist/65c77530-8331-4c1a-808c-1621001e0646/iso-18646-3-2021>



**iTeh STANDARD PREVIEW**  
**(standards.iteh.ai)**

ISO 18646-3:2021

<https://standards.iteh.ai/catalog/standards/sist/65c77530-8331-4c1a-808c-1621001e0646/iso-18646-3-2021>



**COPYRIGHT PROTECTED DOCUMENT**

© ISO 2021

All rights reserved. Unless otherwise specified, or required in the context of its implementation, no part of this publication may be reproduced or utilized otherwise in any form or by any means, electronic or mechanical, including photocopying, or posting on the internet or an intranet, without prior written permission. Permission can be requested from either ISO at the address below or ISO's member body in the country of the requester.

ISO copyright office  
CP 401 • Ch. de Blandonnet 8  
CH-1214 Vernier, Geneva  
Phone: +41 22 749 01 11  
Email: [copyright@iso.org](mailto:copyright@iso.org)  
Website: [www.iso.org](http://www.iso.org)

Published in Switzerland

# Contents

	Page
<b>Foreword</b> .....	<b>iv</b>
<b>Introduction</b> .....	<b>v</b>
<b>1 Scope</b> .....	<b>1</b>
<b>2 Normative references</b> .....	<b>1</b>
<b>3 Terms and definitions</b> .....	<b>1</b>
<b>4 Test conditions</b> .....	<b>3</b>
4.1 General.....	3
4.2 Operational mode.....	3
4.3 Test configuration and trial.....	4
<b>5 Grasping characteristics</b> .....	<b>4</b>
5.1 General.....	4
5.2 Grasp size.....	4
5.2.1 Purpose.....	4
5.2.2 Test facility.....	4
5.2.3 Test procedure.....	5
5.2.4 Test result.....	6
5.3 Grasp strength.....	6
5.3.1 Purpose.....	6
5.3.2 Test facility.....	6
5.3.3 Test procedure.....	7
5.3.4 Test result.....	8
5.4 Grasp slip resistance.....	8
5.4.1 Purpose.....	8
5.4.2 Test facility.....	8
5.4.3 Test procedure.....	9
5.4.4 Test result.....	9
<b>6 Use cases</b> .....	<b>10</b>
6.1 General.....	10
6.2 Opening a hinged door.....	10
6.2.1 Purpose.....	10
6.2.2 Test facility.....	10
6.2.3 Test procedure.....	11
6.2.4 Test result.....	11
6.3 Opening a sliding door.....	11
6.3.1 Purpose.....	11
6.3.2 Test facility.....	11
6.3.3 Test procedure.....	12
6.3.4 Test result.....	12
<b>Bibliography</b> .....	<b>14</b>

## Foreword

ISO (the International Organization for Standardization) is a worldwide federation of national standards bodies (ISO member bodies). The work of preparing International Standards is normally carried out through ISO technical committees. Each member body interested in a subject for which a technical committee has been established has the right to be represented on that committee. International organizations, governmental and non-governmental, in liaison with ISO, also take part in the work. ISO collaborates closely with the International Electrotechnical Commission (IEC) on all matters of electrotechnical standardization.

The procedures used to develop this document and those intended for its further maintenance are described in the ISO/IEC Directives, Part 1. In particular, the different approval criteria needed for the different types of ISO documents should be noted. This document was drafted in accordance with the editorial rules of the ISO/IEC Directives, Part 2 (see [www.iso.org/directives](http://www.iso.org/directives)).

Attention is drawn to the possibility that some of the elements of this document may be the subject of patent rights. ISO shall not be held responsible for identifying any or all such patent rights. Details of any patent rights identified during the development of the document will be in the Introduction and/or on the ISO list of patent declarations received (see [www.iso.org/patents](http://www.iso.org/patents)).

Any trade name used in this document is information given for the convenience of users and does not constitute an endorsement.

For an explanation of the voluntary nature of standards, the meaning of ISO specific terms and expressions related to conformity assessment, as well as information about ISO's adherence to the World Trade Organization (WTO) principles in the Technical Barriers to Trade (TBT), see [www.iso.org/iso/foreword.html](http://www.iso.org/iso/foreword.html).

This document was prepared by Technical Committee ISO/TC 299, *Robotics*.

A list of all parts in the ISO 18646 series can be found on the ISO website.

Any feedback or questions on this document should be directed to the user's national standards body. A complete listing of these bodies can be found at [www.iso.org/members.html](http://www.iso.org/members.html).

## Introduction

This document defines characteristics for the manipulation performance of service robots and describes how to specify and test them. It is intended that the reader of this document selects which performance characteristics to test, in accordance with the specific requirements.

The performance criteria specified in this document are not intended to be interpreted as the verification or validation of safety requirements. The verification and validation of safety requirements are specified in safety related standards developed by ISO/TC 299.

Tests for position and path accuracy of manipulators, which can be useful in addition to the tests specified in this document, are provided in ISO 9283.

Tests for locomotion of mobile robots, such as rated speed and stopping characteristics are provided in ISO 18646-1. Tests for pose accuracy and pose repeatability for mobile robots are also provided in ISO 18646-2.

**iTeh STANDARD PREVIEW**  
**(standards.iteh.ai)**

ISO 18646-3:2021

<https://standards.iteh.ai/catalog/standards/sist/65c77530-8331-4c1a-808c-1621001e0646/iso-18646-3-2021>

**iTeh STANDARD PREVIEW**  
**(standards.iteh.ai)**

ISO 18646-3:2021

<https://standards.iteh.ai/catalog/standards/sist/65c77530-8331-4c1a-808c-1621001e0646/iso-18646-3-2021>

# Robotics — Performance criteria and related test methods for service robots —

## Part 3: Manipulation

### 1 Scope

This document describes methods of specifying and evaluating the manipulation performance of service robots, notably:

- grasp size;
- grasp strength;
- grasp slip resistance;
- opening a hinged door; and
- opening a sliding door.

There are other grasping characteristics and use cases for manipulation of service robots. It is expected that these will be included in a future revision.

This document deals with the indoor environment only. However, the depicted tests can also be applicable for robots operating in outdoor environments.

This document is not applicable for the verification or validation of safety requirements.

### 2 Normative references

The following documents are referred to in the text in such a way that some or all of their content constitutes requirements of this document. For dated references, only the edition cited applies. For undated references, the latest edition of the referenced document (including any amendments) applies.

ISO 9379:2005, *Operating forces — Test method — Doors*

### 3 Terms and definitions

For the purposes of this document, the following terms and definitions apply.

ISO and IEC maintain terminological databases for use in standardization at the following addresses:

- ISO Online browsing platform: available at <https://www.iso.org/obp>
- IEC Electropedia: available at <http://www.electropedia.org/>

#### 3.1

##### **robot**

programmed actuated mechanism with a degree of autonomy to perform locomotion, manipulation or positioning

Note 1 to entry: A *robot* includes the control system.

EXAMPLE *Manipulator, mobile platform, and wearable robot.*

[SOURCE: ISO 8373:2012, 2.6, modified — The phrase “actuated mechanism programmable in two or more axes” is replaced with “programmed actuated mechanism”, the phrase “moving within its environment, to perform intended tasks” is replaced with “to perform locomotion, manipulation or positioning”, note 1 to entry is modified, note 2 is removed, and EXAMPLES are added]

**3.2  
service robot**

*robot* that performs useful tasks for humans or equipment excluding industrial automation applications

Note 1 to entry: Industrial automation applications include, but are not limited to, manufacturing, inspection, packaging, and assembly.

Note 2 to entry: While articulated *robots* used in production lines are industrial *robots*, similar articulated *robots* used for serving food are *service robots*.

[SOURCE: ISO 8373:2012, 2.10]

**3.3  
mobile platform**

assembly of all components of the mobile *robot* which enables locomotion

Note 1 to entry: A *mobile platform* can include a chassis which can be used to support a load.

Note 2 to entry: Because of possible confusion with the term “base”, it is advisable not to use the term “mobile base” to describe a *mobile platform*.

[SOURCE: ISO 8373:2012, 3.18]

ITeH STANDARD PREVIEW  
(standards.iteh.ai)

**3.4  
manipulator**

mechanism usually consisting of a series of segments, connected to one another by joints, for the purpose of grasping and/or moving objects usually in several degrees of freedom

ISO 18646-3:2021  
<https://standards.iteh.ai/catalog/standards/sist/65c77530-8331-4c1a-808c-621021d4e661/iso-18646-3-2021>

Note 1 to entry: A *manipulator* does not include an *end effector*.

[SOURCE: ISO 8373:2012, 2.1, modified — The phrase “machine in which the mechanism usually consists of” is replaced with “mechanism usually consisting of”, the phrase “jointed or sliding relative to one another” is replaced with “connected to one another by joints”, the phrase “(pieces or tools)” is removed, and note 1 is removed]

**3.5  
end effector**

device specifically designed for attachment to the mechanical interface to enable the *robot* to perform its task

EXAMPLE *Gripper, nut runner, welding gun, spray gun.*

[SOURCE: ISO 8373:2012, 3.11]

**3.6  
gripper**

*end effector* designed for seizing and holding

[SOURCE: ISO 8373:2012, 3.14]

**3.7  
palm**

solid member in the basic mechanical structure of a *gripper* on which the first joints of fingers are fixed

Note 1 to entry: A *palm* may make direct contact to objects.

[SOURCE: ISO 14539:2000, 4.2.1.2]



**3.8****normal operating conditions**

range of environmental conditions and other parameters within which the *robot* is expected to perform as specified by the manufacturer

Note 1 to entry: Environmental conditions include, for example, temperature and humidity.

Note 2 to entry: Other parameters include electrical supply instability, electromagnetic fields, etc.

[SOURCE: ISO 8373:2012, 6.1, modified — The phrase “which can influence robot performance (such as electrical supply instability, electromagnetic fields) within which the performance of the robot (2,6) specified by the manufacturer is valid” is replaced with “within which the robot is expected to perform as specified by the manufacturer”, and note 2 to entry is added]

**3.9****autonomous mode**

operational mode in which the *robot* function accomplishes its assigned task without direct human intervention

[SOURCE: ISO 13482:2014, 3.24.2, modified — The word “mission” is replaced with “task” and the EXAMPLE has been removed.]

**3.10****test configuration**

particular arrangement of test objects

**3.11****trial**

single instance of test procedure performed under identical *test configuration*

Note 1 to entry: A trial can be repeated multiple times.

<https://standards.iteh.ai/catalog/standards/sist/65c77530-8331-4c1a-808c-1621001e0646/iso-18646-3-2021>

**4 Test conditions****4.1 General**

The service robot, hereafter referred to as robot, shall be completely assembled, configured with a mobile platform, if applicable, a manipulator and a gripper, sufficiently charged and operational. If there are any diagnostic tests that have to be performed before the normal operation, they shall be satisfactorily completed. Appropriate precautions should be taken to protect the personnel during the test. The tests shall be preceded by the preparations for operation as specified by the manufacturer.

All performance shall be measured under normal operating conditions and these conditions shall be included in the test report.

All sensors used in the test specified in this document shall be calibrated prior to performing any tests.

The robot may use any sensors and recognition means to identify the object for each test, as long as they are reported in the test report.

All conditions specified in this clause should be satisfied for the tests described in this document, unless it is stated otherwise in the specific subclauses.

**4.2 Operational mode**

Each test described in this document shall be carried out in the autonomous mode of the service robot.

### 4.3 Test configuration and trial

Each test described in this document can have multiple test configurations which require separate test procedures. For each test configuration, multiple trials shall be conducted, if specified in the test procedure.

## 5 Grasping characteristics

### 5.1 General

The goal of the tests described in this clause is to confirm the performance for the grasping characteristics, partially derived from Falco, et al., 2019<sup>[4]</sup> and Falco et al., 2015<sup>[5]</sup>. Three characteristics are addressed in this clause, but additional grasping characteristics exist. It is expected that more grasping characteristics and detailed test methodologies will be introduced in a future revision.

### 5.2 Grasp size

#### 5.2.1 Purpose

The purpose of this test is to confirm that the robot can grasp and move the objects of maximum and minimum sizes.

#### 5.2.2 Test facility

The setup for this test is shown in Figure 1. Three test objects of cylindrical, parallelepiped, and spherical type, shown in Table 1, are used for this test. The test objects should be made of PVC (Polyvinyl Chloride). If the manufacturer chooses a material other than PVC, the substituted material's name and physical properties (e.g. weight) shall be recorded in the test report.

The maximum and minimum sizes of each object, specifically  $D$  for cylindrical and spherical objects and  $W$  for parallelepiped object, are tested. These sizes can be provided by the manufacturer of robot or the tester, considering the size of the gripper.

Cylindrical and parallelepiped test objects shall have a length,  $L$ , longer than the lateral width of the gripper. For cylindrical and parallelepiped objects, the gripper shall hold the object along the longitudinal direction, meaning that grasping the object by two end faces (see Table 1) is not allowed.

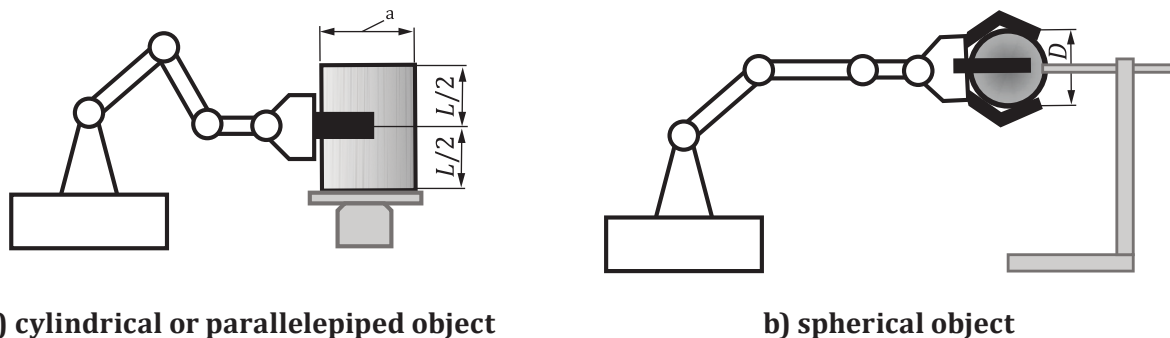

#### Key

<sup>a</sup>  $D$  or  $W$ .

Figure 1 — Test setup for grasp size

Table 1 — Test objects for grasping characteristics

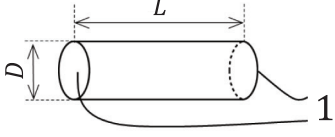
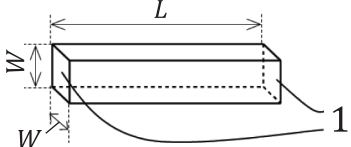
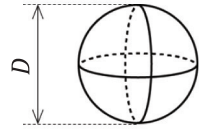
Name	Geometry	Description
Cylindrical object		L: Length D: Diameter
(Square) Parallelepiped object		L: Length W: Width
Spherical object		D: Diameter
<p>The test objects may have a hollow part so that the total weight of the gripper and test object is within the maximum load of the robot. In this case, the shape, dimensions, and weight of the test objects shall be declared in the test report.</p> <p><b>Key</b></p> <p>1 end face</p>		

The object should be placed so that the number of contacts between the gripper and the test object is maximized. For example, the contact with the palm of the gripper is encouraged to hold the test object securely, if possible.

A support or fixture may be used to ensure the stable vertical position of the test object, as shown in [Figure 1](#).

The robot shall be able to hold the object without dropping during the test. Manufacturer or tester shall decide the designated velocity and acceleration of the motions in the test.

### 5.2.3 Test procedure

This test consists of six test configurations of the cylindrical, parallelepiped and spherical objects with the maximum and minimum sizes.

Each trial shall follow the following procedure:

- A robot configured with the proper manipulator and gripper is placed at the initial pose where the gripper is around the geometric centre of the test object ([Figure 1](#)).
- The gripper grasps the test object and then the robot moves 100 mm upward at the designated velocity and acceleration (Pose A).
- The robot moves to the worst-case pose declared by the manufacturer (Pose B) at the designated velocity and acceleration and maintains this pose for 1 s. Pose B should be located sufficiently far away from Pose A as to enable the designated velocity to be attained during the movement.

**NOTE** If the manufacturer does not provide a “worst-case” pose for the gripper, for the purpose of this test, Pose B can be assumed to be such that the gripper’s aperture opening is pointed downward such that gravity is pulling the test object toward that opening.

- The robot moves back to Pose A at the designated velocity and acceleration.
- The robot returns to its initial pose and releases the test object.

The trial is repeated 10 times for each test object and size. The test is a success if the test object is held without dropping for all 10 trials. Otherwise, the test fails.