



Designation: D3038 – 93 (Reapproved 2010)

Standard Test Method for Drop Shatter Test for Coke¹

This standard is issued under the fixed designation D3038; the number immediately following the designation indicates the year of original adoption or, in the case of revision, the year of last revision. A number in parentheses indicates the year of last reapproval. A superscript epsilon (ϵ) indicates an editorial change since the last revision or reapproval.

1. Scope

1.1 This test method covers the application of two procedures for the determination of the property of coke of withstanding breakage when dropped under specified test conditions.

1.2 *Procedure A*, used when the coke sample contains 50 % or less of 100 mm (4 in.) after removal of coke smaller than 50 mm (2 in.). Procedure A appears in Sections 6 – 9.

1.3 *Procedure B*, used when the coke sample contains more than 50 % 100 mm (4 in.) after removal of coke smaller than 50 mm (2 in.). Procedure B appears in Sections 10 – 13.

1.4 The values stated in SI units are to be regarded as standard. The values given in parentheses are for information only.

1.5 *This standard does not purport to address all of the safety concerns, if any, associated with its use. It is the responsibility of the user of this standard to establish appropriate safety and health practices and determine the applicability of regulatory limitations prior to use.*

2. Referenced Documents

2.1 *ASTM Standards:*²

D121 Terminology of Coal and Coke

D293 Test Method for the Sieve Analysis of Coke

D346 Practice for Collection and Preparation of Coke Samples for Laboratory Analysis

D4621 Guide for Quality Management in an Organization That Samples or Tests Coal and Coke (Withdrawn 2010)³

E11 Specification for Woven Wire Test Sieve Cloth and Test Sieves

E323 Specification for Perforated-Plate Sieves for Testing Purposes

¹ This test method is under the jurisdiction of ASTM Committee D05 on Coal and Coke and is the direct responsibility of Subcommittee D05.15 on Metallurgical Properties of Coal and Coke.

Current edition approved May 1, 2010. Published May 2010. Originally approved in 1972. Last previous edition approved in 2004 as D3038 – 93 (2004). DOI: 10.1520/D3038-93R10.

² For referenced ASTM standards, visit the ASTM website, www.astm.org, or contact ASTM Customer Service at service@astm.org. For *Annual Book of ASTM Standards* volume information, refer to the standard's Document Summary page on the ASTM website.

³ The last approved version of this historical standard is referenced on www.astm.org.

3. Significance and Use

3.1 The values determined in this test, when evaluated in terms of pertinent experience with other cokes, may be used as indications of the extent to which a given coke will break in conventional transit and handling beyond the point of sampling.

4. Apparatus

4.1 *Shatter Apparatus*, including (1) box, (2) base plate, (3) support frame, (4) containers, (5) sieves, and (6) weighing scales (see Fig. 1).

4.1.1 *Box*, 455 mm (18 in.) in width, 710 mm (28 in.) in length, and 380 mm (15 in.) in depth. The bottom of the box shall consist of two doors, hinged lengthwise and provided with a trip latch for rapid opening. The doors are of 6-mm ($\frac{1}{4}$ -in.) plate and are mounted on freely working hinges so that they swing open rapidly and do not impede the fall of the coke. The sides of the box are made of plate at least 3 mm ($\frac{1}{8}$ in.) thick.

4.1.2 *Base Plate*—Steel plate, 1.22 m (48 in.) in length, 965 mm (38 in.) in width, and not less than 13 mm ($\frac{1}{2}$ in.) thick. Vertical plates at least 200 mm (8 in.) high are placed on all four sides to form a shallow box and to prevent loss of coke during the test. The back plate and side plates are rigidly fixed while the front plate is made removable to facilitate shovelling the coke from the base plate into the box after each drop. It is important that the base plate be supported rigidly.

NOTE 1—Mounting the base plate solidly on concrete is satisfactory.

4.1.3 *Support Frame*—A support frame and other appropriate mechanism are provided so the box may be readily raised and lowered to fixed or reproducible upper and lower positions. No part of the supporting frame is to impede the free fall of coke nor protrude into the 1.22- by 0.965-m (48- by 38-in.) area of the base plate. When in the upper position, the inside surface of the bottom of the box must be 1.83 m (6 ft) above the plate. The lower position shall be one convenient for loading and reloading the box without breakage of coke. The box may be constrained to only vertical movement by suitable lateral guides and may be conveniently supported by wire rope passing over pulleys. Counterweighting will reduce labor.

4.1.4 *Containers*—Conventional galvanized-iron tubs are convenient containers in which to collect and weigh coke in the various stages of the test.

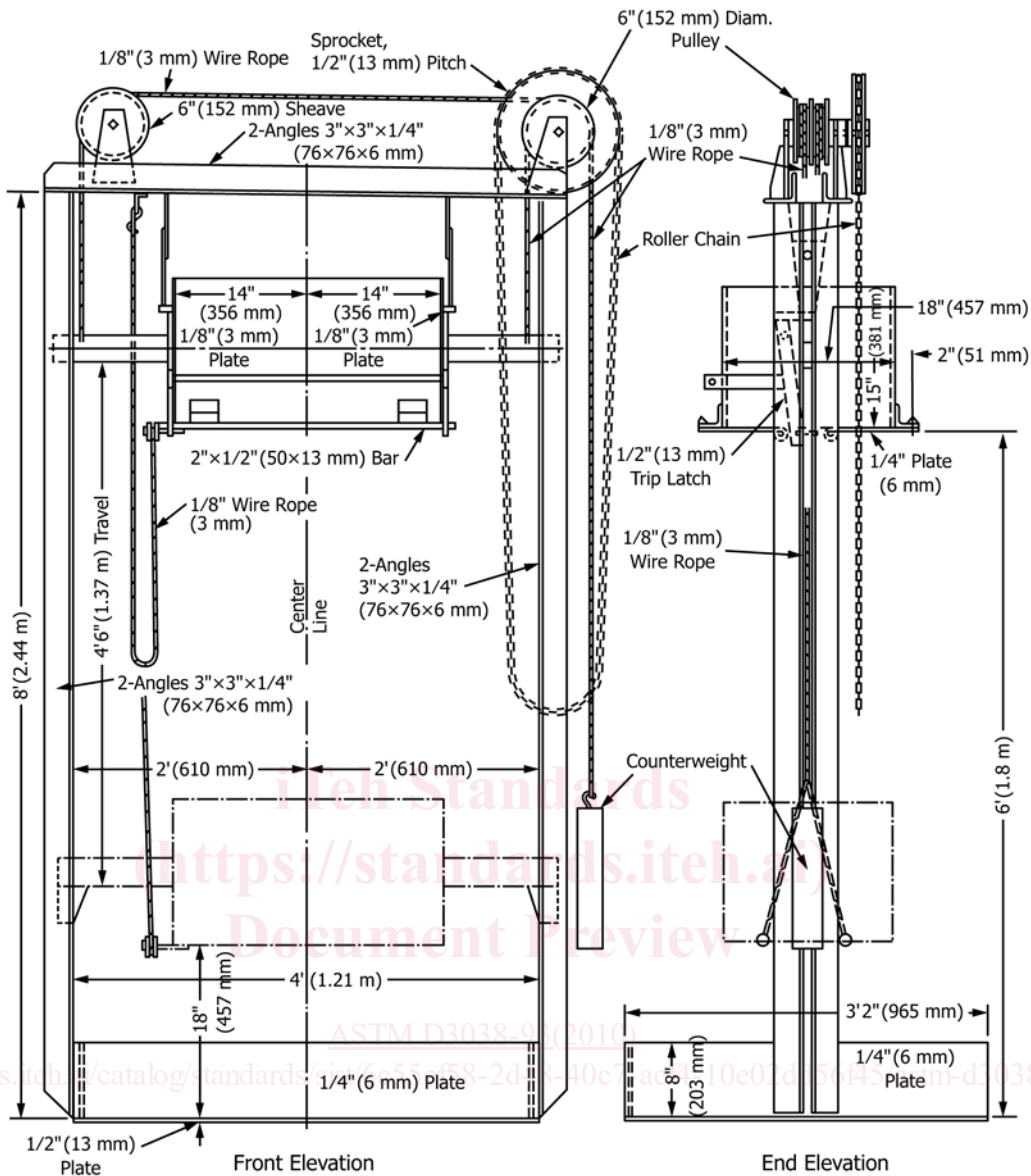

FIG. 1 Shatter Test Machine

4.1.5 *Sieves*—Woven-wire square-mesh sieves of the following sizes: 150 mm (6 in.), 125 mm (5 in.), 100 mm (4 in.), 75 mm (3 in.), 50 mm (2 in.), 37.5 mm (1½ in.), 25 mm (1 in.), and 12.5 mm (½ in.). The sieves must conform to Specification E11.

NOTE 2—The 150-mm (6-in.) and the 125-mm (5-in.) sieves are not defined in Specifications E11 but shall have nominal wire diameters of 7.11 mm (0.2800 in.) and 6.73 mm (0.2650 in.), respectively, and have permissible variations in average opening, permissible variations for not more than 5% of openings, and maximum variation in individual openings equivalent to that specified for the 100-mm (4-in.) sieve.

NOTE 3—For Procedure A, in which the coke samples do not contain more than 50% plus 100-mm (4-in.) sizes, the 150-mm (6-in.), 125-mm (5-in.), and 100-mm (4-in.) sieves may be excluded. For Procedure B, in which the coke samples contain more than 50% plus 100-mm (4-in.) sizes, it is permissible to exclude the 37.5-mm (1½-in.), 25-mm (1-in.), and the 12.5-mm (½-in.) sieves.

4.1.6 *Weighing Scale*—For Procedure A, a scale having a capacity of 35 kg (75 lb) is to be provided and be graduated so that it may be read directly, without interpolation, to 0.05 kg (0.1 lb). The sensitivity is to be not less than 0.025 kg (0.05 lb).

4.1.6.1 For Procedure B, this scale is to have a capacity of 60 kg (125 lb) graduated to 0.1 kg (0.2 lb) and have a sensitivity not less than 0.05 kg (0.10 lb).

5. Sampling

5.1 The gross sample of coke must be taken as close as possible to the point of interest, include all sizes, and be collected in such a way as to be representative of the total lot or quantity in question, in accordance with Practice D346.

5.2 For Procedure A, the minimum size of the gross sample must be such as to yield 68 to 75 kg (150 to 165 lb) of coke