**Hydraulic fluid power — Electrically
modulated hydraulic control valves —
Part 3:
Test methods for pressure control
valves**

*Transmissions hydrauliques — Distributeurs hydrauliques à
modulation électrique —*

*Partie 3: Méthodes d'essai pour distributeurs de commande de
pression*

Document Preview

ISO 10770-3:2020

<https://standards.iteh.ai/catalog/standards/iso/9db6249e-7986-4dbc-8667-abf4bf1b3e42/iso-10770-3-2020>



iTeh Standards
(<https://standards.iteh.ai>)
Document Preview

[ISO 10770-3:2020](https://standards.iteh.ai/catalog/standards/iso/9db6249e-7986-4dbc-8667-abf4bf1b3e42/iso-10770-3-2020)

<https://standards.iteh.ai/catalog/standards/iso/9db6249e-7986-4dbc-8667-abf4bf1b3e42/iso-10770-3-2020>



COPYRIGHT PROTECTED DOCUMENT

© ISO 2020

All rights reserved. Unless otherwise specified, or required in the context of its implementation, no part of this publication may be reproduced or utilized otherwise in any form or by any means, electronic or mechanical, including photocopying, or posting on the internet or an intranet, without prior written permission. Permission can be requested from either ISO at the address below or ISO's member body in the country of the requester.

ISO copyright office
CP 401 • Ch. de Blandonnet 8
CH-1214 Vernier, Geneva
Phone: +41 22 749 01 11
Fax: +41 22 749 09 47
Email: copyright@iso.org
Website: www.iso.org

Published in Switzerland

Contents

Page

Foreword	v
Introduction	vi
1 Scope	1
2 Normative references	1
3 Terms, definitions and symbols	1
3.1 Terms and definitions.....	1
3.2 Symbols.....	2
4 Standard test conditions	3
5 Test installation	3
6 Accuracy	6
6.1 Instrument accuracy.....	6
6.2 Dynamic range.....	7
7 Electrical tests for valves without integrated electronics	7
7.1 General.....	7
7.2 Coil resistance.....	7
7.2.1 Coil resistance (cold).....	7
7.2.2 Coil resistance (hot).....	7
7.3 Coil inductance (optional test).....	7
8 Relief valve	9
8.1 Steady-state tests.....	9
8.1.1 General.....	9
8.1.2 Proof pressure tests (optional).....	9
8.1.3 Internal leakage test.....	10
8.1.4 Test to establish the valve-controlled pressure versus input signal characteristic with constant flow.....	11
8.1.5 Threshold test.....	12
8.1.6 Pressure versus flow with constant input signal.....	13
8.1.7 Pressure versus fluid temperature.....	15
8.2 Dynamic tests.....	16
8.2.1 General.....	16
8.2.2 Test circuit.....	16
8.2.3 Step response (change in input signal).....	17
8.2.4 Step response (change in flow).....	19
8.2.5 Frequency response.....	21
9 Reducing valve	22
9.1 Steady-state tests.....	22
9.1.1 General.....	22
9.1.2 Proof pressure test (optional).....	23
9.1.3 Pilot flow test.....	23
9.1.4 Test to establish the valve-controlled pressure versus input signal characteristics with constant flow.....	24
9.1.5 Threshold.....	25
9.1.6 Valve pressure versus flow characteristic with constant input signal.....	26
9.1.7 Controlled pressure versus fluid temperature.....	29
9.2 Dynamic tests.....	29
9.2.1 General.....	29
9.2.2 Test circuit.....	30
9.2.3 Step response (change in input signal).....	30
9.2.4 Step response (change in flow).....	30
9.2.5 Frequency response.....	33

10	Pressure impulse test	33
11	Presentation of results	34
11.1	General.....	34
11.2	Test reports.....	34
11.2.1	General.....	34
11.2.2	Test reports for production acceptance tests.....	34
11.2.3	Test reports for type test.....	35
12	Identification statement	35
Annex A (informative) Testing guidance		36
Bibliography		37

iTeh Standards
(<https://standards.itih.ai>)
Document Preview

[ISO 10770-3:2020](https://standards.itih.ai/catalog/standards/iso/9db6249e-7986-4dbc-8667-abf4bf1b3e42/iso-10770-3-2020)

<https://standards.itih.ai/catalog/standards/iso/9db6249e-7986-4dbc-8667-abf4bf1b3e42/iso-10770-3-2020>

Foreword

ISO (the International Organization for Standardization) is a worldwide federation of national standards bodies (ISO member bodies). The work of preparing International Standards is normally carried out through ISO technical committees. Each member body interested in a subject for which a technical committee has been established has the right to be represented on that committee. International organizations, governmental and non-governmental, in liaison with ISO, also take part in the work. ISO collaborates closely with the International Electrotechnical Commission (IEC) on all matters of electrotechnical standardization.

The procedures used to develop this document and those intended for its further maintenance are described in the ISO/IEC Directives, Part 1. In particular, the different approval criteria needed for the different types of ISO documents should be noted. This document was drafted in accordance with the editorial rules of the ISO/IEC Directives, Part 2 (see www.iso.org/directives).

Attention is drawn to the possibility that some of the elements of this document may be the subject of patent rights. ISO shall not be held responsible for identifying any or all such patent rights. Details of any patent rights identified during the development of the document will be in the Introduction and/or on the ISO list of patent declarations received (see www.iso.org/patents).

Any trade name used in this document is information given for the convenience of users and does not constitute an endorsement.

For an explanation of the voluntary nature of standards, the meaning of ISO specific terms and expressions related to conformity assessment, as well as information about ISO's adherence to the World Trade Organization (WTO) principles in the Technical Barriers to Trade (TBT) see www.iso.org/iso/foreword.html.

This document was prepared by Technical Committee ISO/TC 131, *Fluid power systems*, Sub-committee SC 8, *Product testing*.

This second edition cancels and replaces the first edition (ISO 10770-3:2007), which has been technically revised.

A list of all parts in the ISO 10770 series can be found on the ISO website.

Any feedback or questions on this document should be directed to the user's national standards body. A complete listing of these bodies can be found at www.iso.org/members.html.

Introduction

This document describes methods of testing electro-hydraulic pressure relief and pressure reducing valves. These types of electro-hydraulic valves prevent the pressure in a hydraulic system rising above a level defined or set by an electrical input signal.

Relief valves are used to control the pressure in a closed volume by increasing the flow out of the volume if the pressure exceeds the set pressure level. The excess flow is dumped directly to a tank.

Reducing valves are used to control the pressure in a closed volume by restricting the flow into the volume if the pressure exceeds the set pressure level.

The design of the system and the position of the valve within the system dictates which type of valve is appropriate to use.

This document has been prepared with the intention of improving the uniformity of valve testing and hence the consistency of recorded valve performance data so that these data can be used for system design, regardless of the data source.

iTeh Standards
(<https://standards.iteh.ai>)
Document Preview

[ISO 10770-3:2020](https://standards.iteh.ai/catalog/standards/iso/9db6249e-7986-4dbc-8667-abf4bf1b3e42/iso-10770-3-2020)

<https://standards.iteh.ai/catalog/standards/iso/9db6249e-7986-4dbc-8667-abf4bf1b3e42/iso-10770-3-2020>

Hydraulic fluid power — Electrically modulated hydraulic control valves —

Part 3: Test methods for pressure control valves

1 Scope

This document describes test methods for determining the performance characteristics of electrically modulated hydraulic pressure control valves.

2 Normative references

The following documents are referred to in the text in such a way that some or all of their content constitutes requirements of this document. For dated references, only the edition cited applies. For undated references, the latest edition of the referenced document (including any amendments) applies.

ISO 3448:1992, *Industrial liquid lubricants — ISO viscosity classification*

ISO 4406, *Hydraulic fluid power — Fluids — Method for coding the level of contamination by solid particles*

ISO 5598, *Fluid power systems and components — Vocabulary*

ISO 6743-4, *Lubricants, industrial oils and related products (class L) — Classification — Part 4: Family H (Hydraulic systems)*

ISO 9110-1:1990, *Hydraulic fluid power — Measurement techniques — Part 1: General measurement principles*

ISO 10771-1, *Hydraulic fluid power — Fatigue pressure testing of metal pressure-containing envelopes — Part 1: Test method*

3 Terms, definitions and symbols

For the purposes of this document, the terms and definitions given in ISO 5598 and the following apply.

ISO and IEC maintain terminological databases for use in standardization at the following addresses:

- ISO Online browsing platform: available at <https://www.iso.org/obp>
- IEC Electropedia: available at <http://www.electropedia.org/>

3.1 Terms and definitions

3.1.1

electrically modulated pressure control valve

valve that limits the pressure in a hydraulic system to a level that is continuously variable and proportional to an electrical input signal

3.1.2

electrically modulated relief valve

valve that limits the pressure at the inlet port by dumping excess flow to the tank port

3.1.3

electrically modulated reducing valve

valve that limits the pressure at the outlet port by reducing the flow taken from the inlet port

3.1.4

controlled pressure

pressure difference between inlet and outlet of the relief valve under test or the pressure at the outlet of the reducing valve under test

3.1.5

controlled pressure volume

total volume of fluid in a test rig directly connected to the inlet of the relief valve under test, or the outlet of the reducing valve under test

3.1.6

head loss

minimum pressure drop through a valve

Note 1 to entry: The head loss is plotted as pressure versus flow.

3.1.7

reference pressure

controlled pressure measured at 10 % of rated flow

3.2 Symbols

For the purposes of this document, the symbols given in [Table 1](#) apply:

Table 1 — Symbols

Parameter	Symbol	Unit
Frequency	f	Hz
Input signal	I or U	A or V
Rated signal	I_N or U_N	A or V
Current readout	I_{READ}	A
Pressure gain	$K_p = (\Delta p / \Delta I \text{ or } \Delta p / \Delta U)$	bar (per input signal unit)
Inductance	L_C	H
Supply pressure	p_P	MPa (bar)
Return pressure	p_T	MPa (bar)
Controlled pressure	p_C	MPa (bar)
Valve pressure drop	$p_V = p_P - p_T$	MPa (bar)
Rated pressure	p_N	MPa (bar)
Output flow	q	l/min
Rated flow	q_N	l/min
Internal leakage	q_I	l/min
Insulation resistance	R_i	Ω
Resistance	R_C	Ω
Time	t	s
Time constant	t_C	s
Dither amplitude	—	% (of max. input signal)
Dither frequency	—	Hz
Hysteresis	—	% (of max. output)
Threshold	—	% (of maximum input)

Table 1 (continued)

Parameter	Symbol	Unit
Amplitude (ratio)	—	dB
Phase lag	—	°
Temperature	—	°C

The graphical symbols in this document conform to ISO 1219-1 and IEC 60617-DB.

4 Standard test conditions

Unless otherwise specified, tests shall be carried out using the standard conditions given in [Table 2](#).

Table 2 — Standard test conditions

Parameter	Condition
Ambient temperature	20 °C ± 5 °C
Filtration	Solid contaminant code number shall be stated in accordance with ISO 4406.
Fluid type	Commercially available mineral based hydraulic fluid (i.e. L – HL in accordance with ISO 6743-4 or other fluid with which the valve is able to operate).
Fluid viscosity	32 cSt ± 8 cSt at valve inlet
Viscosity grade	Grade VG32 or VG46 in accordance with ISO 3448:1992.
Supply pressure	Test requirement ±2,5 %
Return pressure	Return pressure shall conform to the manufacturer's recommendations.

5 Test installation

SAFETY PRECAUTION — It is essential that consideration is given to the safety of personnel and equipment during the tests.

A test installation conforming to the requirements of [Figure 1](#), [Figure 2](#) or [Figure 3](#) shall be used for testing all valves. [Figures 1](#) to [3](#) show the minimum items required to carry out the tests without any safety devices to protect against damage in the event of component failure. For tests using the test circuits shown in [Figures 1](#) to [3](#), the following apply:

- a) Guidance on carrying out the tests is given in [Annex A](#).
- b) A separate circuit may be constructed for each type of test. This can improve the accuracy of test results as it eliminates the possibility of leakage through the shut-off valves.
- c) Hydraulic performance tests are carried out on a combination of valve and amplifier. Input signals are applied to the amplifier and not directly to the valve. For electrical tests, the signals are applied directly to the valve.
- d) If possible, hydraulic tests should be conducted using an amplifier, recommended by the valve manufacturer. If not, the type of amplifier used should be recorded, with the operating details (i.e. pulse width modulation frequency, dither frequency and amplitude).
- e) The amplifier supply voltage and magnitude and sign of the voltage applied to the valve during the on and off periods of the pulse-width modulation should be recorded.
- f) Electronic test equipment and transducers should have a bandwidth or natural frequency at least ten times greater than the maximum test frequency.
- g) Flow transducer 10 shall be selected to have negligible effect on the pressure at port Y.

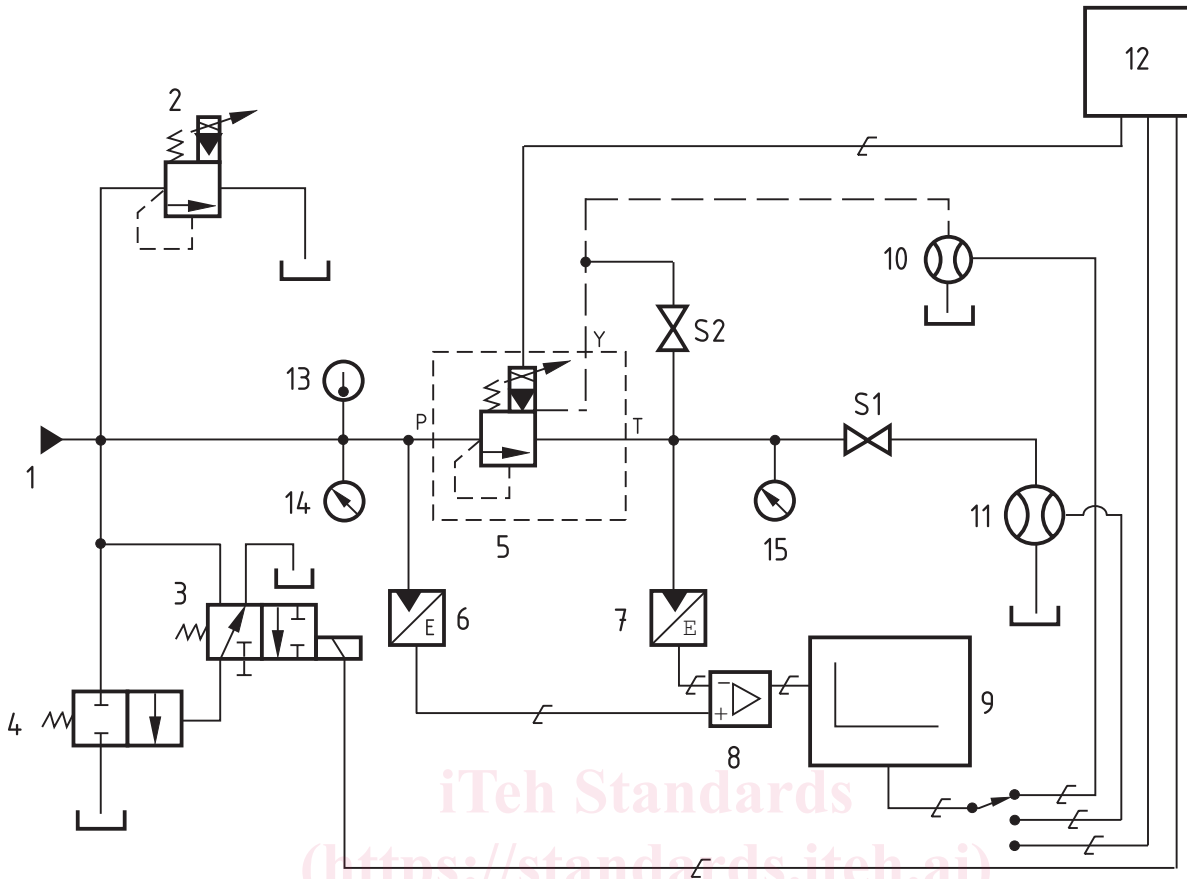

Key

- | | | | |
|----|---------------------------------|----|-----------------------|
| 1 | flow source | 11 | flow transducer |
| 2 | system relief valve | 12 | signal generator |
| 3 | pilot valve for unloading valve | 13 | temperature indicator |
| 4 | unloading valve | 14 | pressure gauge |
| 5 | unit under test | 15 | pressure gauge |
| 6 | pressure transducer | S1 | shut-off valve |
| 7 | pressure transducer | S2 | shut-off valve |
| 8 | differential amplifier | P | supply port |
| 9 | data acquisition | T | return port |
| 10 | flow transducer | Y | pilot-drain port |

Figure 1 — Relief-valve test circuit

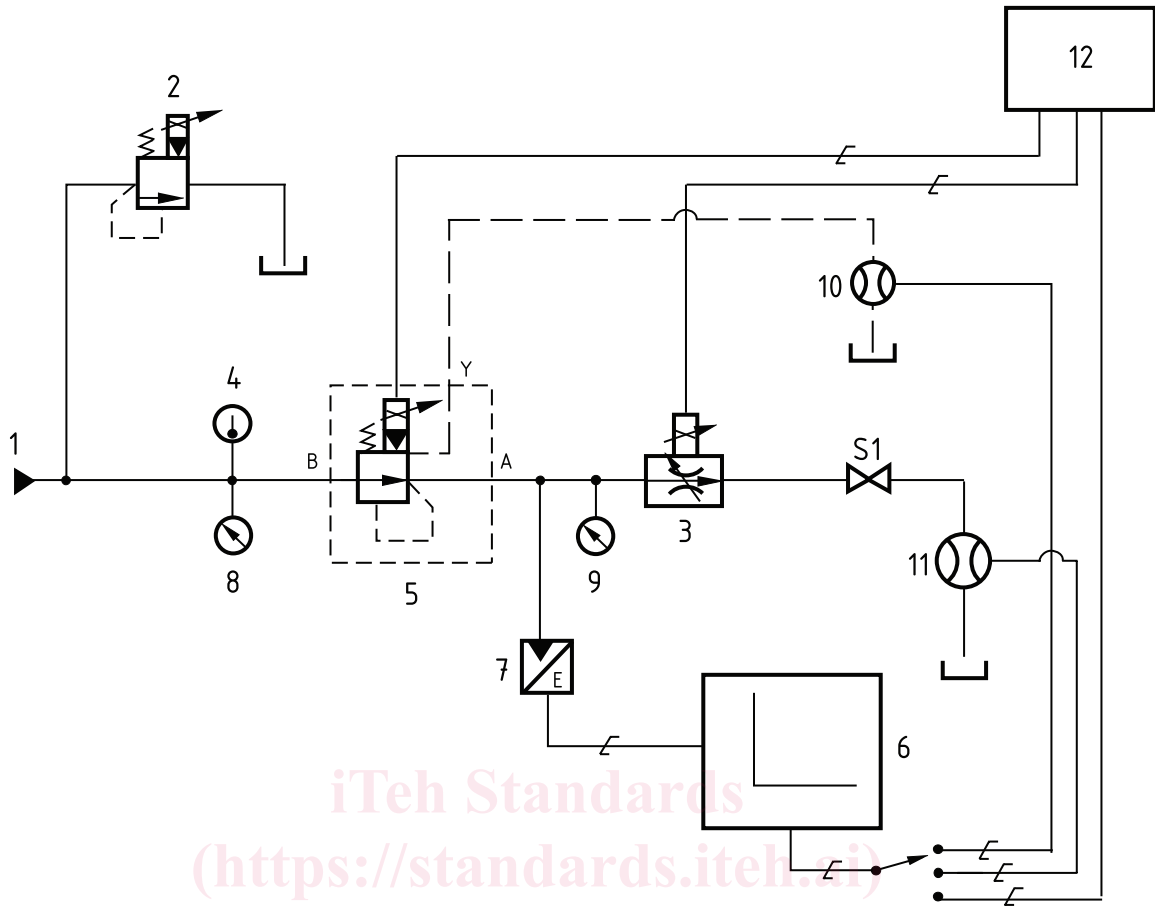

Key

- | | | | |
|---|-----------------------|----|-----------------------|
| 1 | flow source | 9 | pressure gauge |
| 2 | system relief valve | 10 | flow transducer |
| 3 | flow control valve | 11 | flow transducer |
| 4 | temperature indicator | 12 | signal generator |
| 5 | unit under test | A | control-pressure port |
| 6 | data acquisition | B | inlet-pressure port |
| 7 | pressure transducer | S1 | shut-off valve |
| 8 | pressure gauge | Y | pilot-drain port |

Figure 2 — Reducing valve test circuit

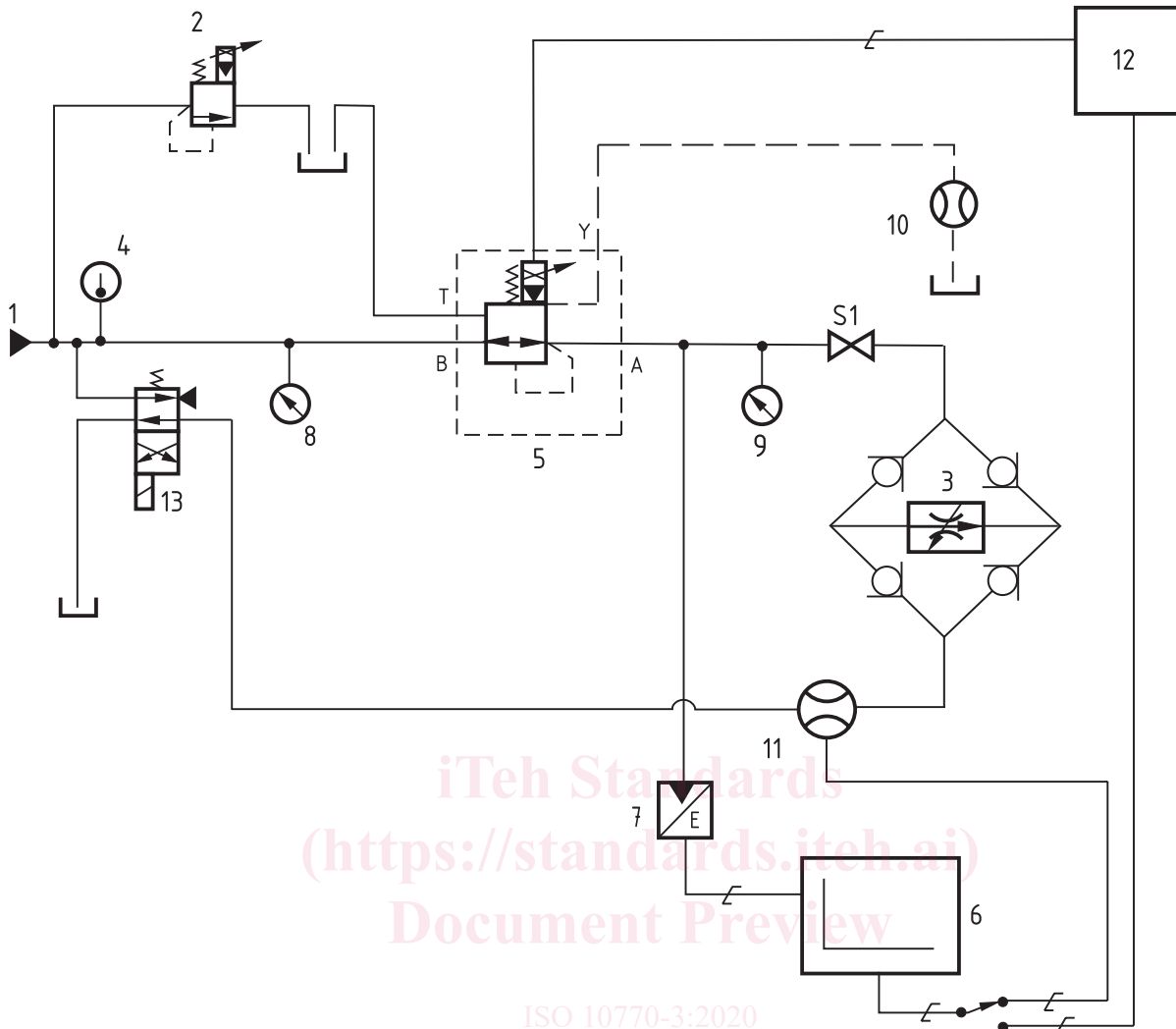

iTeh Standards
 (https://standards.iteh.ai)
 Document Preview

ISO 10770-3:2020

Key

- | | | | |
|---|-----------------------|----|-----------------------|
| 1 | flow source | 10 | flow transducer |
| 2 | system relief valve | 11 | flow transducer |
| 3 | flow control valve | 12 | signal generator |
| 4 | temperature indicator | 13 | directional valve |
| 5 | unit under test | A | control-pressure port |
| 6 | data acquisition | B | inlet-pressure port |
| 7 | pressure transducer | S1 | shut-off valve |
| 8 | pressure gauge | T | return pressure port |
| 9 | pressure gauge | Y | pilot-drain port |

Figure 3 — Reducing valve with reverse flow test circuit

6 Accuracy

6.1 Instrument accuracy

Instrumentation shall be accurate to within the limits specified in ISO 9110-1:1990, Class B:

- a) electrical resistance: $\pm 2\%$ of the actual measurement;