**Adhesives — Test methods for
adhesives for floor and wall coverings
— Shear test**

*Adhésifs — Méthodes d'essai d'adhésifs pour revêtements du sol et
muraux — Essai de cisaillement*

iTeh STANDARD PREVIEW
(standards.iteh.ai)

[ISO 22632:2019](https://standards.iteh.ai/catalog/standards/sist/f6b6adc6-a1be-4c37-8b96-b155cba64e35/iso-22632-2019)

[https://standards.iteh.ai/catalog/standards/sist/f6b6adc6-a1be-4c37-8b96-
b155cba64e35/iso-22632-2019](https://standards.iteh.ai/catalog/standards/sist/f6b6adc6-a1be-4c37-8b96-b155cba64e35/iso-22632-2019)



iTeh STANDARD PREVIEW
(standards.iteh.ai)

ISO 22632:2019

<https://standards.iteh.ai/catalog/standards/sist/f6b6adc6-a1be-4c37-8b96-b155cba64e35/iso-22632-2019>



COPYRIGHT PROTECTED DOCUMENT

© ISO 2019

All rights reserved. Unless otherwise specified, or required in the context of its implementation, no part of this publication may be reproduced or utilized otherwise in any form or by any means, electronic or mechanical, including photocopying, or posting on the internet or an intranet, without prior written permission. Permission can be requested from either ISO at the address below or ISO's member body in the country of the requester.

ISO copyright office
CP 401 • Ch. de Blandonnet 8
CH-1214 Vernier, Geneva
Phone: +41 22 749 01 11
Fax: +41 22 749 09 47
Email: copyright@iso.org
Website: www.iso.org

Published in Switzerland

Contents

	Page
Foreword	iv
1 Scope	1
2 Normative references	1
3 Terms and definitions	1
4 Principle	2
5 Apparatus and materials	2
6 Preparation of the test specimens	4
6.1 Cleaning	4
6.2 Sampling of adhesive	4
6.3 Conditioning of materials	4
6.3.1 Adhesive and floor and wall coverings	4
6.3.2 Fibre cement substrate	4
6.3.3 Plywood substrates	4
6.4 Application of adhesive	4
6.5 Bonding of the test covering	5
7 Conditioning of the test specimens	5
8 Test procedure	5
9 Evaluation and expression of results	6
10 Test report	7
Bibliography	8

<https://standards.iteh.ai/catalog/standards/sist/f6b6adc6-a1be-4c37-8b96-b155cba64e35/iso-22632-2019>
 ISO 22632:2019
 (standards.iteh.ai)

Foreword

ISO (the International Organization for Standardization) is a worldwide federation of national standards bodies (ISO member bodies). The work of preparing International Standards is normally carried out through ISO technical committees. Each member body interested in a subject for which a technical committee has been established has the right to be represented on that committee. International organizations, governmental and non-governmental, in liaison with ISO, also take part in the work. ISO collaborates closely with the International Electrotechnical Commission (IEC) on all matters of electrotechnical standardization.

The procedures used to develop this document and those intended for its further maintenance are described in the ISO/IEC Directives, Part 1. In particular, the different approval criteria needed for the different types of ISO documents should be noted. This document was drafted in accordance with the editorial rules of the ISO/IEC Directives, Part 2 (see www.iso.org/directives).

Attention is drawn to the possibility that some of the elements of this document may be the subject of patent rights. ISO shall not be held responsible for identifying any or all such patent rights. Details of any patent rights identified during the development of the document will be in the Introduction and/or on the ISO list of patent declarations received (see www.iso.org/patents).

Any trade name used in this document is information given for the convenience of users and does not constitute an endorsement.

For an explanation of the voluntary nature of standards, the meaning of ISO specific terms and expressions related to conformity assessment, as well as information about ISO's adherence to the World Trade Organization (WTO) principles in the Technical Barriers to Trade (TBT) see www.iso.org/iso/foreword.html.

This document was prepared by Technical Committee ISO/TC 61, *Plastics*, Subcommittee SC 11, *Products*.

<https://standards.iteh.ai/catalog/standards/sist/f6b6adc6-a1be-4c37-8b96->

Any feedback or questions on this document should be directed to the user's national standards body. A complete listing of these bodies can be found at www.iso.org/members.html.

Adhesives — Test methods for adhesives for floor and wall coverings — Shear test

SAFETY PRECAUTIONS — Persons using this document should be familiar with the normal laboratory practice, if applicable. This document does not purport to address all of the safety problems, if any, associated with its use. It is the responsibility of the user to establish appropriate safety and health practices.

ENVIRONMENTAL STATEMENT — It is understood that some of the material permitted in this document may have negative environmental impact. As technological advantages lead to acceptable alternatives for these materials, they will be eliminated from this document to the extent possible. At the end of the test, it is essential that the user of this document take care to carry out an appropriate disposal of the wastes.

1 Scope

This document specifies a test method to measure the adhesion of a resilient or textile floor covering or wall covering bonded to a given substrate under shear forces. The term “wall covering” does not include any type of wallpaper.

2 Normative references

The following documents are referred to in the text in such a way that some or all of their content constitutes requirements of this document. For dated references, only the edition cited applies. For undated references, the latest edition of the referenced document (including any amendments) applies.

ISO 472, *Plastics — Vocabulary*

ISO 554, *Standard atmospheres for conditioning and/or testing — Specifications*

ISO 7500-1, *Metallic materials — Calibration and verification of static uniaxial testing machines — Part 1: Tension/compression testing machines — Calibration and verification of the force-measuring system*

ISO 9142, *Adhesives — Guide to the selection of standard laboratory ageing conditions for testing bonded joints*

ISO 10365, *Adhesives — Designation of main failure patterns*

ISO 15605, *Adhesives — Sampling*

EN 1067, *Adhesives — Examination and preparation of samples for testing*

3 Terms and definitions

For the purposes of this document, the terms and definitions given in ISO 472 and the following apply.

ISO and IEC maintain terminological databases for use in standardization at the following addresses:

- ISO Online browsing platform: available at <https://www.iso.org/obp>
- IEC Electropedia: available at <http://www.electropedia.org/>

3.1 covering

flexible resilient or textile floor covering or wall covering

3.2 adhesive for coverings

adhesive which is intended to produce firm and durable bonds between *coverings* (3.1) and various substrates

4 Principle

The adhesion is determined by measuring the shear strength under specified conditions before and after storing the bonds at 23 °C/50 °C under specified conditions.

5 Apparatus and materials

5.1 Notched trowel (for the shape of the notch, see [Figure 1](#)), with dimensions *a*, *b* and *c* specified by the adhesive manufacturer.

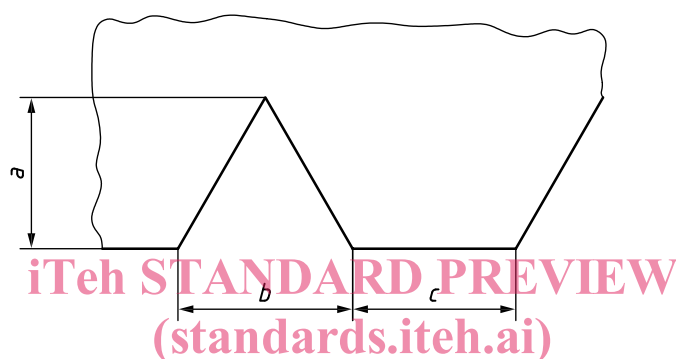

Key

- a* notch depth
- b* notch width
- c* notch distance

ISO 22632:2019
<https://standards.iteh.ai/catalog/standards/sist/f6b6adc6-a1be-4c37-8b96-b155cba64e35/iso-22632-2019>

Figure 1 — Shape of notches of notched trowel

5.2 Roller, of width (60 ± 5) mm, diameter (90 ± 5) mm and total mass (3,50 ± 0,05) kg with handle at 90° to the axis (as an example, see [Figure 2](#)).

Dimensions in millimetres

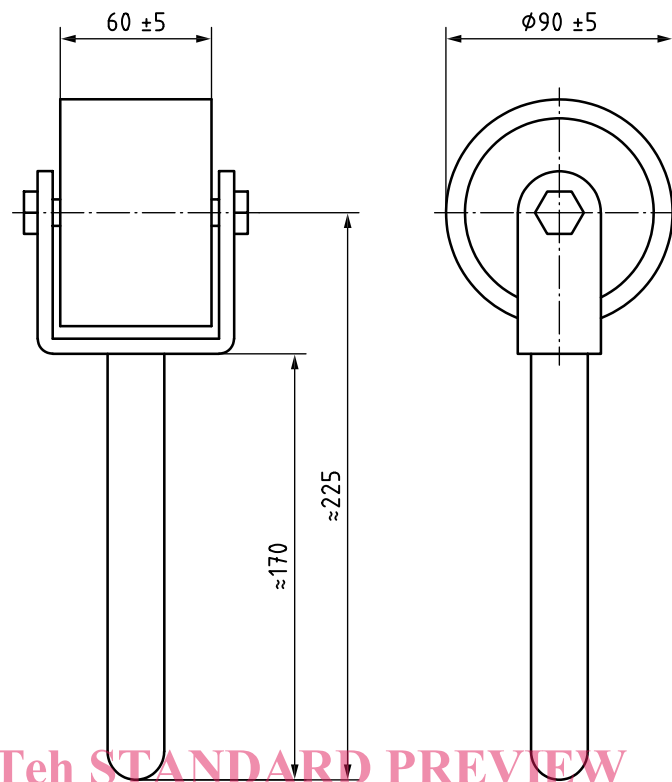

iTeh STANDARD PREVIEW
(standards.iteh.ai)
Figure 2 — Roller

NOTE The length of the handle is not critical and can be used for setting the total mass.

5.3 Heating chamber, ventilated and adjustable to a temperature between 20 °C and 200 °C according to ISO 9142.

5.4 Tensile testing machine, conforming to ISO 7500-1, class 1.

5.5 Primer, if applicable.

5.6 Test covering, five test pieces for each conditioning sequence of dimensions 60 mm × 50 mm, the long side, running in the machine direction where this can be identified, and shall be taken at least 10 mm from the edge.

5.7 Substrate materials.

Use either fibre cement or plywood as the substrate.

5.7.1 Fibre cement substrate, one uncoated fibre cement panel, fully compressed and autoclaved, for each test piece. Five fibre cement panels for each conditioning sequence with a length of approximately 60 mm and a thickness of approximately 8,0 mm. The width is (50 ± 0,5) mm.

NOTE Length and thickness are not critical.

Depending on the source of the fibre cement panels, the surfaces sometimes differ with respect to gloss, absorbency and strength. In this case, it is important to do some preliminary assessment (i.e. peel tests) of the panels to identify the preferred side for testing. The preferred side is referred to as the upper side of the substrate in this document.

If failure of the substrate is the main finding of the preliminary assessment, a suitable primer may be used for testing.

5.7.2 Plywood substrate, one uncoated plywood panel for each test piece. Five plywood panels for each conditioning sequence with a length of approximately 60 mm and a thickness of approximately 5,0 mm. The width is $(50 \pm 0,5)$ mm.

NOTE Length and thickness are not critical.

6 Preparation of the test specimens

6.1 Cleaning

Ensure that all test coverings and substrate materials are clean and free from dust, loose particles or other contamination.

6.2 Sampling of adhesive

Take a sample in accordance with ISO 15605 of the adhesive to be tested and examine and prepare it in accordance with EN 1067.

6.3 Conditioning of materials

6.3.1 Adhesive and floor and wall coverings

Condition the materials at a standard atmosphere of (23 ± 2) °C and (50 ± 5) % relative humidity in accordance with ISO 554 for at least 24 h prior to use.

6.3.2 Fibre cement substrate

Place the test panels (5.7.1) in a heating chamber (5.3) for 6 h at (80 ± 2) °C. Ensure that the test panels are spaced in such a way as to enable a free passage of air over them. At the end of this period, remove the test panels from the heating chamber and store for 48 h in a standard atmosphere of (23 ± 2) °C and (50 ± 5) % relative humidity prior to use.

6.3.3 Plywood substrates

Condition the materials at a standard atmosphere of (23 ± 2) °C and (50 ± 5) % relative humidity in accordance with ISO 554 for at least 24 h prior to use.

6.4 Application of adhesive

Place masking tape across one end of the upper side of each substrate leaving a 20 mm length to be coated with adhesive.

Apply the adhesive under test across the full width of the substrate using a notched trowel (5.1), held at an angle of approximately 60°, steadily down the length of the substrate to provide a uniform adhesive application.

Remove the masking tape when the adhesive has been applied.

When applying the adhesive, it is essential that the serrated blade is kept clean and free of adhesive build-up. Clean the blade regularly (no more than five substrates to be prepared without cleaning). In addition, regularly check the notch size and depth, especially where non-hardened steel blades are in use.

6.5 Bonding of the test covering

After the time recommended by the adhesive manufacturer (i.e. minimum open time in accordance with ISO 472), place the test covering (5.6) onto the coated panel (5.7) to provide an overlap of 20 mm such that the unbonded length protrudes from the edge of the panel coated with adhesive (see Figure 3).

Dimensions in millimetres

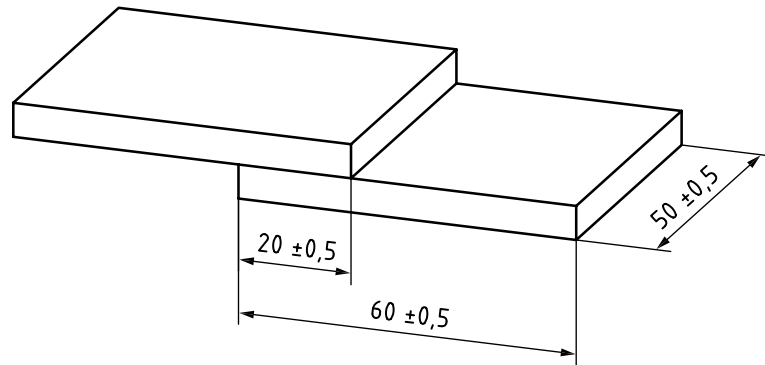

Figure 3 — Shear test specimen

Immediately after positioning the test covering, roll the test specimen with a roller (5.2) by passing forward and backward once along the test specimen without any additional pressure being applied.

As the adhesive has not yet set it should be ensured that the overlapping area remains 20 mm × 50 mm without any shift during the subsequent treatments of the test coverings.

Before applying the roller, it is advisable to support the unbonded area of the test covering by an additional panel of the same thickness in order to avoid tilting.

To prevent the test covering from slipping caused by the roller, an appropriate frame or mould for the substrate sheets in combination with range spacers can be used for the covering.

For coverings which show a tendency to curl after rolling, a dead load of $(2,0 \pm 0,1)$ kg mass can be applied for $(3,0 \pm 0,5)$ h. The load is spread evenly over the whole surface thus ensuring a contact over the total bonded area of each test specimen. The procedure applied should be recorded in the test report [see Clause 10 i)].

7 Conditioning of the test specimens

After assembly, expose the test specimens to the conditions as given in Table 1.

Table 1 — Conditioning

Control test	Test I	Test II ^a
28 days at a standard atmosphere of 23/50 (see ISO 554)	7 days at a standard atmosphere of 23/50 (see ISO 554)	
	20 days at (50 ± 2) °C (see ISO 3205)	41 days at (50 ± 2) °C (see ISO 3205)
	1 day at a standard atmosphere of 23/50 (see ISO 554)	

^a This test to be optional for determining the effect of any type of interaction between an adhesive and a covering.

8 Test procedure

Clamp the ends of the test specimen in appropriate clamps of the tensile testing machine (5.4) using packings to ensure that the axis of the test specimen is aligned with the direction of the clamp movement (see Figure 4).