

ISO/TC 61/SC 11

ISO 22637:2019(E)

ISO/TC 61/SC 11/WG 5

Secretariat: JISC

Adhesives — Test of adhesives for floor covering — Determination of the electrical resistance of adhesive films and composites

Adhésifs — Essai de adhésifs pour revêtements de sol — Détermination de la résistance électrique de films adhésifs et d'assemblages

iTeh STANDARD PREVIEW
(standards.iteh.ai)

ISO 22637:2019

<https://standards.iteh.ai/catalog/standards/sist/4a0bdeef-0747-4161-ac99-a8e358b7ce51/iso-22637-2019>

Document type: International Standard
Document subtype:
Document stage: (60) Publication
Document language: E

Document1 STD Version 2.2

Style Definition: List Continue 5:
Font: Indent: Hanging: 20.15 pt,
Don't add space between
paragraphs of the same style

Style Definition: RefNorm

Style Definition: Base_Text: Tab
stops: 19.85 pt, Left + 39.7 pt, Left +
59.55 pt, Left + 79.4 pt, Left +
99.25 pt, Left + 119.05 pt, Left +
138.9 pt, Left + 158.75 pt, Left +
178.6 pt, Left + 198.45 pt, Left

Style Definition: BodyText_Center

Style Definition: Code: Tab stops:
16.15 pt, Left + 32.6 pt, Left +
48.75 pt, Left + 65.2 pt, Left +
81.35 pt, Left + 97.8 pt, Left +
113.95 pt, Left + 130.4 pt, Left +
146.55 pt, Left + 162.75 pt, Left

Style Definition: Dimension_100

Style Definition: Figure Graphic

Style Definition: Figure subtitle

Style Definition: List Continue 1

Style Definition: List Number 1:
Tab stops: Not at 20.15 pt

Style Definition: Example indent 2:
Tab stops: 67.7 pt, Left

Style Definition: Note indent 2
continued: Tab stops: 87.9 pt, Left

Style Definition: Note indent 2

Deleted: Date: 2019-04-01¶

Deleted: /PRF

Deleted: /PRF

Deleted: Copyright notice¶

This ISO document is a Draft International Standard and is copyright-protected by ISO. Except as permitted under the applicable laws of the user's country, neither this ISO draft nor any extract from it may be reproduced, stored in a retrieval system or transmitted in any form or by any means, electronic, photocopying, recording or otherwise, without prior written permission being secured.¶

Requests for permission to reproduce should be addressed to either ISO at the address below or ISO's member body in the country of the requester.¶

ISO copyright office¶

Case postale 56 • CH-1211 Geneva 20¶

Tel. + 41 22 749 01 11¶

Fax + 41 22 749 09 47¶

E-mail copyright@iso.org¶

Web www.iso.org¶

Reproduction may be subject to royalty payments or a licensing agreement.¶

Violators may be prosecuted.¶

iTeh STANDARD PREVIEW
(standards.iteh.ai)

ISO 22637:2019

<https://standards.iteh.ai/catalog/standards/sist/4a0bdeef-0747-4161-ac99-a8e358b7ce51/iso-22637-2019>

Contents	Page
Foreword	4
1 Scope	1
2 Normative references	1
3 Terms and definitions	1
4 Apparatus and materials	2
5 Preparation of test specimens	4
5.1 Preparation of test specimens for determination of adhesive resistance R_4	4
5.2 Preparation of test specimens for determination of vertical resistance of composite, R_5	5
6 Storing the specimens	5
6.1 Storing the specimens for determination of adhesive resistance R_4	5
6.2 Storing the specimens for determination of vertical resistance of composite R_5	6
7 Test procedure	6
7.1 General	6
7.2 Adhesive resistances, R_4	6
7.3 Vertical resistance of composite, R_5	6
8 Test report	6

(standards.iteh.ai)

ISO 22637:2019

<https://standards.iteh.ai/catalog/standards/sist/4a0bdeef-0747-4161-ac99-a8e358b7ce51/iso-22637-2019>

Foreword

ISO (the International Organization for Standardization) is a worldwide federation of national standards bodies (ISO member bodies). The work of preparing International Standards is normally carried out through ISO technical committees. Each member body interested in a subject for which a technical committee has been established has the right to be represented on that committee. International organizations, governmental and non-governmental, in liaison with ISO, also take part in the work. ISO collaborates closely with the International Electrotechnical Commission (IEC) on all matters of electrotechnical standardization.

The procedures used to develop this document and those intended for its further maintenance are described in the ISO/IEC Directives, Part 1. In particular, the different approval criteria needed for the different types of ISO documents should be noted. This document was drafted in accordance with the editorial rules of the ISO/IEC Directives, Part 2 (see www.iso.org/directives).

Deleted: www.iso.org/directives

Attention is drawn to the possibility that some of the elements of this document may be the subject of patent rights. ISO shall not be held responsible for identifying any or all such patent rights. Details of any patent rights identified during the development of the document will be in the Introduction and/or on the ISO list of patent declarations received (see www.iso.org/patents).

Deleted: www.iso.org/patents

Any trade name used in this document is information given for the convenience of users and does not constitute an endorsement.

For an explanation of the voluntary nature of standards, the meaning of ISO specific terms and expressions related to conformity assessment, as well as information about ISO's adherence to the World Trade Organization (WTO) principles in the Technical Barriers to Trade (TBT) see www.iso.org/iso/foreword.html.

Deleted: www.iso.org/iso/foreword.html

This document was prepared by Technical Committee ISO/TC 61, *Plastics*, Subcommittee SC 11, *Products*.

Any feedback or questions on this document should be directed to the user's national standards body. A complete listing of these bodies can be found at www.iso.org/members.html.

Deleted: www.iso.org/members.html

Adhesives — Test of adhesives for floor covering — Determination of the electrical resistance of adhesive films and composites

SAFETY STATEMENT — Persons using this document should be familiar with the normal laboratory practice, if applicable. This document does not purport to address all of the safety problems, if any, associated with its use. It is the responsibility of the user to establish appropriate safety and health practices.

ENVIRONMENTAL STATEMENT — It is understood that some of the material permitted in this document may have negative environmental impact. As technological advantages lead to acceptable alternatives for these materials, they will be eliminated from this document to the extent possible. At the end of the test, the user of the document should take care to carry out an appropriate disposal of the wastes.

1 Scope

This document specifies a test method to measure the electrical resistance as a material physical parameter of an adhesive film and composites of floor covering material and adhesive film. The electrical resistance is reciprocal to the electrical conductivity. This laboratory method does not take account of all influences which can occur in practice.

This method applies to the determination of the electrical resistance of adhesive films on glass and of composites of floor coverings, adhesively bonded to a fibre cement substrate R_4 and R_5 (see Clause 3).

2 Normative references

The following documents are referred to in the text in such a way that some or all of their content constitutes requirements of this document. For dated references, only the edition cited applies. For undated references, the latest edition of the referenced document (including any amendments) applies.

ISO 472, *Plastics — Vocabulary*

ISO 554, *Standard atmospheres for conditioning and/or testing — Specifications*

ISO 9142, *Adhesives — Guide to the selection of standard laboratory ageing conditions for testing bonded joints*

ISO 15605, *Adhesives — Sampling*

EN 1067, *Adhesives — Examination and preparation of samples for testing*

EN 1081:2018, *Resilient floor coverings — Determination of the electrical resistance*

3 Terms and definitions

For the purposes of this document, the terms and definitions given in ISO 472 and the following apply.

ISO 22637:2019(E)

Deleted: /PRF

ISO and IEC maintain terminological databases for use in standardization at the following addresses:

— ISO Online browsing platform: available at <https://www.iso.org/obp>

Deleted: <https://www.iso.org/obp>

— IEC Electropedia: available at <http://www.electropedia.org/>

Deleted: <http://www.electropedia.org/>

3.1 vertical resistance of floor covering

R_1
electrical resistance, measured at an unbounded floor covering sample between the tripod electrode on the surface of the floor covering and a second electrode on the opposite underside

3.2 resistance to ground

R_2
electrical resistance, measured at a bonded floor covering between a tripod electrode on the surface of the floor covering and ground

3.3 point to point resistance

R_3
electrical resistance measured on the surface of a bonded floor covering between two tripod electrodes in a distance of 100 mm

3.4 adhesive resistance

R_4
electrical resistance of a cured adhesive film, measured between two copper strips in a distance of 500 mm to each other

3.5 vertical resistance of composite

R_5
electrical resistance of a bonded floor covering, measured between a tripod electrode on the surface of the floor covering and a copper strip on the underside in a distance of 500 mm to each other

4 Apparatus and materials

4.1 Glass plate, dimensions: approximately 600 mm × 120 mm × 4 mm.

4.2 Uncoated fibre cement panels, fully compressed and autoclaved, asbestos free, with dimensions of approximately 750 mm × 300 mm × 6 mm.

4.3 Adhesive applicator with an opening of (1,0 ± 0,1) mm height and a width of (100 ± 1) mm (see Figure 1).

Dimensions in millimetres

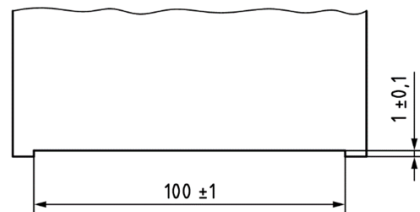

Figure 1 — Opening dimensions of the adhesive applicator

- 4.4 **Adhesive trowel**, serrated blade with a notch size specified by the adhesive manufacturer.
- 4.5 **Three copper strips**, preferably self-adhesive, dimensions: approximately 120 mm × 10 mm × 0,08 mm.
- 4.6 **Conductive floor covering**, dimensions: approximately 700 mm × 250 mm.
- 4.7 **Roller**, of width (60 ± 5) mm, diameter (90 ± 5) mm and total mass (3,50 ± 0,05) kg with handle at 90° to the axis (as an example, see Figure 2).

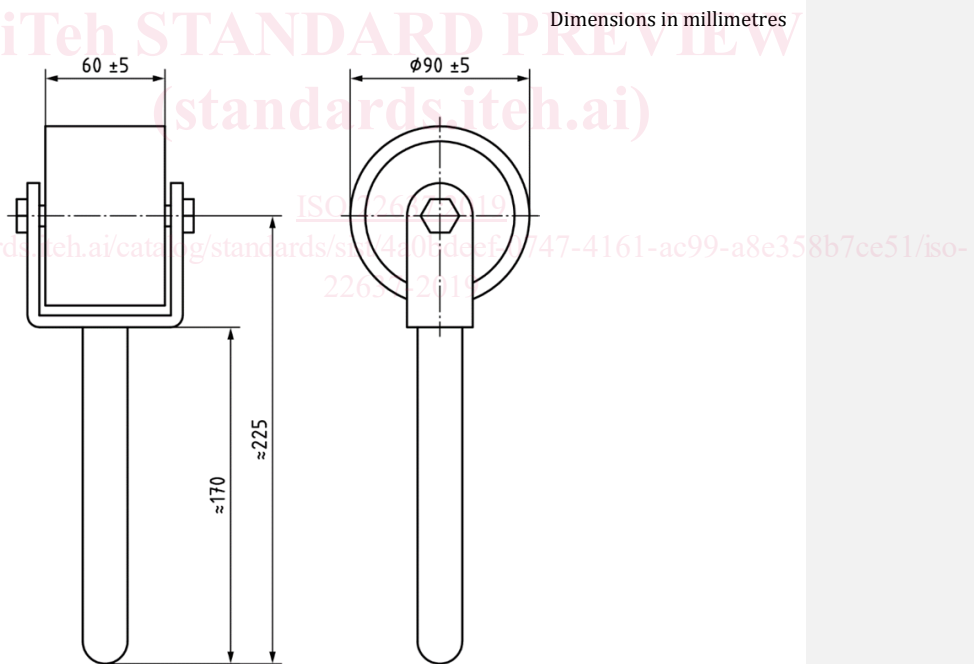

Figure 2 — Roller

NOTE The length of the handle is not critical and can be used for setting the total mass.

- 4.8 **Tripod electrode**, in accordance with EN 1081 (see EN 1081:2018, 5.1 and Figure 1).

4.9 Load, able to apply at least 300 N to the tripod electrode.

4.10 Resistance meter, calibrated, with an accuracy of $\pm 5\%$ for R values in the range of $10^3 \Omega$ to $10^{10} \Omega$, and of $\pm 10\%$ for more than $10^{10} \Omega$.

For resistances less than or equal to $10^6 \Omega$ the open circuit voltage shall be 10 V d.c., for resistances greater than $10^6 \Omega$ but not exceeding $10^{10} \Omega$ it shall be 100 V and for resistances greater than $10^{10} \Omega$ it shall be 500 V.

Recommended is a resistance meter with an inside resistance of 100 k Ω .

4.11 Heating chamber, ventilated and adjustable to a temperature between 20 °C and 200 °C according to ISO 9142.

5 Preparation of test specimens

5.1 Preparation of test specimens for determination of adhesive resistance, R_4

The side of the glass plate (4.1) intended for applying the adhesive shall be free of grease, dust and other contamination.

Take a sample of the adhesive to be tested in accordance with ISO 15605, examine and prepare it for testing in accordance with EN 1067.

Two copper strips (4.5) shall be affixed (500 ± 10) mm away from each other in parallel to the shorter edges on the glass plate, making sure they protrude about 30 mm beyond the edge of the plate.

Apply adhesive to produce a uniform thickness of 1 mm. A sufficient quantity of adhesive shall be applied to the prepared surface on one shorter edge of the plate. The adhesive shall be spread evenly using the applicator in accordance with 4.3, in parallel to the longer edge glass plate (see Figure 3).

ISO 22637:2019 Dimensions in millimetres

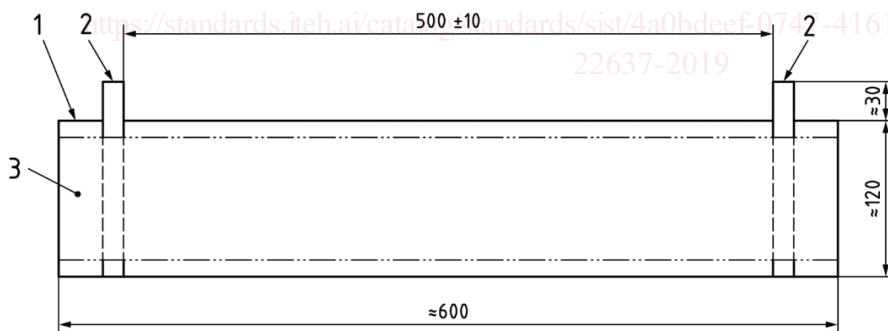

Key

- 1 glass plate
- 2 copper strip
- 3 adhesive film area

Figure 3 — Arrangements of the copper strips

5.2 Preparation of test specimens for determination of vertical resistance of composite, R_5

The fibre cement panel (4.2) shall be likewise free of dust and other contamination, and before the adhesive is applied be conditioned for 120 h at $(50 \pm 3)^\circ\text{C}$ in a heating chamber (4.11) and reconditioned for at least 8 h at standard atmosphere $23^\circ\text{C}/50\%$ according to ISO 554.

Deleted: dry heat

Take a sample of the adhesive to be tested in accordance with ISO 15605, examine and prepare it for testing in accordance with EN 1067.

A copper strip (4.5) shall be affixed parallel to the shorter edge of the fibre cement panel at the end of the panel making sure it protrudes about 30 mm beyond the edge of the panel. A sufficient quantity of adhesive shall be applied to the prepared surface on one shorter edge of the plate. The adhesive shall be spread evenly using the applicator in accordance with 4.4, in a width of 200 mm in the middle and parallel to the longer edge of cement panel.

After the open time specified by the adhesive's producer, the conductive floor coverings (4.6) being tested shall be laid into the adhesive bed flush against one short side, just in the middle of the two long sides of the carrier slab, and rolled on using the roller (4.7) by rolling it evenly back and forth three times without additional pressure (see Figure 4).

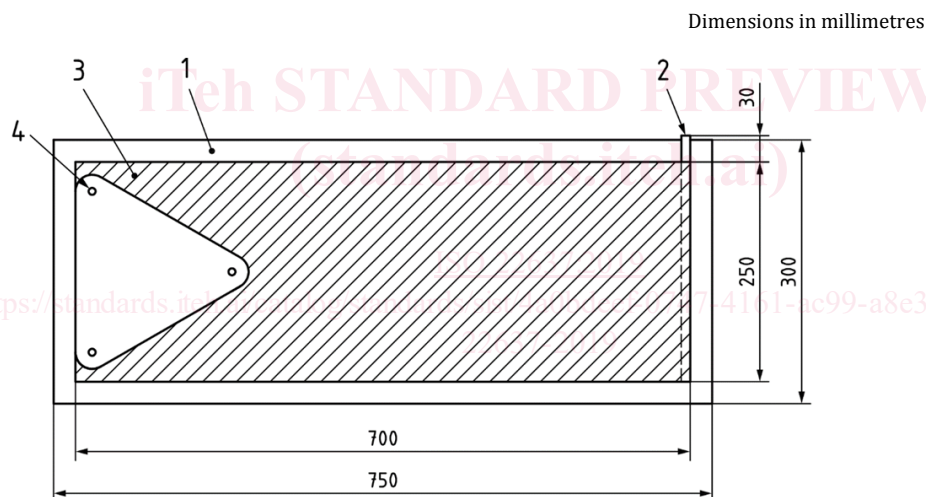

Key

- 1 support (fibre cement panel)
- 2 copper strip
- 3 adhesive film covered with floor covering
- 4 tripod electrode

Figure 4 — Fibre cement panel with bonded floor covering

6 Storing the specimens

6.1 Storing the specimens for determination of adhesive resistance, R_4

The samples are stored as follows:

- a) ~24 h at standard atmosphere $23^\circ\text{C}/50\%$ according to ISO 554;

ISO 22637:2019(E)

Deleted: /PRF

- b) 24 h at (40 ± 3) °C in a heating chamber (4.11);
- c) 48 h at standard atmosphere 23 °C/50 % according to ISO 554.

Deleted: dry heat

6.2 Storing the specimens for determination of vertical resistance of composite R_5

The samples are stored as follows:

- a) ~24 h at standard atmosphere 23 °C/50 % according to ISO 554;
- b) 96 h at (40 ± 3) °C in a heating chamber (4.11);
- c) 48 h at standard atmosphere 23 °C/50 % according to ISO 554.

Deleted: dry heat

7 Test procedure

7.1 General

The electrical resistances shall be measured following the storage period (see 6.1 and 6.2).

7.2 Adhesive resistances, R_4

The two copper strips are connected to the resistance meter (4.10).

Testing begins with 100 V test voltage, (15 ± 2) s after applying the test voltage the electrical resistance in ohms (Ω) shall be read. If the value exceeds 10^{10} Ω , the measuring shall be repeated with 500 V test voltage.

7.3 Vertical resistance of composite, R_5

The tripod electrode (4.8) is placed on the narrow side of the floor covering (see Figure 4) and loaded with at least 300 N. The electrode and the copper strip on the opposite underside are connected with the resistance meter. Testing begins with 10 V test voltage, (15 ± 2) s after applying the test voltage the electrical resistance in ohms (Ω) shall be read. If the value exceeds 10^6 Ω the measuring shall be repeated with 100 V test voltage. If the value exceeds 10^{10} Ω the final measuring shall be carried out with 500 V test voltage.

8 Test report

The test report shall include, at least, the following information:

- a) a reference to this document, i.e. ISO 22637:2019;
- b) designation and the adhesive batch number;
- c) designation of the floor covering;
- d) the conditioning sequences used;
- e) glass plate or fibre cement panel in accordance with 4.1 or 4.2;
- f) type of trowel used;
- g) open time in minutes (min);
- h) measuring electrodes used in accordance with 4.8;