**Fasteners — Hexagon washer head
drilling screws with tapping screw
thread**

*Fixations — Vis autoperceuses à tête hexagonale à embase plate, avec
filetage de vis à tôle*

iTeh STANDARD PREVIEW
(standards.iteh.ai)

ISO 15480:2019

<https://standards.iteh.ai/catalog/standards/sist/9c895e91-41cd-4167-9da3-a3d19d6e96a9/iso-15480-2019>



iTeh STANDARD PREVIEW
(standards.iteh.ai)

ISO 15480:2019

<https://standards.iteh.ai/catalog/standards/sist/9c895e91-41cd-4167-9da3-a3d19d6e96a9/iso-15480-2019>



COPYRIGHT PROTECTED DOCUMENT

© ISO 2019

All rights reserved. Unless otherwise specified, or required in the context of its implementation, no part of this publication may be reproduced or utilized otherwise in any form or by any means, electronic or mechanical, including photocopying, or posting on the internet or an intranet, without prior written permission. Permission can be requested from either ISO at the address below or ISO's member body in the country of the requester.

ISO copyright office
CP 401 • Ch. de Blandonnet 8
CH-1214 Vernier, Geneva
Phone: +41 22 749 01 11
Fax: +41 22 749 09 47
Email: copyright@iso.org
Website: www.iso.org

Published in Switzerland

Contents

	Page
Foreword	iv
1 Scope	1
2 Normative references	1
3 Terms and definitions	1
4 Dimensions	1
5 Requirements and reference International Standards	3
6 Designation	4
Bibliography	5

iTeh STANDARD PREVIEW (standards.iteh.ai)

[ISO 15480:2019](https://standards.iteh.ai/catalog/standards/sist/9c895e91-41cd-4167-9da3-a3d19d6e96a9/iso-15480-2019)

<https://standards.iteh.ai/catalog/standards/sist/9c895e91-41cd-4167-9da3-a3d19d6e96a9/iso-15480-2019>

Foreword

ISO (the International Organization for Standardization) is a worldwide federation of national standards bodies (ISO member bodies). The work of preparing International Standards is normally carried out through ISO technical committees. Each member body interested in a subject for which a technical committee has been established has the right to be represented on that committee. International organizations, governmental and non-governmental, in liaison with ISO, also take part in the work. ISO collaborates closely with the International Electrotechnical Commission (IEC) on all matters of electrotechnical standardization.

The procedures used to develop this document and those intended for its further maintenance are described in the ISO/IEC Directives, Part 1. In particular, the different approval criteria needed for the different types of ISO documents should be noted. This document was drafted in accordance with the editorial rules of the ISO/IEC Directives, Part 2 (see www.iso.org/directives).

Attention is drawn to the possibility that some of the elements of this document may be the subject of patent rights. ISO shall not be held responsible for identifying any or all such patent rights. Details of any patent rights identified during the development of the document will be in the Introduction and/or on the ISO list of patent declarations received (see www.iso.org/patents).

Any trade name used in this document is information given for the convenience of users and does not constitute an endorsement.

For an explanation of the voluntary nature of standards, the meaning of ISO specific terms and expressions related to conformity assessment, as well as information about ISO's adherence to the World Trade Organization (WTO) principles in the Technical Barriers to Trade (TBT) see www.iso.org/iso/foreword.html.

This document was prepared by Technical Committee ISO/TC 2, *Fasteners*, Subcommittee SC 13, *Fasteners with non-metric thread*.

This second edition cancels and replaces the first edition (ISO 15480:1999), which has been technically revised. The main changes compared to the previous edition are as follows:

- normative references updated;
- addition of diameter d_a in [Figure 1](#) and with respective values in [Table 1](#);
- l_g changed to l_m in [Figure 1](#) and [Table 1](#) in accordance with ISO 225;
- values for r_1 in [Table 1](#) changed to minimum values.

Any feedback or questions on this document should be directed to the user's national standards body. A complete listing of these bodies can be found at www.iso.org/members.html.

Fasteners — Hexagon washer head drilling screws with tapping screw thread

1 Scope

This document specifies the characteristics of hexagon washer head drilling screws with tapping screw threads, made of steel, with thread sizes ST2,9 to ST6,3, and with product grade A.

2 Normative references

The following documents are referred to in the text in such a way that some or all of their content constitutes requirements of this document. For dated references, only the edition cited applies. For undated references, the latest edition of the referenced document (including any amendments) applies.

ISO 1478, *Tapping screws thread*

ISO 3269, *Fasteners — Acceptance inspection*

ISO 4042, *Fasteners — Electroplated coating systems*

ISO 4759-1, *Tolerances for fasteners — Part 1: Bolts, screws, studs and nuts — Product grades A, B and C*

ISO 8992, *Fasteners — General requirements for bolts, screws, studs and nuts*

ISO 10666, *Drilling screws with tapping screw thread — Mechanical and functional properties*

<https://standards.iteh.ai/catalog/standards/sist/9c895e91-41cd-4167-9da3-a3d19d6e96a9/iso-15480-2019>

3 Terms and definitions

No terms and definitions are listed in this document.

ISO and IEC maintain terminological databases for use in standardization at the following addresses:

- ISO Online browsing platform: available at <https://www.iso.org/obp/ui/>
- IEC Electropedia: available at <http://www.electropedia.org/>

4 Dimensions

Dimensions shall be in accordance with [Figure 1](#) and [Table 1](#).

Symbols and descriptions of dimensions are defined in ISO 225.

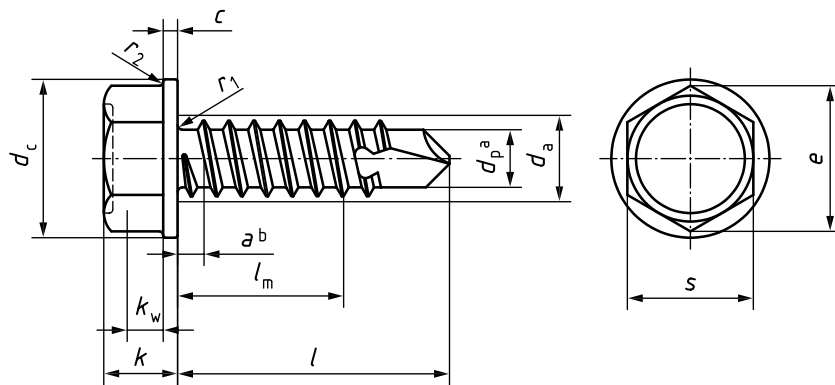

- a The function of the drilling point (diameter d_p) is specified in ISO 10666.
- b Dimension a shall be measured at the core diameter of the first full thread.

Figure 1 — Hexagon washer head drilling screw with tapping thread

iTeh STANDARD PREVIEW
(standards.iteh.ai)

ISO 15480:2019
<https://standards.iteh.ai/catalog/standards/sist/9c895e91-41cd-4167-9da3-a3d19d6e96a9/iso-15480-2019>

Table 1 — Dimensions

Dimensions in millimetres

Thread			ST2,9	ST3,5	ST4,2	ST4,8	ST5,5	ST6,3	
P_a			1,1	1,3	1,4	1,6	1,8	1,8	
a	max.		1,1	1,3	1,4	1,6	1,8	1,8	
c	min.		0,4	0,6	0,8	0,9	1,0	1,0	
d_a	max.		3,5	4,1	4,9	5,6	6,3	7,3	
d_c	max.		6,3	8,3	8,8	10,5	11,0	13,5	
	min.		5,8	7,6	8,1	9,8	10,0	12,2	
e	min.		4,28	5,96	7,59	8,71	8,71	10,95	
k	nom. = max		2,8	3,4	4,1	4,3	5,4	5,9	
	min.		2,5	3,0	3,6	3,8	4,8	5,3	
k_w^b	min.		1,3	1,5	1,8	2,2	2,7	3,1	
r_1	min.		0,1	0,1	0,2	0,2	0,25	0,25	
r_2	max.		0,2	0,25	0,3	0,3	0,4	0,5	
s	nom. = max		4,00 ^c	5,50	7,00	8,00	8,00	10,00	
	min.		3,82	5,32	6,78	7,78	7,78	9,78	
Drilling range (sheet or plate thickness) ^d			from	0,7	0,7	1,75	1,75	1,75	2,0
			to	1,9	2,25	3,0	4,4	5,25	6,0
l			l_m^e						
nom.	min.	max.	min.						
9,5	8,75	10,25	3,25	2,85	Screws with too short lengths				
13	12,1	13,9	16,6	15,480:2019 6,2					4,3
16	15,1	16,9	9,6	9,2	7,3	5,8	5,0		
19	18,0	20,0	12,5	12,1	10,3	8,7	8,0	7,0	
22	21,0	23,0	Lengths to be agreed between the purchaser and the manufacturer	15,1	13,3	11,7	11,0	10,0	
25	24,0	26,0		18,1	16,3	14,7	14,0	13,0	
32	30,75	33,25		23,0	21,5	21,0	20,0		
38	36,75	39,25		29,0	27,5	27,0	26,0		
45	43,75	46,25		34,5	34,0	33,0			
50	48,75	51,25		39,5	39,0	38,0			

^a P is the pitch of the thread.

^b k_w is the wrenching height.

^c Divergence from the width across flats for hexagon tapping screws in accordance with ISO 1479 (5 mm). In the case of hexagon washer head tapping screws (see ISO 7053), the width across flats of 4 mm has been introduced worldwide and also applies in this case.

^d In order to determine the nominal length l needed for the application, it can be necessary to add an air gap (if present) to the individual sheet or plate thickness(es).

^e l_m is the distance from the bearing face to the last major diameter of the thread.

5 Requirements and reference International Standards

The requirements specified in the International Standards listed in [Table 2](#) shall apply.

Table 2 — Requirements and reference International Standards

Material		Steel
	International Standard	ISO 10666
General requirements	International Standard	ISO 8992
Thread	International Standard	ISO 1478
Mechanical and functional properties	International Standard	ISO 10666
Tolerances	Product grade	A
	International Standard	ISO 4759-1
Finish — Coating		As processed (no coating) Electroplated coatings as specified in ISO 4042 Additional requirements or other finishes or coatings shall be agreed between the supplier and the purchaser.
Acceptability		Acceptance inspection as specified in ISO 3269

6 Designation

EXAMPLE A hexagon washer head drilling screw with tapping screw thread, with thread size ST3,5 and nominal length $l = 16$ mm, is designated as follows:

Hexagon head drilling screw ISO 15480 – ST3,5 × 16
(standards.iteh.ai)

[ISO 15480:2019](https://standards.iteh.ai/catalog/standards/sist/9c895e91-41cd-4167-9da3-a3d19d6e96a9/iso-15480-2019)

<https://standards.iteh.ai/catalog/standards/sist/9c895e91-41cd-4167-9da3-a3d19d6e96a9/iso-15480-2019>

Bibliography

- [1] ISO 225, *Fasteners — Bolts, screws, studs and nuts — Symbols and descriptions of dimensions*
- [2] ISO 1479, *Hexagon head tapping screws*
- [3] ISO 7053, *Hexagon washer head tapping screws*

iTeh STANDARD PREVIEW
(standards.iteh.ai)

[ISO 15480:2019](https://standards.iteh.ai/catalog/standards/sist/9c895e91-41cd-4167-9da3-a3d19d6e96a9/iso-15480-2019)

<https://standards.iteh.ai/catalog/standards/sist/9c895e91-41cd-4167-9da3-a3d19d6e96a9/iso-15480-2019>