



Designation: ~~C872-89~~ (Reapproved 2005) Designation: C872 - 10

## Standard Test Method for Lead and Cadmium Release from Porcelain Enamel Surfaces<sup>1</sup>

This standard is issued under the fixed designation C872; the number immediately following the designation indicates the year of original adoption or, in the case of revision, the year of last revision. A number in parentheses indicates the year of last reapproval. A superscript epsilon ( $\epsilon$ ) indicates an editorial change since the last revision or reapproval.

### INTRODUCTION

This test method covers the precise determination of lead or cadmium extracted by acetic acid from porcelain enamel surfaces. The procedure of extraction may be expected to accelerate the release of lead or cadmium and to serve, therefore, as a severe test that is unlikely to be matched under actual conditions of usage.

#### 1. Scope

1.1 This test method covers the precise determination of lead and cadmium extracted by acetic acid from porcelain enamel surfaces.

1.2 Values stated in SI units are to be regarded as the standard. Inch-pound units are given for information only.

1.3 *This standard does not purport to address all of the safety concerns, if any, associated with its use. It is the responsibility of the user of this standard to establish appropriate safety and health practices and determine the applicability of regulatory limitations prior to use.*

#### 2. Referenced Documents

2.1 *ASTM Standards:*<sup>2</sup>

C738 [Test Method for Lead and Cadmium Extracted from Glazed Ceramic Surfaces](#)

D1193 [Specification for Reagent Water](#)

#### 3. Summary of Test Method

3.1 The lead and cadmium extracted from the article under test by acetic acid at 20 to 24°C (68 to 75°F) after 24 h of leaching are measured by atomic absorption spectrophotometry using a specific hollow cathode lamp for lead and cadmium respectively.

#### 4. Significance and Use

4.1 The determination of lead and cadmium release from porcelain enamel surfaces was formerly of interest only to manufacturers of porcelain enamel cookware and similar food service products. Food contact surfaces of these container-type products have been evaluated using a test procedure similar to Test Method C738. Recently, however, there has been a need to measure lead and cadmium release from flat or curved porcelain enamel surfaces that are not capable of being evaluated by a test similar to Test Method C738.

#### 5. Interferences

5.1 Since a specific hollow cathode lamp for lead and cadmium is used, there are no interferences.

#### 6. Apparatus

6.1 *Atomic Absorption Spectrophotometer*, equipped with a 102-mm (4-in.) single slot or Boling burner head and digital

<sup>1</sup> This test method is under the jurisdiction of ASTM Committee B08 on Metallic and Inorganic Coatings and is the direct responsibility of Subcommittee B08.12 on Materials for Porcelain Enamel and Ceramic-Metal Systems.

Current edition approved Sept. 15, 2005. Published September 2005. Originally approved in 1977. Last previous edition approved in 1999 as C872-89 (1999). DOI: 10.1520/C0872-89R05. on Materials for Porcelain Enamel and Ceramic-Metal Systems.

Current edition approved April 1, 2010. Published May 2010. Originally approved in 1977. Last previous edition approved in 2005 as C872-89(2005). DOI: 10.1520/C0872-10.

<sup>2</sup> For referenced ASTM standards, visit the ASTM website, [www.astm.org](http://www.astm.org), or contact ASTM Customer Service at [service@astm.org](mailto:service@astm.org). For *Annual Book of ASTM Standards* volume information, refer to the standard's Document Summary page on the ASTM website.

concentration readout attachment (DCR) if available.<sup>3</sup> This instrument should have a sensitivity of about 0.5 mg/L of lead for 1 % absorption and a sensitivity of about 0.03 mg/L of cadmium for 1 % absorption. The operating conditions as specified in the instrument manufacturer's analytical methods manual shall be used.

NOTE 1—ppm, mg/L, and µg/mL are equivalent units.

6.2 *Hollow Cathode Lead Lamp*, with wavelength set at 283.3 or 217.0 nm.

6.3 *Hollow Cathode Cadmium Lamp*, with wavelength set at 228.8 nm.

6.4 *Glassware* of chemically resistant borosilicate glass, to make reagents and solutions.

6.5 *Test Cell*, suitable for the containment of the leaching solution on a flat porcelain enamel surface. A cell that has proved suitable for this purpose is shown in Fig. 1.

### 7. Reagents

7.1 *Purity of Reagents*—Reagent grade chemicals shall be used in all tests. Unless otherwise indicated, it is intended that all reagents shall conform to the specifications of the Committee on Analytical Reagents of the American Chemical Society, where

<sup>3</sup> Perkin-Elmer model 303 and Jarrell-Ash model 82-546 have been found suitable for this determination.

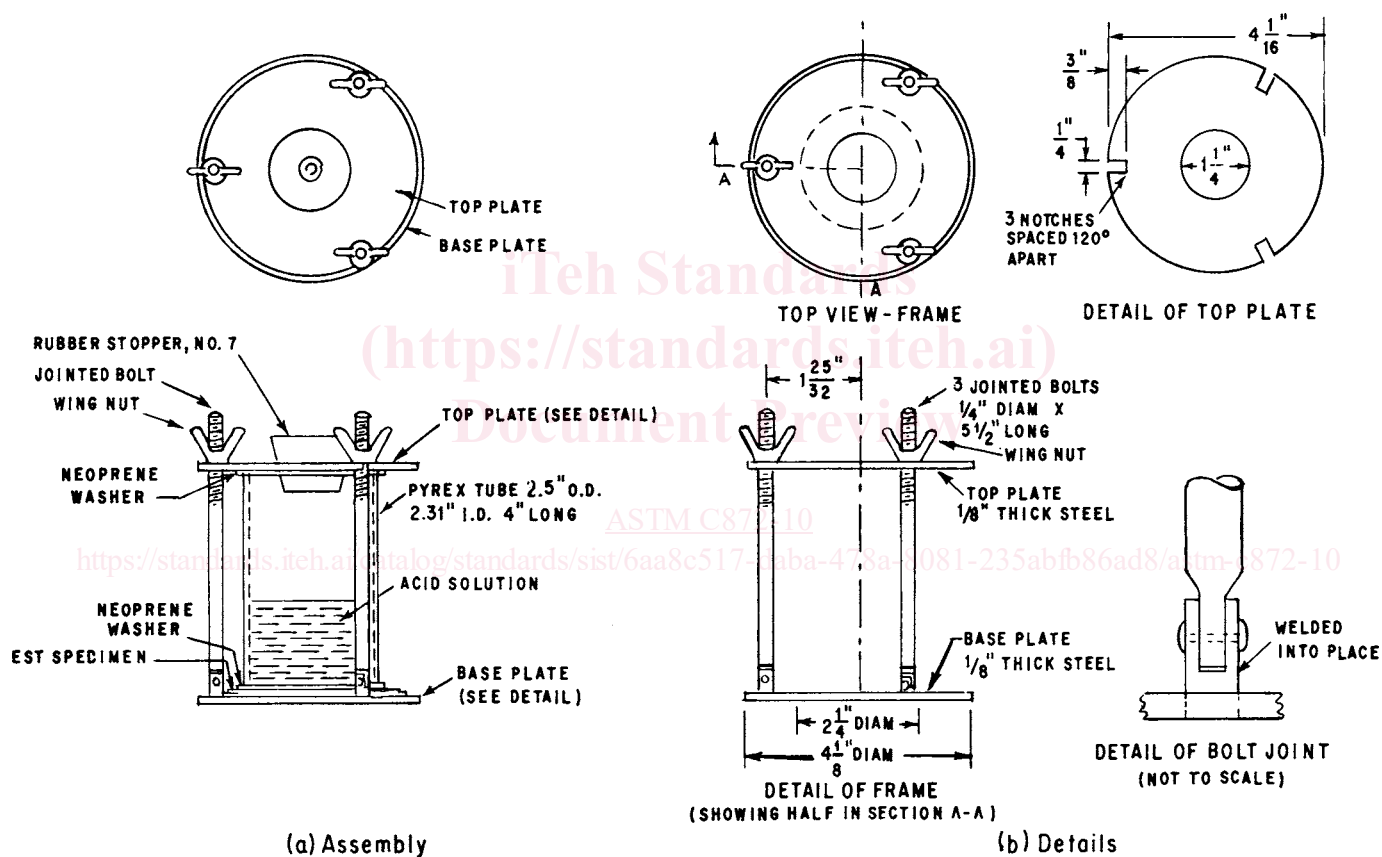

Metric Equivalents for Apparatus Dimensions (Fig. 1)

in.	mm
1/8	3.2
1/4	6.4
3/8	9.5
1/4	31.8
1 25/32	45.2
2 1/4	57.2
2.31	58.7
2.5	63.5
4	101.6
4 1/16	103.2
4 1/8	104.8
5 1/2	139.7

FIG. 1 Suitable Test Cell