



Designation: ~~D695-08~~ Designation: D695 - 10

Standard Test Method for Compressive Properties of Rigid Plastics¹

This standard is issued under the fixed designation D695; the number immediately following the designation indicates the year of original adoption or, in the case of revision, the year of last revision. A number in parentheses indicates the year of last reapproval. A superscript epsilon (ϵ) indicates an editorial change since the last revision or reapproval.

This standard has been approved for use by agencies of the Department of Defense.

1. Scope*

~~1.1~~ 1.1 This test method covers the determination of the mechanical properties of unreinforced and reinforced rigid plastics, including high-modulus composites, when loaded in compression at relatively low uniform rates of straining or loading. Test specimens of standard shape are employed. This procedure is applicable for a composite modulus up to and including 41,370 MPa (6,000,000 psi).

1.2 The values stated in SI units are to be regarded as the standard. The values in parentheses are for information only.

NOTE 1—For compressive properties of resin-matrix composites reinforced with oriented continuous, discontinuous, or cross-ply reinforcements, tests may be made in accordance with Test Method D3410/D3410M.

1.3 *This standard does not purport to address all of the safety concerns, if any, associated with its use. It is the responsibility of the user of this standard to establish appropriate safety and health practices and determine the applicability of regulatory limitations prior to use.* A specific precautionary statement is given in 13.1.

NOTE 2—This test method is technically equivalent to ~~ISO 604~~ ISO 604.

2. Referenced Documents

2.1 ASTM Standards:²

D618 Practice for Conditioning Plastics for Testing

D638 Test Method for Tensile Properties of Plastics

D883 Terminology Relating to Plastics

D3410/D3410M Test Method for Compressive Properties of Polymer Matrix Composite Materials with Unsupported Gage Section by Shear Loading

D4000 Classification System for Specifying Plastic Materials ~~D4066 Classification System for Nylon Injection and Extrusion Materials (PA)~~

D5947 Test Methods for Physical Dimensions of Solid Plastics Specimens

E4 Practices for Force Verification of Testing Machines

E83 Practice for Verification and Classification of Extensometer Systems

E691 Practice for Conducting an Interlaboratory Study to Determine the Precision of a Test Method

2.2 ISO Standard:³

ISO 604 Plastics—Determination of Compressive Properties

3. Terminology

3.1 General—The definitions of plastics used in this test method are in accordance with Terminology D883 unless otherwise indicated.

3.2 Definitions:

3.2.1 *compressive deformation*—the decrease in length produced in the gage length of the test specimen by a compressive load. It is expressed in units of length.

3.2.2 *compressive strain*—the ratio of compressive deformation to the gage length of the test specimen, that is, the change in length per unit of original length along the longitudinal axis. It is expressed as a dimensionless ratio.

¹ This test method is under the jurisdiction of ASTM Committee D20 on Plastics and is the direct responsibility of Subcommittee D20.10 on Mechanical Properties. Current edition approved Aug. April 1, 2008; 2010. Published September 2008; April 2010. Originally approved in 1942. Last previous edition approved in 2002 2008 as ~~D695-02a~~ D695 - 08. DOI: 10.1520/D0695-108.

² For referenced ASTM standards, visit the ASTM website, www.astm.org, or contact ASTM Customer Service at service@astm.org. For Annual Book of ASTM Standards volume information, refer to the standard's Document Summary page on the ASTM website.

³ Supporting data have been filed at ASTM International Headquarters and may be obtained by requesting Research Report RR:D20-106T.

³ Available from American National Standards Institute (ANSI), 25 W. 43rd St., 4th Floor, New York, NY 10036, http://www.ansi.org.

*A Summary of Changes section appears at the end of this standard.

3.2.3 *compressive strength*—the maximum compressive stress (nominal) carried by a test specimen during a compression test. It may or may not be the compressive stress (nominal) carried by the specimen at the moment of rupture.

3.2.4 *compressive strength at failure (nominal)*—the compressive stress (nominal) sustained at the moment of failure of the test specimen if shattering occurs.

3.2.5 *compressive stress (nominal)*—the compressive load per unit area of minimum original cross section within the gage boundaries, carried by the test specimen at any given moment. It is expressed in force per unit area.

3.2.5.1 *Discussion*—The expression of compressive properties in terms of the minimum original cross section is almost universally used. Under some circumstances the compressive properties have been expressed per unit of prevailing cross section. These properties are called “true” compressive properties.

3.2.6 *compressive stress-strain diagram*—a diagram in which values of compressive stress are plotted as ordinates against corresponding values of compressive strain as abscissas.

3.2.7 *compressive yield point*—the first point on the stress-strain diagram at which an increase in strain occurs without an increase in stress.

3.2.8 *compressive yield strength*—normally the stress at the yield point (see also section 3.2.11).

3.2.9 *crushing load*—the maximum compressive force applied to the specimen, under the conditions of testing, that produces a designated degree of failure.

3.2.10 *modulus of elasticity*—the ratio of stress (nominal) to corresponding strain below the proportional limit of a material. It is expressed in force per unit area based on the average initial cross-sectional area.

3.2.11 *offset compressive yield strength*—the stress at which the stress-strain curve departs from linearity by a specified percent of deformation (offset).

3.2.12 *percent compressive strain*—the compressive deformation of a test specimen expressed as a percent of the original gage length.

3.2.13 *proportional limit*—the greatest stress that a material is capable of sustaining without any deviation from proportionality of stress to strain (Hooke’s law). It is expressed in force per unit area.

3.2.14 *slenderness ratio*—the ratio of the length of a column of uniform cross section to its least radius of gyration. For specimens of uniform rectangular cross section, the radius of gyration is 0.289 times the smaller cross-sectional dimension. For specimens of uniform circular cross section, the radius of gyration is 0.250 times the diameter.

4. Significance and Use

4.1 Compression tests provide information about the compressive properties of plastics when employed under conditions approximating those under which the tests are made.

4.2 Compressive properties include modulus of elasticity, yield stress, deformation beyond yield point, and compressive strength (unless the material merely flattens but does not fracture). Materials possessing a low order of ductility may not exhibit a yield point. In the case of a material that fails in compression by a shattering fracture, the compressive strength has a very definite value. In the case of a material that does not fail in compression by a shattering fracture, the compressive strength is an arbitrary one depending upon the degree of distortion that is regarded as indicating complete failure of the material. Many plastic materials will continue to deform in compression until a flat disk is produced, the compressive stress (nominal) rising steadily in the process, without any well-defined fracture occurring. Compressive strength can have no real meaning in such cases.

4.3 Compression tests provide a standard method of obtaining data for research and development, quality control, acceptance or rejection under specifications, and special purposes. The tests cannot be considered significant for engineering design in applications differing widely from the load-time scale of the standard test. Such applications require additional tests such as impact, creep, and fatigue.

4.4 Before proceeding with this test method, reference should be made to the ASTM specification for the material being tested. Any test specimen preparation, conditioning, dimensions, and testing parameters covered in the materials specification shall take precedence over those mentioned in this test method. If there is no material specification, then the default conditions apply. Table 1 in Classification D4000 lists the ASTM materials standards that currently exist.

5. Apparatus

5.1 *Testing Machine*—Any suitable testing machine capable of control of constant-rate-of-crosshead movement and comprising essentially the following:

5.1.1 *Drive Mechanism*—A drive mechanism for imparting to the movable cross-head member, a uniform, controlled velocity with respect to the base (fixed member), with this velocity to be regulated as specified in Section 9.

5.1.2 *Load Indicator*—A load-indicating mechanism capable of showing the total compressive load carried by the test specimen. The mechanism shall be essentially free from inertia-lag at the specified rate of testing and shall indicate the load with an accuracy of $\pm 1\%$ of the maximum indicated value of the test (load). The accuracy of the testing machine shall be verified at least once a year in accordance with Practices E4.

5.2 *Compressometer*—A suitable instrument for determining the distance between two fixed points on the test specimen at any time during the test. It is desirable that this instrument automatically record this distance (or any change in it) as a function of the load on the test specimen. The instrument shall be essentially free of inertia-lag at the specified rate of loading and shall conform

to the requirements for a Class B-2 extensometer as defined in Practice E83.

NOTE 3—The requirements for extensometers cited herein apply to compressometers as well.

5.3 *Compression Tool*—A compression tool for applying the load to the test specimen. This tool shall be so constructed that loading is axial within 1:1000 and applied through surfaces that are flat within 0.025 mm (0.001 in.) and parallel to each other in a plane normal to the vertical loading axis. Examples of suitable compression tools are shown in Fig. 1 and Fig. 2.

5.4 *Supporting Jig*—A supporting jig for thin specimens is shown in Fig. 3 and Fig. 4.

5.5 *Micrometers*—Suitable micrometers, reading to 0.01 mm or 0.001 in. for measuring the width, thickness, and length of the specimens.

6. Test Specimens

6.1 Unless otherwise specified in the materials specifications, the specimens described in 6.2 and 6.7 shall be used. These specimens may be prepared by machining operations from materials in sheet, plate, rod, tube, or similar form, or they may be prepared by compression or injection molding of the material to be tested. All machining operations shall be done carefully so that smooth surfaces result. Great care shall be taken in machining the ends so that smooth, flat parallel surfaces and sharp, clean edges, to within 0.025 mm (0.001 in.) perpendicular to the long axis of the specimen, result.

6.2 The standard test specimen, except as indicated in 6.3-6.7, shall be in the form of a right cylinder or prism whose length is twice its principal width or diameter. Preferred specimen sizes are 12.7 by 12.7 by 25.4 mm (0.50 by 0.50 by 1 in.) (prism), or 12.7 mm in diameter by 25.4 mm (cylinder). Where elastic modulus and offset yield-stress data are desired, the test specimen shall be of such dimensions that the slenderness ratio is in the range from 11 to 16:1. In this case, preferred specimen sizes are 12.7 by 12.7 by 50.8 mm (0.50 by 0.50 by 2 in.) (prism), or 12.7 mm in diameter by 50.8 mm (cylinder).

6.3 For rod material, the test specimen shall have a diameter equal to the diameter of the rod and a sufficient length to allow a specimen slenderness ratio in the range from 11 to 16:1.

6.4 When testing tubes, the test specimen shall have a diameter equal to the diameter of the tube and a length of 25.4 mm (1 in.) (Note 4). For crushing-load determinations (at right angles to the longitudinal axis), the specimen size shall be the same, with the diameter becoming the height.

NOTE 4—This specimen can be used for tubes with a wall thickness of 1 mm (0.039 in.) or over, to inside diameters of 6.4 mm (0.25 in.) or over, and to outside diameters of 50.8 mm (2.0 in.) or less.

6.5 Where it is desired to test conventional high-pressure laminates in the form of sheets, the thickness of which is less than 25.4 mm (1 in.), a pile-up of sheets 25.4 mm square, with a sufficient number of layers to produce a height of at least 25.4 mm, may be used.

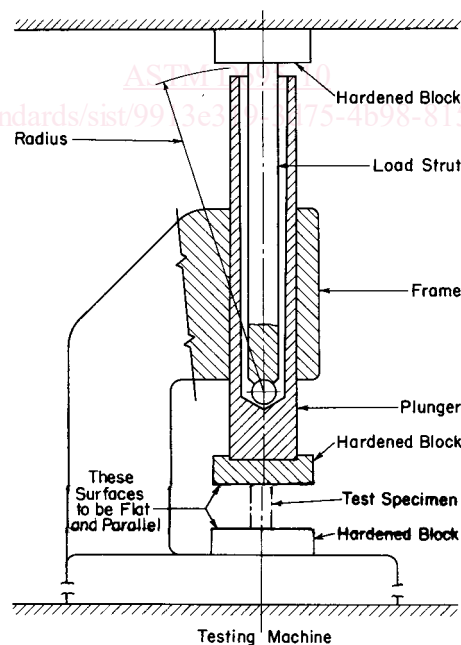

NOTE 1—Devices similar to the one illustrated have been successfully used in a number of different laboratories. Details of the device developed at the National Institute for Standards and Technology are given in the paper by Aitchinson, C. S., and Miller, J. A., "A Subpress for Compressive Tests," National Advisory Committee for Aeronautics, Technical Note No. 912, 1943.

FIG. 1 Subpress for Compression Tests

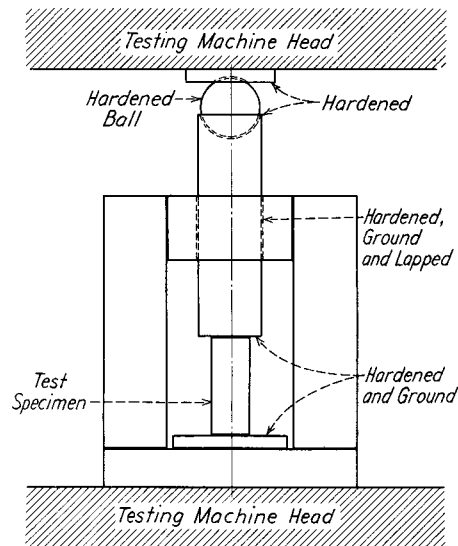

FIG. 2 Compression Tool

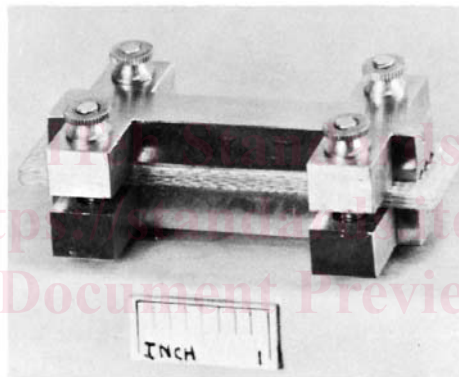

FIG. 3 Support Jig for Thin Specimen

6.6 When testing material that may be suspected of anisotropy, duplicate sets of test specimens shall be prepared having their long axis respectively parallel with and normal to the suspected direction of anisotropy.

6.7 *Reinforced Plastics, Including High-Strength Composites and Highly Orthotropic Laminates*—The following specimens shall be used for reinforced materials, or for other materials when necessary to comply with the slenderness ratio requirements or to permit attachment of a deformation-measuring device.

6.7.1 For materials 3.2 mm (1/8 in.) and over in thickness, a specimen shall consist of a prism having a cross section of 12.7 mm (1/2 in.) by the thickness of the material and a length such that the slenderness ratio is in the range from 11 to 16:1 (Note 5).

6.7.2 For materials under 3.2 mm (1/8 in.) thick, or where elastic modulus testing is required and the slenderness ratio does not provide for enough length for attachment of a compressometer or similar device, a specimen conforming to that shown in Fig. 5 shall be used. The supporting jig shown in Fig. 3 and Fig. 4 shall be used to support the specimen during testing (Note 6).

NOTE 5—If failure for materials in the thickness range of 3.2 mm (1/8 in.) is by delamination rather than by the desirable shear plane fracture, the material may be tested in accordance with 6.7.2.

NOTE 6—Round-robin tests have established that relatively satisfactory measurements of modulus of elasticity may be obtained by applying a compressometer to the edges of the jig-supported specimen.

6.8 When testing syntactic foam, the standard test specimen shall be in the form of a right cylinder 25.4 mm (1 in.) in diameter by 50.8 mm (2 in.) in length.

7. Conditioning

7.1 *Conditioning*—Condition the test specimens at $23 \pm 2^\circ\text{C}$ ($73.4 \pm 3.6^\circ\text{F}$) and $50 \pm 10\%$ relative humidity for not less than 40 h prior to test in accordance with Procedure A of Practice D618 unless otherwise specified by contract or relevant ASTM material specification. Reference pre-test conditioning, to settle disagreements, shall apply tolerances of $\pm 1^\circ\text{C}$ (1.8°F) and $\pm 2\%$ relative humidity.

7.1.1 Note that for some hygroscopic materials, such as nylons, the material specifications (for example, Classification System D4066) call for testing “dry as-molded specimens.” Such requirements take precedence over the above routine preconditioning to

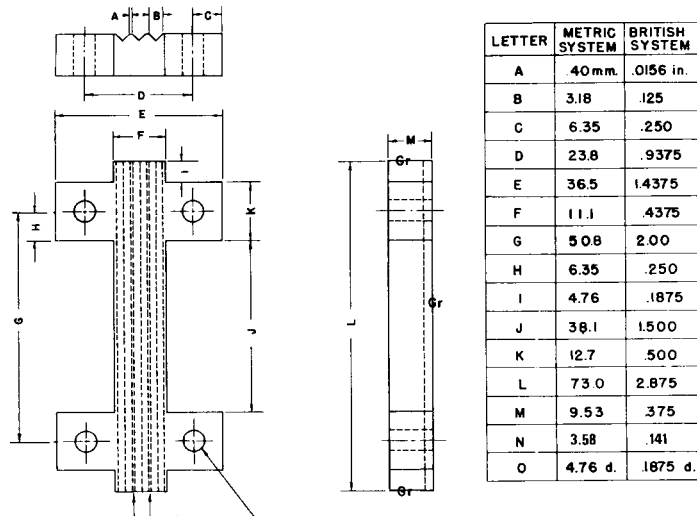

NOTE 1—Cold rolled steel.
 NOTE 2—Furnished four steel machine screws and nuts, round head, slotted, length 31.75 mm (1¼ in.).
 NOTE 3—Grind surfaces denoted “Gr.”

FIG. 4 Support Jig, Details

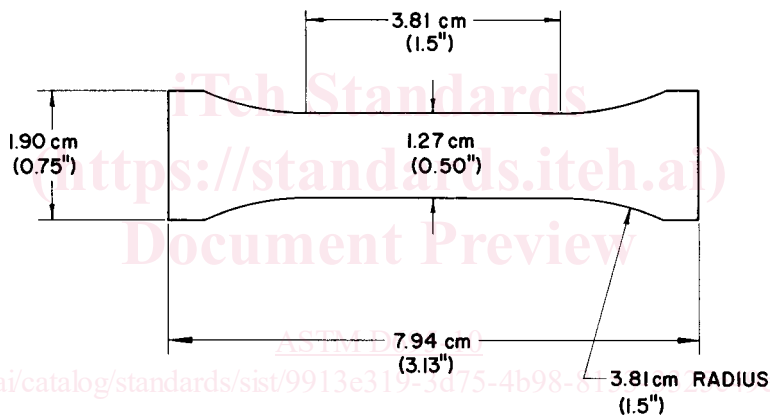

FIG. 5 Compression Test Specimen for Materials Less than 3.2 mm Thick

50% RH and require sealing the specimens in water vapor-impermeable containers as soon as molded and not removing them until ready for testing.

7.2 unless otherwise specified by contract or relevant ASTM material specification. Conditioning time is specified as a minimum. Temperature and humidity tolerances shall be in accordance with Section 7 of Practice D618 unless specified differently by contract or material specification.

7.2 Test Conditions—Conduct the tests at $23 \pm 2^\circ\text{C}$ ($73.4 \pm 3.6^\circ\text{F}$) and $50 \pm 10\%$ relative humidity unless otherwise specified by contract or the relevant ASTM material specification. Reference testing conditions, to settle disagreements, shall apply tolerances of $\pm 1^\circ\text{C}$ (1.8°F) and $\pm 2\%$ relative humidity. Conduct the tests at the same temperature and humidity used for conditioning with tolerances in accordance with Section 7 of Practice D618 unless otherwise specified by contract or the relevant ASTM material specification.

8. Number of Test Specimens

- 8.1 At least five specimens shall be tested for each sample in the case of isotropic materials.
- 8.2 Ten specimens, five normal to and five parallel with the principal axis of anisotropy, shall be tested for each sample in the case of anisotropic materials.
- 8.3 Specimens that break at some obvious flaw shall be discarded and retests made, unless such flaws constitute a variable, the effect of which it is desired to study.

9. Speed of Testing

9.1 Speed of testing shall be the relative rate of motion of the grips or test fixtures during the test. Rate of motion of the driven grip or fixture when the machine is running idle may be used if it can be shown that the resulting speed of testing is within the limits of variation allowed.

9.2 The standard speed of testing shall be 1.3 ± 0.3 mm (0.050 ± 0.010 in./min), except as noted in 10.5.4.

10. Procedure

10.1 Measure the width and thickness of the specimen to the nearest 0.01 mm (0.001 in.) at several points along its length. Calculate and record the minimum value of the cross-sectional area. Measure the length of the specimen and record the value.

10.2 Place the test specimen between the surfaces of the compression tool, taking care to align the center line of its long axis with the center line of the plunger and to ensure that the ends of the specimen are parallel with the surface of the compression tool. Adjust the crosshead of the testing machine until it just contacts the top of the compression tool plunger.

NOTE 7—The compression tool may not be necessary for testing of lower modulus (for example, 700 MPa to 3500 MPa (100,000 psi to 500,000 psi)) material if the loading surfaces are maintained smooth, flat, and parallel to the extent that buckling is not incurred.

10.3 Place thin specimens in the jig (Fig. 3 and Fig. 4) so that they are flush with the base and centered (Note 8). The nuts or screws on the jig shall be finger tight (Note 9). Place the assembly in the compression tool as described in 5.3.

NOTE 8—A round-robin test, designed to assess the influence of specimen positioning in the supporting jig (that is, flush versus centered mounting), showed no significant effect on compressive strength due to this variable. However, flush mounting of the specimen with the base of the jig is specified for convenience and ease of mounting.⁴

NOTE 9—A round-robin test on the effect of lateral pressure at the supporting jig has established that reproducible data can be obtained with the tightness of the jig controlled as indicated.

10.4 If only compressive strength or compressive yield strength, or both, are desired, proceed as follows:

10.4.1 Set the speed control at 1.3 mm/min (0.050 in./min) and start the machine.

10.4.2 Record the maximum load carried by the specimen during the test (usually this will be the load at the moment of rupture).

10.5 If stress-strain data are desired, proceed as follows:

10.5.1 Attach compressometer.

10.5.2 Set the speed control at 1.3 mm/min (0.050 in./min) and start the machine.

10.5.3 Record loads and corresponding compressive strain at appropriate intervals of strain or, if the test machine is equipped with an automatic recording device, record the complete load-deformation curve.

10.5.4 After the yield point has been reached, it may be desirable to increase the speed from 5 to 6 mm/min (0.20 to 0.25 in./min) and allow the machine to run at this speed until the specimen breaks. This may be done only with relatively ductile materials and on a machine with a weighing system with response rapid enough to produce accurate results.

11. Calculation

11.1 *Compressive Strength*—Calculate the compressive strength by dividing the maximum compressive load carried by the specimen during the test by the original minimum cross-sectional area of the specimen. Express the result in megapascals or pounds-force per square inch and report to three significant figures.

11.2 *Compressive Yield Strength*—Calculate the compressive yield strength by dividing the load carried by the specimen at the yield point by the original minimum cross-sectional area of the specimen. Express the result in megapascals or pounds-force per square inch and report to three significant figures.

11.3 *Offset Yield Strength*—Calculate the offset yield strength by the method referred to in 3.2.11.

11.4 *Modulus of Elasticity*—Calculate the modulus of elasticity by drawing a tangent to the initial linear portion of the load deformation curve, selecting any point on this straight line portion, and dividing the compressive stress represented by this point by the corresponding strain, measure from the point where the extended tangent line intersects the strain-axis. Express the result in gigapascals or pounds-force per square inch and report to three significant figures (see Annex A1).

11.5 For each series of tests, calculate to three significant figures the arithmetic mean of all values obtained and report as the “average value” for the particular property in question.

11.6 Calculate the standard deviation (estimated) as follows and report to two significant figures:

$$(1) \quad s = (\sum X^2 - n\bar{X}^2)/(n - 1)$$

where:

s = estimated standard deviation,

X = value of single observation,

n = number of observations, and

\bar{X} = arithmetic mean of the set of observations.

NOTE 10—The method for determining the offset compressive yield strength is similar to that described in the Annex of Test Method D638.

12. Report

12.1 Report the following information:

⁴ Supporting data have been filed at ASTM International Headquarters and may be obtained by requesting Research Report RR:D20-1061.