Goriva za motorna vozila - Metilni estri maščobnih kislin (FAME) goriv in mešanic z dizelskim gorivom - Določevanje oksidacijske stabilnosti z metodo pospešene oksidacije pri 120 °C

Automotive fuels - Blends of Fatty acid methyl ester (FAME) with diesel fuel - Determination of oxidation stability by rapidly accelerated oxidation method at 120 °C

Kraftstoffe für Kraftfahrzeuge - Mischungen von Fettsäure-Methylestern (FAME) mit Dieselmotorkraftstoff - Bestimmung der Oxidationsstabilität mittels beschleunigtem Oxidationsverfahren bei 120 °C

Carburants pour automobiles - Mélanges d'esters méthyliques d'acides gras (EMAG) avec du gazole - Détermination de la stabilité à l'oxydation par méthode d'oxydation plus accélérée à 120 °C

<https://standards.iteh.ai/catalog/standards/sist/96e2030c-a3ee-4982-bce7-9ec3ce6375bc/osist-pren-16568-2022>

Ta slovenski standard je istoveten z: prEN 16568

ICS:

75.160.20 Tekoča goriva Liquid fuels

oSIST prEN 16568:2022 en

**iTeh STANDARD
PREVIEW
(standards.iteh.ai)**

[oSIST prEN 16568:2022](https://standards.iteh.ai/catalog/standards/sist/96e2030c-a3ee-4982-bce7-9ec3ce6375bc/osist-pren-16568-2022)

<https://standards.iteh.ai/catalog/standards/sist/96e2030c-a3ee-4982-bce7-9ec3ce6375bc/osist-pren-16568-2022>

EUROPEAN STANDARD
NORME EUROPÉENNE
EUROPÄISCHE NORM

DRAFT
prEN 16568

June 2022

ICS 75.160.20

Will supersede EN 16568:2014

English Version

**Automotive fuels - Blends of Fatty acid methyl ester
(FAME) with diesel fuel - Determination of oxidation
stability by rapidly accelerated oxidation method at 120 °C**

Carburants pour automobiles - Mélanges d'esters
méthylliques d'acides gras (EMAG) avec du gazole -
Détermination de la stabilité à l'oxydation par méthode
d'oxydation plus accélérée à 120 °C

Kraftstoffe für Kraftfahrzeuge - Mischungen von
Fettsäure-Methylestern (FAME) mit Dieselkraftstoff -
Bestimmung der Oxidationsstabilität mittels
beschleunigterem Oxidationsverfahren bei 120 °C

This draft European Standard is submitted to CEN members for enquiry. It has been drawn up by the Technical Committee CEN/TC 19.

If this draft becomes a European Standard, CEN members are bound to comply with the CEN/CENELEC Internal Regulations which stipulate the conditions for giving this European Standard the status of a national standard without any alteration.

This draft European Standard was established by CEN in three official versions (English, French, German). A version in any other language made by translation under the responsibility of a CEN member into its own language and notified to the CEN-CENELEC Management Centre has the same status as the official versions.

CEN members are the national standards bodies of Austria, Belgium, Bulgaria, Croatia, Cyprus, Czech Republic, Denmark, Estonia, Finland, France, Germany, Greece, Hungary, Iceland, Ireland, Italy, Latvia, Lithuania, Luxembourg, Malta, Netherlands, Norway, Poland, Portugal, Republic of North Macedonia, Romania, Serbia, Slovakia, Slovenia, Spain, Sweden, Switzerland, Turkey and United Kingdom.

Recipients of this draft are invited to submit, with their comments, notification of any relevant patent rights of which they are aware and to provide supporting documentation.

Warning : This document is not a European Standard. It is distributed for review and comments. It is subject to change without notice and shall not be referred to as a European Standard.



EUROPEAN COMMITTEE FOR STANDARDIZATION
COMITÉ EUROPÉEN DE NORMALISATION
EUROPÄISCHES KOMITEE FÜR NORMUNG

CEN-CENELEC Management Centre: Rue de la Science 23, B-1040 Brussels

Contents

	Page
European foreword.....	3
Introduction	4
1 Scope	5
2 Normative references.....	5
3 Terms and definitions	5
4 Principle	5
5 Chemicals	6
6 Apparatus.....	6
7 Sampling.....	9
8 Preparation of measurement	9
8.1 Preparation of test sample	9
8.2 Preparation of the apparatus	9
8.2.1 Cleaning procedure	9
8.2.2 Temperature correction.....	10
9 Measurement.....	10
10 Calculation and evaluation	14
10.1 Automatic evaluation.....	14
10.2 Manual evaluation	15
11 Expression of results.....	15
12 Precision.....	15
12.1 General.....	15
12.2 Repeatability, r	15
12.3 Reproducibility, R	15
13 Test report.....	16
Bibliography.....	17

Iteh STANDARD
PREVIEW
(standards.iteh.ai)

[oSIST prEN 16568:2022](https://standards.iteh.ai/catalog/standards/sist/96c2030c-a3ee-4982-bce7-9ec3ce6375bc/osist-pren-16568-2022)

<https://standards.iteh.ai/catalog/standards/sist/96c2030c-a3ee-4982-bce7-9ec3ce6375bc/osist-pren-16568-2022>

European foreword

This document (prEN 16568:2022) has been prepared by Technical Committee CEN/TC 19 “Gaseous and liquid fuels, lubricants and related products of petroleum, synthetic and biological origin”, the secretariat of which is held by NEN.

This document is currently submitted to the CEN Enquiry.

This document will supersede EN 16568:2014.

In comparison with the previous edition, the following technical modifications have been made:

- Alignment with the revised EN 14112.

iTeh STANDARD PREVIEW (standards.iteh.ai)

[oSIST prEN 16568:2022](https://standards.iteh.ai/catalog/standards/sist/96e2030c-a3ee-4982-bce7-9ec3ce6375bc/osist-pren-16568-2022)

<https://standards.iteh.ai/catalog/standards/sist/96e2030c-a3ee-4982-bce7-9ec3ce6375bc/osist-pren-16568-2022>

Introduction

This document is based on EN 15751 [1], which was specifically developed for the determination of oxidation stability of fatty acid methyl ester (FAME) and blended petroleum-based diesel fuels. The oxidation stability is assessed by determining the induction period of the fuel. The induction period is a measure for the ageing reserve of the fuel.

The first version of EN 15751 was developed under CEN/TC 19 for a test temperature of 110 °C in order to stay directly comparable to EN 14112 [2] which is used to determine the oxidation stability of pure FAME. The stability of diesel/FAME blends is generally higher compared to pure FAME, thus leading to long measuring times. In order to better accommodate the needs of laboratories, the idea was raised to increase the reaction temperature to 120 °C. Degradation of the ageing reserve of the fuel follows the Arrhenius law. By increasing the temperature by 10 °C, the reaction rate is doubled, cutting in half the induction period.

The modifications to EN 15751, as given in this document, allow the application of this test method for oxidation stability for diesel/FAME blends containing 2 % (V/V) of FAME at minimum. This test method is not applicable to pure FAME. Pure FAME was not included in the scope because of reduced ability to differentiate between different qualities when the induction period is reduced by 50 %.

The temperature increase required a new validation for diesel/FAME blends. Blends with up to 50 % (V/V) of FAME were selected for this document in order for this document to also cover high FAME blends, which are currently being discussed for automotive use.

**ITEH STANDARD
PREVIEW
(standards.iteh.ai)**

[oSIST prEN 16568:2022](https://standards.iteh.ai/catalog/standards/sist/96e2030c-a3ee-4982-bce7-9ec3ce6375bc/osist-pren-16568-2022)

<https://standards.iteh.ai/catalog/standards/sist/96e2030c-a3ee-4982-bce7-9ec3ce6375bc/osist-pren-16568-2022>

1 Scope

This document specifies a test method for the determination of the oxidation stability at 120 °C of fuels for diesel engines, by means of measuring the induction period of the fuel up to 20 h. The method is applicable to blends of FAME with petroleum-based diesel having a FAME content in the range between 2 % (V/V) and 50 % (V/V).

NOTE 1 An almost identical test method for oxidation stability at 110 °C is described in EN 15751 [1], which applies to pure FAME and diesel/FAME blends containing 2 % (V/V) of FAME at minimum. Other alternative test methods for the determination of the oxidation stability of distillate fuels are described in CEN/TR 17225 [3].

NOTE 2 The precision of this method was determined using samples with a maximum induction period of approximately 20 h. Higher induction periods are not covered by the precision statement; however, experience from EN 15751 indicates sufficient precision up to 48 h.

NOTE 3 The presence of cetane improver can reduce the oxidation stability determined by this test method. Limited studies with 2-ethyl hexyl nitrate (EHN) indicated that the stability is reduced to an extent which is within the reproducibility of the test method.

NOTE 4 For the purposes of this document, the term “% (V/V)” is used to represent the volume fraction.

2 Normative references

The following documents are referred to in the text in such a way that some or all of their content constitutes requirements of this document. For dated references, only the edition cited applies. For undated references, the latest edition of the referenced document (including any amendments) applies.

EN ISO 3170, *Petroleum liquids - Manual sampling (ISO 3170)*

EN ISO 3171, *Petroleum liquids - Automatic pipeline sampling (ISO 3171)*

3 Terms and definitions

For the purposes of this document, the following terms and definitions apply.

ISO and IEC maintain terminological databases for use in standardization at the following addresses:

— IEC Electropedia: available at <https://www.electropedia.org/>

— ISO Online browsing platform: available at <https://www.iso.org/obp>

3.1

induction period

time which passes between the moment when the measurement is started and the moment when the formation of oxidation products begins to increase rapidly

3.2

oxidation stability

induction period determined according to the procedure specified in this document, expressed in hours

4 Principle

A stream of purified air is passed through the sample which has been heated to the specified, elevated temperature. Volatile compounds are formed during the oxidation process. They are passed, together with the air, into a measurement cell containing demineralized or distilled water and equipped with a conductivity electrode. The electrode is connected to a measuring and recording device. It indicates the

prEN 16568:2022 (E)

end of the induction period by rapid increase of the conductivity due to the dissociation of volatile carboxylic acids produced during the oxidation process and absorbed in the water. For more details on the background of the method see CEN/TR 17225 [3].

5 Chemicals

5.1 Distilled or demineralized water, according to EN ISO 3696.

5.2 Alkaline laboratory glass cleaning solution.

5.3 Ternary solvent mixture, 1: 1: 1 (by volume), consisting of methanol/toluene/acetone, each of recognized analytical grade.

5.4 2-Propanol, of recognized analytical grade.

5.5 Thermo-stable oil, e.g. silicon oil.

6 Apparatus

6.1 Device for the determination of oxidation stability, comprising of the following parts (see Figure 1 and Figure 2):

NOTE An instrument for determining the oxidation stability is commercially available under the trade name Rancimat® (model 743 or higher) or OSI® Instrument.¹

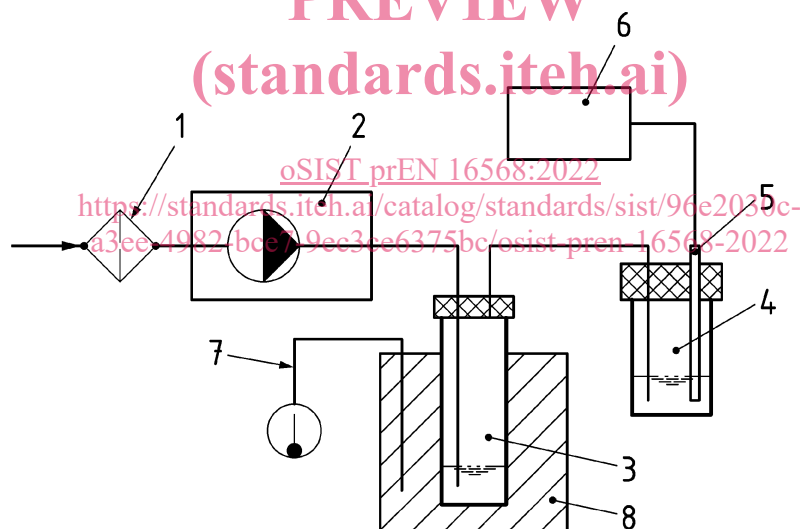

Key

- | | | | |
|---|--|---|---|
| 1 | air filter (6.1.1) | 5 | electrode (6.1.5) |
| 2 | gas membrane pump with flow rate control (6.1.2) | 6 | measuring and recording apparatus (6.1.6) |
| 3 | reaction vessel (6.1.3) | 7 | contact thermometer or Pt 100 element (6.1.7) |
| 4 | measurement cell (6.1.4) | 8 | heating block (6.1.8) |

¹ Rancimat® is a trademark of Metrohm AG, Herisau, Switzerland and OSI® Instrument is a trademark from Omnion Inc., Rockland, Massachusetts, USA. This information is given for the convenience of users of this document and does not constitute an endorsement by CEN of the products named. Equivalent devices may be used if they can be shown to lead to the same results, at the same or better precision.

Figure 1 — Apparatus

6.1.1 Air filter, comprising a tube fitted with filter paper at the ends and filled with a molecular sieve (6.6), connected to the suction end of a pump.

6.1.2 Gas membrane pump, with an adjustable flow rate of $(10 \pm 1,0)$ l/h.

6.1.3 Reaction vessel, of borosilicate glass, provided with a sealing cap. The sealing cap shall be fitted with an air inlet and outlet tube.

The length of the reaction vessel depends on the measuring equipment and shall exceed the depth of the oven by at least 130 mm, in order to reduce evaporation losses to a minimum by condensing volatile fuel components at the cold vessel walls outside the oven.

EXAMPLE Total length of the test tube for the Metrohm Rancimat 743 L = 250 mm, for the Omnion OSI Instrument L = 300 mm.

6.1.4 Closed measurement cell, of approximately 150 ml capacity, with an air inlet tube extending to the bottom inside of the vessel. The cell shall have ventilation holes at the top.

6.1.5 Electrodes, for measuring the conductivity within a range from $0 \mu\text{S}/\text{cm}$ to $300 \mu\text{S}/\text{cm}$ aligned with the dimensions of the measurement cell (6.1.4).

6.1.6 Measuring and recording apparatus, comprising of an amplifier and a recorder registering the signal of each of the electrodes (6.1.5).

6.1.7 Contact thermometer graduated in $0,1^\circ\text{C}$ or Pt 100 element, to measure the block temperature, with attachments for relay connection and an adjustable heating element; temperature scale 0°C to 150°C .

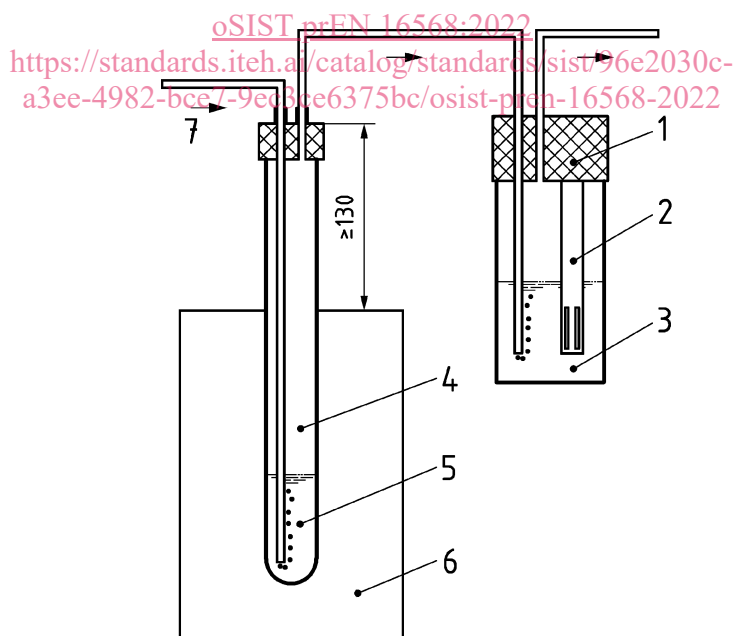

Key

- | | | | |
|---|-------------------------------------|---|-----------------------|
| 1 | measurement cell (6.1.4) | 5 | sample |
| 2 | electrode (6.1.5) | 6 | heating block (6.1.8) |
| 3 | distilled/demineralized water (5.1) | 7 | air inlet |
| 4 | reaction vessel (6.1.3) | | |

Figure 2 — Heating block, reaction vessel and measurement cell

- 6.1.8 Heating block**, made of cast aluminium, adjustable to a temperature up to $(150 \pm 0,1)$ °C. The block shall be provided with holes for the reaction vessels (6.1.3), and an aperture for the contact thermometer (6.1.7).
- 6.1.9 Standard laboratory PC, equipped with software for measurement and data evaluation**, e.g. as provided by the producer of the measuring and recording apparatus.
- 6.2 Certified and calibrated thermometer or Pt 100 element**, with a temperature range up to 150 °C, graduated in 0,1 °C.
- 6.3 Measuring pipettes and/or measuring cylinders.**
- 6.4 Oven**, capable of being maintained up to (150 ± 3) °C.
- 6.5 Connecting hoses**, flexible and made of inert material [polytetrafluoroethylene (PTFE) or silicone].
- 6.6 Molecular sieve**, with moisture indicator, pore size 0,3 nm, dried in an oven set at 150 °C and cooled down to room temperature in a desiccator before use.
- 6.7 Balance**, capable of weighing with an accuracy of $\pm 0,1$ g or less.

iTeh STANDARD
PREVIEW
(standards.iteh.ai)

<https://standards.iteh.ai/catalog/standards/sist/96e2030c-a3ee-4982-bce7-9ec3ce6375bc/osist-pren-16568-2022>