**Mechanical vibration — Rotor
balancing —**

**Part 1:
Introduction**

Vibrations mécaniques — Équilibrage des rotors —

Partie 1: Introduction

<https://standards.iteh.ai>

Document Preview

[ISO 21940-1:2019](https://standards.iteh.ai/catalog/standards/iso/e888a1da-da20-4c0b-a555-3d1f4a78f3f0/iso-21940-1-2019)

<https://standards.iteh.ai/catalog/standards/iso/e888a1da-da20-4c0b-a555-3d1f4a78f3f0/iso-21940-1-2019>



iTeh Standards
(<https://standards.iteh.ai>)
Document Preview

[ISO 21940-1:2019](https://standards.iteh.ai/catalog/standards/iso/e888a1da-da20-4c0b-a555-3d1f4a78f3f0/iso-21940-1-2019)

<https://standards.iteh.ai/catalog/standards/iso/e888a1da-da20-4c0b-a555-3d1f4a78f3f0/iso-21940-1-2019>



COPYRIGHT PROTECTED DOCUMENT

© ISO 2019

All rights reserved. Unless otherwise specified, or required in the context of its implementation, no part of this publication may be reproduced or utilized otherwise in any form or by any means, electronic or mechanical, including photocopying, or posting on the internet or an intranet, without prior written permission. Permission can be requested from either ISO at the address below or ISO's member body in the country of the requester.

ISO copyright office
CP 401 • Ch. de Blandonnet 8
CH-1214 Vernier, Geneva
Phone: +41 22 749 01 11
Fax: +41 22 749 09 47
Email: copyright@iso.org
Website: www.iso.org

Published in Switzerland

Contents

Page

Foreword	v
Introduction	vi
1 Scope	1
2 Normative references	1
3 Terms and definitions	1
4 Fundamentals of balancing	1
4.1 General.....	1
4.2 Unbalance of a single disc.....	2
4.3 Unbalance distribution.....	4
4.4 Unbalance representation.....	4
5 Factors to consider when balancing	5
5.1 General.....	5
5.2 Rotors with rigid behaviour.....	5
5.3 Rotors with flexible behaviour.....	6
5.3.1 General.....	6
5.3.2 Shaft-elastic behaviour.....	6
5.3.3 Component-elastic behaviour.....	7
5.3.4 Settling behaviour.....	7
5.4 Examples of rotor behaviours.....	7
6 Selection of a balancing procedure	8
7 Unbalance tolerances	9
7.1 General.....	9
7.2 Permissible residual unbalance.....	9
7.2.1 General.....	9
7.2.2 Permissible residual unbalance for rotors with rigid behaviour.....	9
7.2.3 Permissible residual unbalance for rotors with flexible behaviour.....	9
7.3 Vibration limits.....	10
7.4 Influence of modes above service speed.....	10
7.5 Factors influencing balancing procedures.....	11
7.5.1 General.....	11
7.5.2 Tolerances.....	11
7.5.3 Speed and support conditions.....	12
7.5.4 Initial unbalance.....	12
8 Selection of a balancing machine	12
8.1 General.....	12
8.2 Special requirements.....	13
9 International Standards on balancing	13
9.1 General.....	13
9.2 Vocabulary.....	14
9.2.1 ISO 21940-2 — Balancing vocabulary.....	14
9.2.2 ISO 2041 — Vibration and shock vocabulary.....	14
9.3 Balancing procedures and tolerances.....	14
9.3.1 General.....	14
9.3.2 ISO 21940-11 — Procedures and tolerances for rotors with rigid behaviour.....	14
9.3.3 ISO 21940-12 — Procedures and tolerances for rotors with flexible behaviour.....	14
9.3.4 ISO 21940-13 — Criteria and safeguards for the <i>in-situ</i> balancing of medium and large rotors.....	14
9.3.5 ISO 21940-14 — Procedures for addressing balancing errors.....	15
9.4 Balancing machines.....	15
9.4.1 ISO 21940-21 — Description and evaluation of balancing machines.....	15

ISO 21940-1:2019(E)

9.4.2	ISO 21940-23 — Enclosures and other protective measures for the measuring station of balancing machines	15
9.5	Machine design for balancing.....	16
9.5.1	ISO 21940-31 — Susceptibility and sensitivity of machines to unbalance.....	16
9.5.2	ISO 21940-32 — Shaft and fitment key convention.....	16
Annex A (informative) Mathematical and graphical representation of unbalance		17
Annex B (informative) Examples of different rotor behaviours as indicated on a typical hard-bearing balancing machine		24
Bibliography		30

iTeh Standards (<https://standards.iteh.ai>) Document Preview

[ISO 21940-1:2019](https://standards.iteh.ai/catalog/standards/iso/e888a1da-da20-4c0b-a555-3d1f4a78f3f0/iso-21940-1-2019)

<https://standards.iteh.ai/catalog/standards/iso/e888a1da-da20-4c0b-a555-3d1f4a78f3f0/iso-21940-1-2019>

Foreword

ISO (the International Organization for Standardization) is a worldwide federation of national standards bodies (ISO member bodies). The work of preparing International Standards is normally carried out through ISO technical committees. Each member body interested in a subject for which a technical committee has been established has the right to be represented on that committee. International organizations, governmental and non-governmental, in liaison with ISO, also take part in the work. ISO collaborates closely with the International Electrotechnical Commission (IEC) on all matters of electrotechnical standardization.

The procedures used to develop this document and those intended for its further maintenance are described in the ISO/IEC Directives, Part 1. In particular the different approval criteria needed for the different types of ISO documents should be noted. This document was drafted in accordance with the editorial rules of the ISO/IEC Directives, Part 2 (see www.iso.org/directives).

Attention is drawn to the possibility that some of the elements of this document may be the subject of patent rights. ISO shall not be held responsible for identifying any or all such patent rights. Details of any patent rights identified during the development of the document will be in the Introduction and/or on the ISO list of patent declarations received (see www.iso.org/patents).

Any trade name used in this document is information given for the convenience of users and does not constitute an endorsement.

For an explanation on the voluntary nature of standards, the meaning of ISO specific terms and expressions related to conformity assessment, as well as information about ISO's adherence to the World Trade Organization (WTO) principles in the Technical Barriers to Trade (TBT) see the following URL: www.iso.org/iso/foreword.html.

This document was prepared by Technical Committee ISO/TC 108, *Mechanical vibration, shock and condition monitoring*, Subcommittee SC 2, *Measurement and evaluation of mechanical vibration and shock as applied to machines, vehicles and structures*.

This first edition of ISO 21940-1 cancels and replaces ISO 19499:2007, which has been technically revised. The main changes are as follows:

- reference made to all International Standards in the ISO 21940 series;
- deletion of former Table 2 "Guidelines for balancing procedures";
- deletion of former Annex C "How to determine rotor flexibility based on an estimation from its geometric design".

A list of all parts in the ISO 21940 series can be found on the ISO website.

Any feedback or questions on this document should be directed to the user's national standards body. A complete listing of these bodies can be found at www.iso.org/members.html.

Introduction

Vibration caused by rotor unbalance is one of the most critical issues in the design and maintenance of rotating machines. It gives rise to dynamic forces which adversely affect both machine and human health and well-being. The purpose of this document is to give guidance on the usage of the other parts of the ISO 21940 series.

Balancing is explained in a general manner, using the specific terms and definitions, to help readers to select the appropriate balancing approach for their application.

iTeh Standards
(<https://standards.itih.ai>)
Document Preview

[ISO 21940-1:2019](https://standards.itih.ai/catalog/standards/iso/e888a1da-da20-4c0b-a555-3d1f4a78f3f0/iso-21940-1-2019)

<https://standards.itih.ai/catalog/standards/iso/e888a1da-da20-4c0b-a555-3d1f4a78f3f0/iso-21940-1-2019>

Mechanical vibration — Rotor balancing —

Part 1: Introduction

1 Scope

This document provides a general background to balancing technology, as used in the ISO 21940 series, and directs the reader to the appropriate parts of the series that include vocabulary, balancing procedures and tolerances, balancing machines and machine design for balancing.

Individual procedures are not included here as these can be found in the appropriate parts of ISO 21940.

2 Normative references

The following documents are referred to in the text in such a way that some or all of their content constitutes requirements of this document. For dated references, only the edition cited applies. For undated references, the latest edition of the referenced document (including any amendments) applies.

ISO 2041, *Mechanical vibration, shock and condition monitoring — Vocabulary*

ISO 21940-2, *Mechanical vibration — Rotor balancing — Part 2: Vocabulary*

3 Terms and definitions

For the purposes of this document, the terms and definitions given in ISO 2041 and ISO 21940-2 apply.

ISO and IEC maintain terminological databases for use in standardization at the following addresses:

- ISO Online browsing platform: available at <https://www.iso.org/obp/>
- IEC Electropedia: available at <http://www.electropedia.org/>

4 Fundamentals of balancing

4.1 General

Balancing is a procedure by which the mass distribution of a rotor (or part of a rotor or module) is measured and adjusted to ensure that unbalance tolerances are met.

Many factors can cause rotor unbalance, e.g. non-homogenous material, manufacture, assembly, wear during operation, debris or an operational event. It is important to understand that every rotor, even in series production, has a unique individual unbalance distribution.

New rotors are commonly balanced by the manufacturer in balancing machines before installation into their operational environment. Following rework or repair, rotors can be rebalanced in a balancing machine or, if appropriate facilities are not available, the rotor can be balanced *in situ* (for details, see ISO 21940-13). For *in-situ* balancing, the rotor is held in its service bearings and support structure and rotated within its operational drive train.

When rotated, unbalance generates forces that can be directly measured by force gauges mounted on the structures supporting the bearings or indirectly by measuring either the motion of the bearing or the shaft. The unbalance vector can be calculated from these measurements and balancing achieved by

adding, removing or moving correction masses on the rotor. Depending on the balancing task, the mass corrections are performed in one, two or more correction planes.

Inertia forces due to unbalances or correction masses added during the balancing process induce an excitation of the rotor and support system, which is observed as once-per-revolution vibration. Once-per-revolution vibration and vibration at other frequencies can also be excited by other effects, e.g. asymmetric stiffness, magnetic or fluid forces, but it is only the once-per-revolution effects that can be compensated for by balancing. Non-linear systems can also cause frequencies other than at once per revolution to be generated but these are usually a second order effect.

The theory of balancing is widely described in the literature (see e.g. References [11], [12]), and therefore only the basics are presented here to aid the understanding of the terms used in balancing standards and to direct the user towards the appropriate parts of ISO 21940.

4.2 Unbalance of a single disc

The simplest mechanical model of a rotor consists of a single disc supported on two bearings by a massless shaft as shown in [Figure 1](#). An unbalance mass, m_U , on the disc with a radial distance from the shaft axis, r , generates the unbalance vector, \mathbf{U} , whereby $\mathbf{U} = m_U \mathbf{r}$. The unbalance vector \mathbf{U} is expressed in the unit of mass times length, usually kg·m, but for practical reasons, smaller units are generally used, e.g. kg mm, g mm or, for very small unbalances, mg mm.

NOTE Bold font indicates vector quantities.

At a rotational speed n (angular velocity Ω), the unbalance causes a centrifugal force $\mathbf{F} = \mathbf{U} \Omega^2$. When expressing the unbalance, \mathbf{U} , in kg·m, and the angular velocity, Ω , in rad/s, \mathbf{F} is expressed in newtons, N.

(<https://standards.iteh.ai>)
Document Preview

[ISO 21940-1:2019](#)

<https://standards.iteh.ai/catalog/standards/iso/e888a1da-da20-4c0b-a555-3d1f4a78f3f0/iso-21940-1-2019>

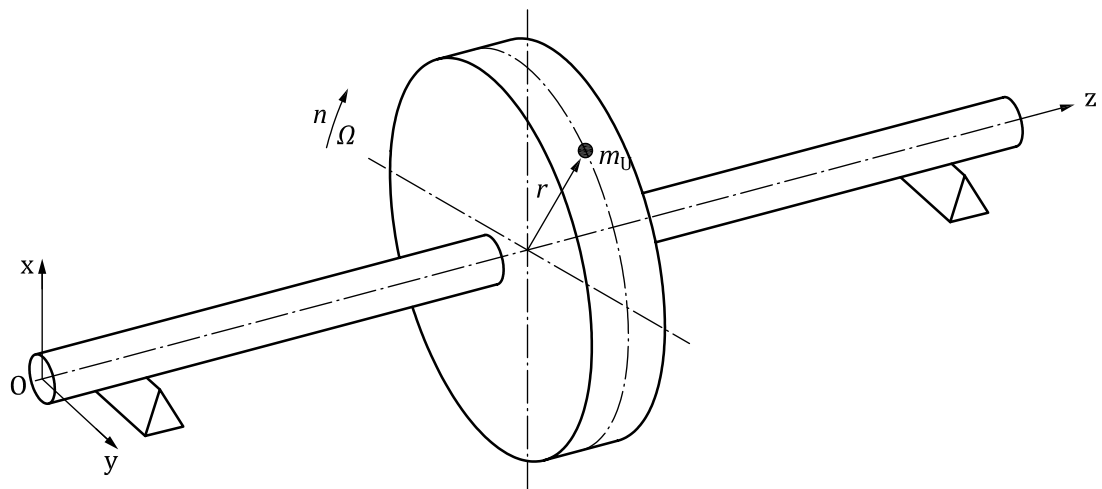

a) Unbalance of a disc as unbalance mass m_U at radius r

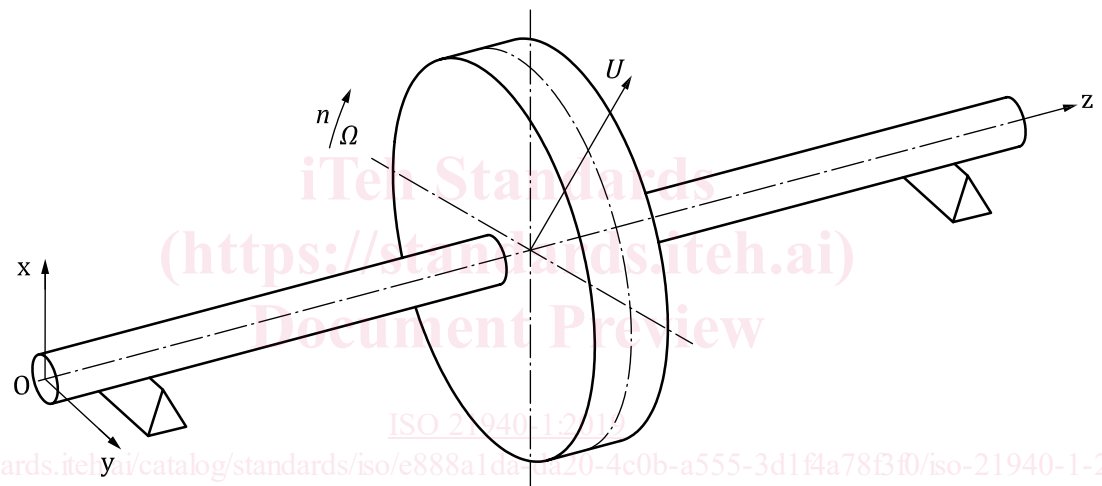

b) Unbalance of a disc as unbalance vector U

Figure 1 — Unbalance of a disc

The unbalance, U , can be expressed as the eccentricity, e , of the disc mass, M , from the shaft axis, given by the expression $U = M e$. See [Figure 2](#).

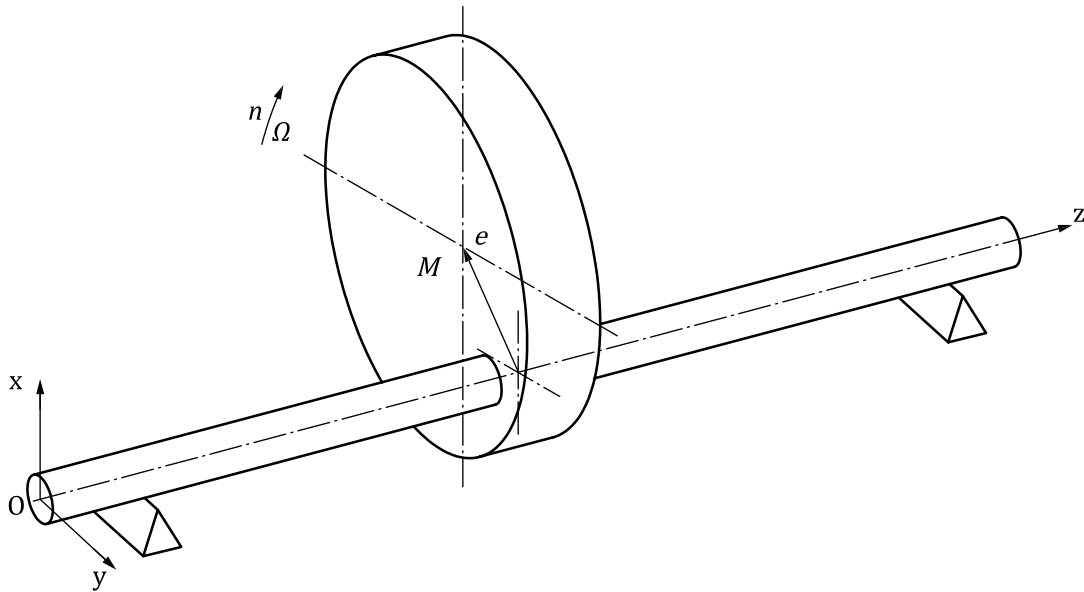

Figure 2 — Unbalance of a disc, expressed as the eccentricity of the mass centre from the shaft axis

4.3 Unbalance distribution

For a general rotor, with a certain axial length, unbalance is made up of an infinite number of unbalance vectors, distributed along the shaft axis. If a lumped-mass model is used to simulate the rotor behaviour, the unbalance can be represented by a finite number of unbalance vectors of different amplitudes and angular directions, as illustrated in Figure 3.

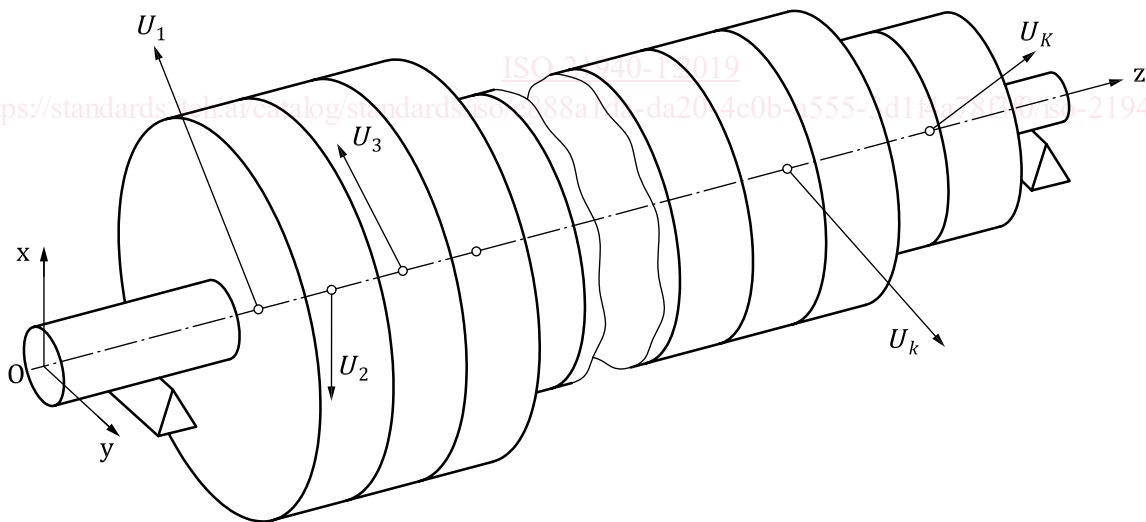

Figure 3 — Unbalance distribution in a rotor modelled as K disc elements perpendicular to the z axis

4.4 Unbalance representation

If all unbalance vectors were corrected in their respective planes, the rotor would be perfectly balanced but, in practice, it is neither possible nor necessary to measure and correct for all the individual

unbalances. Throughout the ISO 21940 series, the following representations are used to specify rotor unbalance:

- a) resultant unbalance U_r , vector sum of all unbalance vectors distributed along the rotor;

NOTE 1 The plane to state the resultant unbalance can be arbitrarily chosen.

NOTE 2 If the plane for the resultant unbalance is the plane of the mass centre, the unbalance is called static unbalance.

- b) resultant moment unbalance P_r , the vector sum of the moments of all the unbalance vectors distributed along the rotor with respect to an arbitrarily selected plane perpendicular to the shaft axis;
- c) resultant equivalent modal unbalance values $U_{ne,r}$, the unbalance distribution which affects each of the n th natural modes of the rotor system.

Mathematical and graphical representations of unbalance are described in [Annex A](#).

NOTE 3 The resultant unbalance [see a)] and resultant moment unbalance [see b)] can be combined. The combination is called “dynamic unbalance” and is represented by two unbalance vectors in two arbitrarily chosen planes perpendicular to the shaft axis.

NOTE 4 The balancing procedures described in the ISO 21940 series assume the rotor system is linear and the modes of vibration are orthogonal. For example, adding 2 g mm mass correction has twice the effect of 1 g mm and the mode shape of one mode is not affected by other modes. Fluid-film bearings, which are often used in high-speed balancing machines, can introduce non-linearities and cross coupling between modes but generally the effects are small and the balancing procedures described in the ISO 21940 series can be adopted.

5 Factors to consider when balancing

5.1 General

For the purpose of balancing, it is normal to refer to rotors as rigid or flexible, i.e. they have rigid or flexible behaviour, respectively. However, the terms “rigid” or “flexible” are a gross simplification which can lead to a misinterpretation by suggesting that the balance classification of the rotor is only dependent on its physical construction. Unbalance is an intrinsic property of the rotor, but the dynamics of the bearings and support structure and the rotational speed of the rotor can affect the rotor’s response to unbalance. The balance quality to which the rotor is expected to run and the magnitude and distribution of the initial unbalance along the rotor also influence the chosen balancing procedure to be used. As a result, a rotor that behaves as rigid under one set of conditions (service speed, initial unbalance, unbalance tolerances, etc.) can behave as flexible under another set of conditions.

Guidance on rigid and flexible rotor behaviours is given in [5.2](#) and [5.3](#).

There are special cases of rotors with unbalance indications that change with speed or time in a way that cannot be explained with a bending shaft. These are considered in [5.3.3](#) and [5.3.4](#).

5.2 Rotors with rigid behaviour

Rigid rotor behaviour is where the flexure of a rotor caused by its unbalance distribution can be neglected with respect to the agreed unbalance tolerance at any speed up to the maximum service speed. The majority of these rotors operate way below the rotor-support system resonance speed.

Rotors with rigid behaviour can be balanced in accordance with the requirements of ISO 21940-11. The aim of such balancing is to correct for the resultant unbalance, with at least a single-plane balance correction for static unbalance, or with at least a two-plane balance correction for the dynamic unbalance.