

ISO/TC 269/SC 2

Secretariat: AFNOR

Voting begins on:
2021-06-24

Voting terminates on:
2021-08-19

Railway applications — Suspension components —

Part 1: Characteristics and test methods for elastomer-mechanical parts

iTeh STANDARD PREVIEW
(standards.itih.ai)

Applications ferroviaires — Pièces de suspension à base d'élastomère —

Partie 1: Caractéristiques et méthodes d'essai pour les pièces en caoutchouc et les pièces en caoutchouc-métal

ISO/FDIS 22749-1

<https://standards.itih.ai/catalog/standards/sist/70777923-f73c-4d65-877f-f70ac5a9cd72/iso-fdis-22749-1>

RECIPIENTS OF THIS DRAFT ARE INVITED TO SUBMIT, WITH THEIR COMMENTS, NOTIFICATION OF ANY RELEVANT PATENT RIGHTS OF WHICH THEY ARE AWARE AND TO PROVIDE SUPPORTING DOCUMENTATION.

IN ADDITION TO THEIR EVALUATION AS BEING ACCEPTABLE FOR INDUSTRIAL, TECHNOLOGICAL, COMMERCIAL AND USER PURPOSES, DRAFT INTERNATIONAL STANDARDS MAY ON OCCASION HAVE TO BE CONSIDERED IN THE LIGHT OF THEIR POTENTIAL TO BECOME STANDARDS TO WHICH REFERENCE MAY BE MADE IN NATIONAL REGULATIONS.



Reference number
ISO/FDIS 22749-1:2021(E)

iTeh STANDARD PREVIEW
(standards.iteh.ai)

ISO/FDIS 22749-1
<https://standards.iteh.ai/catalog/standards/sist/70777923-f73c-4d65-877f-f70ac5a9cd72/iso-fdis-22749-1>



COPYRIGHT PROTECTED DOCUMENT

© ISO 2021

All rights reserved. Unless otherwise specified, or required in the context of its implementation, no part of this publication may be reproduced or utilized otherwise in any form or by any means, electronic or mechanical, including photocopying, or posting on the internet or an intranet, without prior written permission. Permission can be requested from either ISO at the address below or ISO's member body in the country of the requester.

ISO copyright office
CP 401 • Ch. de Blandonnet 8
CH-1214 Vernier, Geneva
Phone: +41 22 749 01 11
Email: copyright@iso.org
Website: www.iso.org

Published in Switzerland

Contents

	Page
Foreword.....	v
Introduction.....	vi
1 Scope.....	1
2 Normative references.....	1
3 Terms and definitions.....	2
4 Symbols and abbreviated terms.....	2
5 Three-dimensional definition of characteristics.....	5
6 Conditions of use.....	7
6.1 Environmental conditions.....	7
6.2 Operating temperatures.....	7
6.3 Operating loading conditions.....	7
6.4 Recycling.....	8
7 Definition of the product.....	8
7.1 General.....	8
7.1.1 Definition of characteristics.....	8
7.1.2 Mounting conditions.....	8
7.1.3 Ambient conditions.....	8
7.2 Resistance to environmental conditions.....	9
7.2.1 General.....	9
7.2.2 Low temperature.....	9
7.2.3 High temperature.....	10
7.2.4 Ozone.....	10
7.2.5 Oil and petroleum products.....	10
7.2.6 Chemical products.....	10
7.2.7 Abrasion.....	11
7.2.8 Fire behaviour.....	11
7.2.9 Corrosion.....	11
7.2.10 Other conditions.....	11
7.3 Resistance to operating conditions.....	11
7.3.1 Fatigue resistance.....	11
7.3.2 Static creep.....	12
7.3.3 Dynamic creep.....	12
7.3.4 Static relaxation.....	12
7.3.5 Dynamic relaxation.....	12
7.3.6 Electrical resistance.....	12
7.3.7 Other conditions.....	12
7.4 Physical characteristics.....	12
7.4.1 Materials.....	12
7.4.2 Mass.....	12
7.5 Geometrical and dimensional characteristics.....	13
7.5.1 Space envelope.....	13
7.5.2 Dimensions.....	13
7.6 Functional characteristics.....	13
7.6.1 Dimensions under load.....	13
7.6.2 Force under deformation.....	13
7.6.3 Characteristic "force as a function of displacement" at constant velocity.....	13
7.6.4 Stiffnesses under sinusoidal motion.....	16
7.6.5 Damping.....	18
7.6.6 Bonding test.....	19
8 Inspection and test methods.....	19
8.1 General.....	19

8.1.1	General test conditions.....	19
8.1.2	Instrumentation.....	20
8.1.3	Definition and preparation of test pieces.....	20
8.2	Resistance to environmental conditions.....	20
8.2.1	General.....	20
8.2.2	Low temperature.....	20
8.2.3	High temperature.....	20
8.2.4	Ozone.....	21
8.2.5	Oil and petroleum products.....	21
8.2.6	Chemical products.....	21
8.2.7	Abrasion.....	21
8.2.8	Fire behaviour.....	21
8.2.9	Corrosion.....	21
8.2.10	Other conditions.....	21
8.3	Resistance to operating conditions.....	21
8.3.1	Fatigue resistance.....	21
8.3.2	Static creep.....	22
8.3.3	Dynamic creep.....	24
8.3.4	Static relaxation.....	24
8.3.5	Dynamic relaxation.....	25
8.3.6	Electrical resistance.....	25
8.3.7	Other conditions.....	25
8.4	Physical characteristics.....	25
8.4.1	Materials.....	25
8.4.2	Mass.....	25
8.5	Geometrical and dimensional characteristics.....	25
8.5.1	Space envelope.....	25
8.5.2	Dimensions.....	25
8.6	Functional characteristics.....	25
8.6.1	Dimensions under load.....	25
8.6.2	Force under deformation.....	27
8.6.3	Characteristics "force as a function of displacement" at constant velocity.....	28
8.6.4	Stiffnesses under sinusoidal motion.....	30
8.6.5	Damping.....	32
8.6.6	Bonding test.....	33
9	Marking.....	33
Annex A (normative) Design of the test devices and analysis of the parasitic deformations during stiffness measurements.....		35
Annex B (informative) Two examples of fatigue test programmes.....		36
Annex C (informative) Recommended tolerances and acceptance criteria for characteristics of components.....		40
Annex D (informative) Recommended measurement velocities.....		42

Foreword

ISO (the International Organization for Standardization) is a worldwide federation of national standards bodies (ISO member bodies). The work of preparing International Standards is normally carried out through ISO technical committees. Each member body interested in a subject for which a technical committee has been established has the right to be represented on that committee. International organizations, governmental and non-governmental, in liaison with ISO, also take part in the work. ISO collaborates closely with the International Electrotechnical Commission (IEC) on all matters of electrotechnical standardization.

The procedures used to develop this document and those intended for its further maintenance are described in the ISO/IEC Directives, Part 1. In particular, the different approval criteria needed for the different types of ISO documents should be noted. This document was drafted in accordance with the editorial rules of the ISO/IEC Directives, Part 2 (see www.iso.org/directives).

Attention is drawn to the possibility that some of the elements of this document may be the subject of patent rights. ISO shall not be held responsible for identifying any or all such patent rights. Details of any patent rights identified during the development of the document will be in the Introduction and/or on the ISO list of patent declarations received (see www.iso.org/patents).

Any trade name used in this document is information given for the convenience of users and does not constitute an endorsement.

For an explanation of the voluntary nature of standards, the meaning of ISO specific terms and expressions related to conformity assessment, as well as information about ISO's adherence to the World Trade Organization (WTO) principles in the Technical Barriers to Trade (TBT), see www.iso.org/iso/foreword.html.

This document was prepared by Technical Committee ISO/TC 269, *Railway applications*, Subcommittee SC 2, *Rolling stock*.

A list of all parts in the ISO 22749 series can be found on the ISO website.

Any feedback or questions on this document should be directed to the user's national standards body. A complete listing of these bodies can be found at www.iso.org/members.html.

Introduction

This document is based on EN 13913.

Designing an elastomer- mechanical part requires knowledge of the mechanical system of which it forms part. Therefore, specific characteristics are needed for each case, which only the customer can specify.

This document is the result of the studies and research to improve the performances and quality of elastomer- mechanical parts in order to meet the requirements of railway rolling stock.

This document is designed for railway operators, manufacturers and equipment suppliers of the railway industry as well as for the suppliers of elastomer-mechanical parts.

iTeh STANDARD PREVIEW (standards.iteh.ai)

[ISO/FDIS 22749-1](https://standards.iteh.ai/catalog/standards/sist/70777923-f73c-4d65-877f-f70ac5a9cd72/iso-fdis-22749-1)

<https://standards.iteh.ai/catalog/standards/sist/70777923-f73c-4d65-877f-f70ac5a9cd72/iso-fdis-22749-1>

Railway applications — Suspension components —

Part 1:

Characteristics and test methods for elastomer-mechanical parts

1 Scope

This document applies to elastomer-mechanical parts designed to be fitted on railway vehicles and similar vehicles running on dedicated tracks with permanent guide systems, whatever the type of rail and the running surface.

Typical applications of the elastomer-mechanical parts include:

- vehicle suspension systems;
- equipment mounting systems;
- joints (e.g. end-mountings of dampers, rubber-based bearings, elastomer mechanical parts used on mechanical couplings);
- limit stops.

These parts can be:

- made entirely of elastomer, operating on their own or in combination with other elastic parts;
- made up of elastomer and other materials, adherent together or not.

This document specifies characteristics that rubber and rubber to metal parts are to achieve, together with applicable inspection and test methods to be carried out for verification.

This document does not apply to:

- rubber diaphragms for pneumatic suspension springs;
- elastic parts of buffing and drawgear springs;
- diaphragms, bellows and seals;
- hoses and tubings;
- transmission belts.

2 Normative references

The following documents are referred to in the text in such a way that some or all of their content constitutes requirements of this document. For dated references, only the edition cited applies. For undated references, the latest edition of the referenced document (including any amendments) applies.

ISO 188, *Rubber, vulcanized or thermoplastic — Accelerated ageing and heat resistance tests*

ISO 1431-1, *Rubber, vulcanized or thermoplastic — Resistance to ozone cracking — Part 1: Static and dynamic strain testing*

ISO 1817, *Rubber, vulcanized or thermoplastic — Determination of the effects of liquids*

ISO/FDIS 22749-1:2021(E)

ISO 2781, *Rubber, vulcanized or thermoplastic — Determination of density*

ISO 4649, *Rubber, vulcanized or thermoplastic — Determination of abrasion resistance using a rotating cylindrical drum device*

ISO 9227, *Corrosion tests in artificial atmospheres — Salt spray tests*

ISO 23529, *Rubber — General procedures for preparing and conditioning test pieces for physical test methods*

ISO 80000-3, *Quantities and units — Part 3: Space and time*

ISO 80000-4, *Quantities and units — Part 4: Mechanics*

3 Terms and definitions

For the purposes of this document, the following terms and definitions apply.

ISO and IEC maintain terminological databases for use in standardization at the following addresses:

- ISO Online browsing platform: available at <https://www.iso.org/obp>
- IEC Electropedia: available at <http://www.electropedia.org/>

3.1

component

elastomer-mechanical part

iTeh STANDARD PREVIEW
(standards.iteh.ai)

3.2

static creep

displacement increase of a *component* (3.1) subjected to a constant static force, occurring after a specified period of time

<https://standards.iteh.ai/catalog/standards/sist/70777923-f73c-4d65-877f-f70ac5a9cd72/iso-fdis-22749-1>

3.3

dynamic creep

displacement increase of a *component* (3.1) subjected to a dynamic force oscillating about a constant static force, occurring after a specified period of time

3.4

static relaxation

force decrease of a *component* (3.1) subjected to a constant displacement, occurring after a specified period of time

3.5

dynamic relaxation

force decrease of a *component* (3.1) submitted to a dynamic displacement oscillating about a constant static displacement, occurring after a specified period of time

3.6

phase angle

difference in phase between the transmitted excitation and the response at a specific sinusoidal amplitude and frequency

4 Symbols and abbreviated terms

The units presented in ISO 80000-3 and ISO 80000-4 shall be used for the symbols in [Table 1](#).

Decimal multiples and submultiples of units defined below can be used.

Table 1 — Symbols and abbreviations

Symbol	Unit	Explanation
a	m or rad	<p>amplitude of the movement; see Figure 1.</p>  <p>Key</p> <p>X time (t)</p> <p>Y displacement (linear, d, or angular, θ)</p> <p>1 d_{\max} (or θ_{\max})</p> <p>2 d_{\min} (or θ_{\min})</p> <p>3 d_p (or θ_p)</p> <p>Figure 1 — Amplitude of the movement</p>
C	N or Nm	<p>amplitude of the force (or the moment); see Figure 2.</p>  <p>Key</p> <p>X time (t)</p> <p>Y force (F) or moment (M)</p> <p>1 F_{\max} (or M_{\max})</p> <p>2 F_{\min} (or M_{\min})</p> <p>3 F_p (or M_p)</p> <p>Figure 2 — Amplitude of the force (or the moment)</p>
d	m	linear displacement
d_j	m	displacement (d_1 ; d_2 ; etc.) corresponding to a force F_j with $d_0 < d_j < d_M$
d_0	m	lower data limit for the definition of the stiffness characteristics
d_M	m	upper data limit for the definition of the stiffness characteristics
d_{\min}	m	minimum displacement on a sinusoidal motion (see Figure 1)
d_{\max}	m	maximum displacement on a sinusoidal motion (see Figure 1)
d_p	m	mean displacement (see Figure 1)
F	N	static force

Table 1 (continued)

Symbol	Unit	Explanation
F_j	N	force ($F_1; F_2$; etc.) corresponding to a displacement d_j with $F_0 < F_j < F_M$
F_0	N	lower data limit for the definition of the stiffness characteristics
F_M	N	upper data limit for the definition of the stiffness characteristics
F_{\min}	N	minimum force on a sinusoidal motion (see Figure 2)
F_{\max}	N	maximum force on a sinusoidal motion (see Figure 2)
F_p	N	mean force (see Figure 2)
F_C	N	reference force taken into account for the creep test (static and dynamic)
F_L	N	reference force taken into account for the definition of the dimensions of the component under load
f	Hz	frequency
k_{dyn}	N/m	stiffness under sinusoidal motion NOTE Characteristic of the component measured along an axis, under a sinusoidal motion.
k_s	N/m	characteristic "force as a function of linear displacement" at constant velocity NOTE Characteristic of the component measured along an axis, at constant velocity.
$k\theta_{\text{dyn}}$	Nm/rad	rotational stiffness under sinusoidal motion NOTE Characteristic of the component measured around an axis, under a sinusoidal motion.
$k\theta_s$	Nm/rad	characteristic "moment as a function of rotational displacement" at constant velocity NOTE Characteristic of the component measured around an axis, at constant velocity.
L	m	dimension of the component
L_j	m	dimension ($L_1; L_2$; etc.) under a static force F_j
L_0	m	dimension at F_0 (or M_0)
L_D	m	reference dimension taken into account for the definition of the force given by the component under deformation
L_M	m	dimension at F_M (or M_M)
L_R	m	reference dimension taken into account for the relaxation test (static and dynamic)
M	Nm	Moment applied around an axis of the component
M_j	Nm	moment ($M_1; M_2$; etc.) corresponding to an angle of displacement θ_j with $M_0 < M_j < M_M$
M_0	Nm	lower limit value for the definition of the stiffness characteristics
M_M	Nm	upper limit value for the definition of the stiffness characteristics
M_{\min}	Nm	minimum moment on a sinusoidal motion (see Figure 2)
M_{\max}	Nm	maximum moment on a sinusoidal motion (see Figure 2)
M_p	Nm	mean moment (see Figure 2)
R_C	m/decade	creep rate NOTE It is permissible to use % / decade instead of m/decade.
T_e	°C	ambient temperature (temperature of the air surrounding the component) in extreme and exceptional situations
$T_{e,\min}$	°C	ambient temperature (temperature of the air surrounding the component) in extreme and exceptional situations: lower temperature
$T_{e,\max}$	°C	ambient temperature (temperature of the air surrounding the component) in extreme and exceptional situations: higher temperature
θ	rad	angle of displacement in a plane around an axis of the component

Table 1 (continued)

Symbol	Unit	Explanation
θ_j	rad	angle of displacement (θ_1 ; θ_2 ; etc.) corresponding to a moment M_j with $\theta_0 < \theta_j < \theta_M$
θ_0	rad	lower limit value for the definition of the stiffness characteristics
θ_M	rad	upper limit value for the definition of the stiffness characteristics
θ_{\min}	rad	minimum angle of displacement on a sinusoidal motion (see Figure 1)
θ_{\max}	rad	maximum angle of displacement on a sinusoidal motion (see Figure 1)
θ_p	rad	mean angular displacement (see Figure 1)
		NOTE It is permissible to use angular units of degrees instead of radians.
δ	rad	phase angle

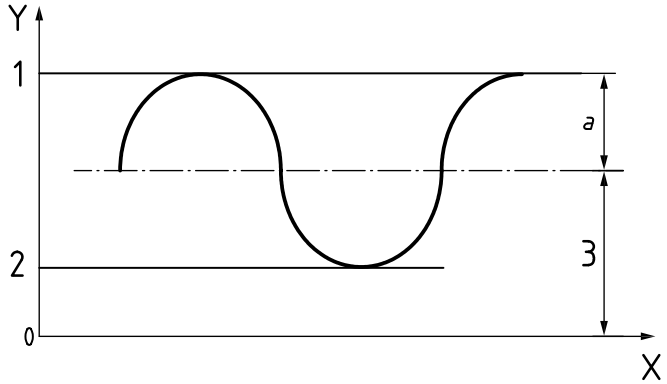
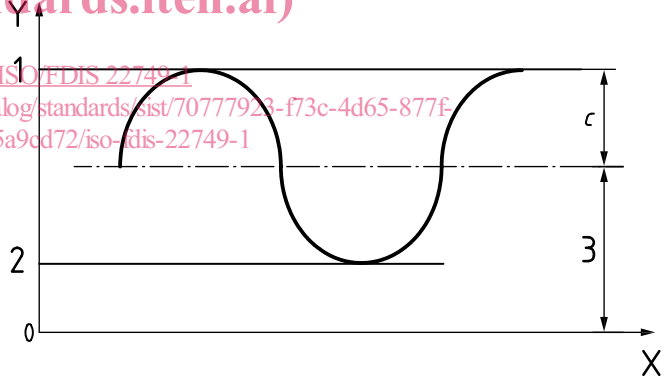
5 Three-dimensional definition of characteristics

In the absence of any reference system and specific co-ordinates in the definition documents, the following arrangements shall be made.

Using the X-Y-Z axes to orientate the vehicle in space, a Cartesian reference point, O_{xyz} , related to the vehicle and with a supposedly fixed point within the mechanical system to which the component belongs as origin, is established as follows:

- axis O_x parallel to the longitudinal axis of vehicle X;
- axis O_y parallel to the transverse axis of vehicle Y;
- axis O_z parallel to the vertical axis of vehicle (or normal axis) Z.

The displacements corresponding to the degrees of freedom are:

- displacement parallel to axis O_x : d_x
- displacement parallel to axis O_y : d_y
- displacement parallel to axis O_z : d_z
- rotation around axis O_x : θ_x
- rotation around axis O_y : θ_y
- rotation around axis O_z : θ_z

The positive direction of rotation is clockwise looking from the origin.

The mechanical characteristics associated with the displacements are:

- for d_x : stiffnesses k_{sx} and k_{dynx} ; force F_x
- for d_y : stiffnesses k_{sy} and k_{dyny} ; force F_y
- for d_z : stiffnesses k_{sz} and k_{dynz} ; force F_z
- for θ_x : stiffnesses $k\theta_{sx}$ and $k\theta_{dynx}$; moment M_x
- for θ_y : stiffnesses $k\theta_{sy}$ and $k\theta_{dyny}$; moment M_y
- for θ_z : stiffnesses $k\theta_{sz}$ and $k\theta_{dynz}$; moment M_z

These provisions are illustrated by Figure 3. Figures 4 and 5 illustrate the main directions defining the characteristics of a joint and spring, respectively.

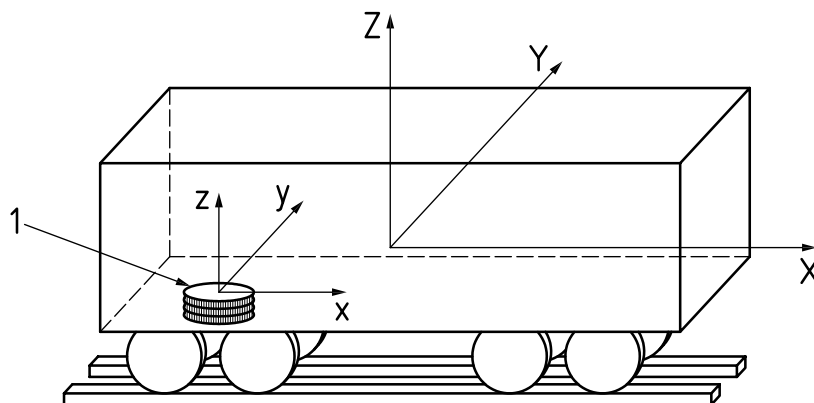

Key
1 component

Figure 3 — Three-dimensional definition of characteristics

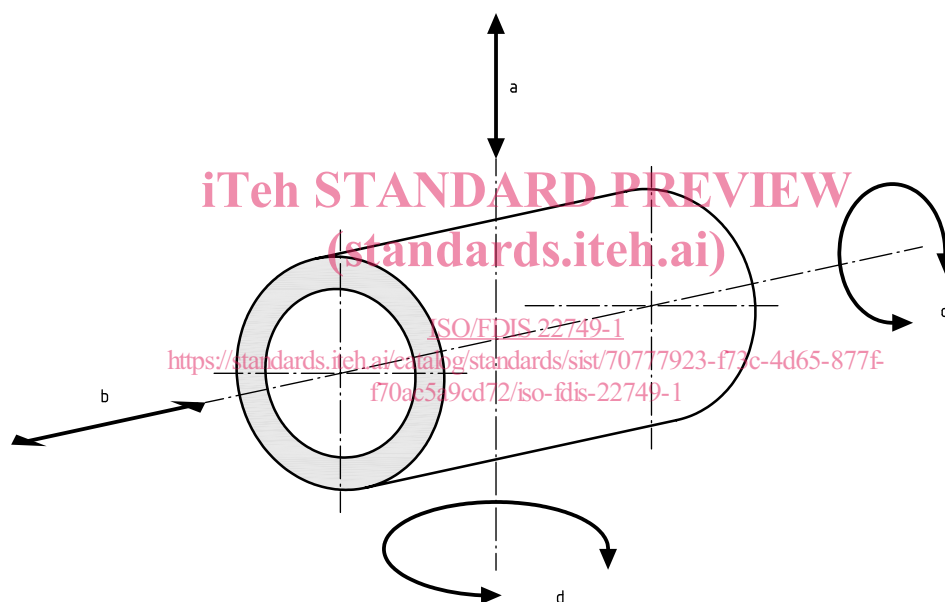

Key
a Radial.
b Axial.
c Torsional.
d Conical.

Figure 4 — Main directions defining the characteristics of a joint (example: elastic bush)

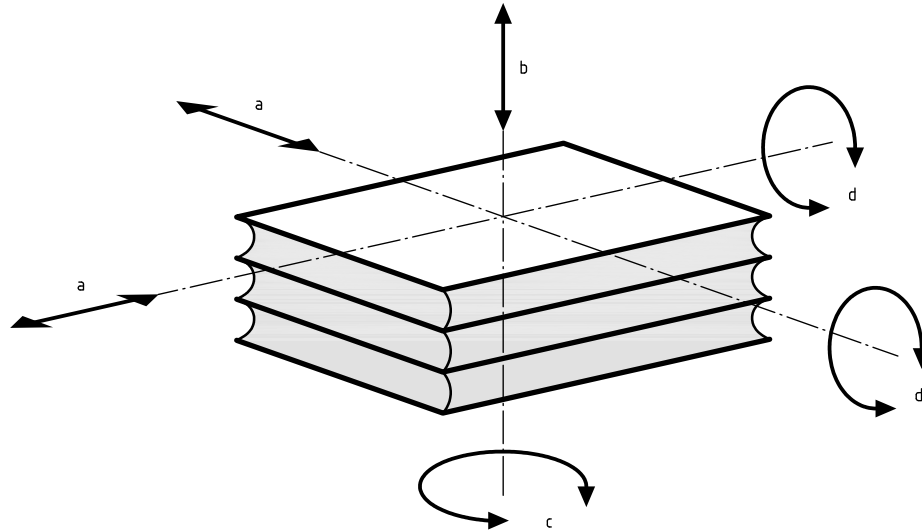
**Key**

- a Radial.
- b Axial.
- c Torsional.
- d Conical.

Figure 5 — Main directions defining the characteristics of a spring (example: layer spring)
 (standards.iteh.ai)

6 Conditions of use

[ISO/FDIS 22749-1](https://standards.iteh.ai/catalog/standards/sist/70777923-f73c-4d65-877f-70ac5a9cd72/iso-fdis-22749-1)

[https://standards.iteh.ai/catalog/standards/sist/70777923-f73c-4d65-877f-](https://standards.iteh.ai/catalog/standards/sist/70777923-f73c-4d65-877f-70ac5a9cd72/iso-fdis-22749-1)

6.1 Environmental conditions

According to its position on the vehicle and its service conditions (including storage, depot and qualification test of the vehicle), the component can be subject to attack from sources such as:

- chemical products (cleaning products for example);
- organic waste;
- oil sprays;
- environmental conditions.

These conditions shall be defined in the technical specification.

6.2 Operating temperatures

The operating temperatures range shall be defined in the technical specification.

6.3 Operating loading conditions

During its service life, the component is subjected to loading conditions such as vibration, forces and displacements (linear and angular), due to the function of the mechanical system to which it is fitted.

These loading conditions shall be taken into consideration for the definition of the component. Therefore, they shall be defined in the technical specification.

6.4 Recycling

The technical specification may specify requirements relating to the final disposal of the component.

The supplier of the component shall inform the customer of the recyclability of the materials used.

7 Definition of the product

7.1 General

7.1.1 Definition of characteristics

The necessary characteristics for the definition of the component according to its usage and operating conditions shall be indicated in the technical specification.

These characteristics shall be selected from those specified in [Tables 2](#) and [3](#).

The selected characteristics shall be defined according to the instructions of this document.

The component shall comply with the selected criteria defined in the technical specification.

Recommended tolerances are given in [Annex C](#).

7.1.2 Mounting conditions

Any mounting conditions which can have an influence on the characteristics (e.g. component prestressed when installed) shall be defined in the technical specification.

7.1.3 Ambient conditions

Unless otherwise specified, the characteristics of the component are defined with an ambient temperature of $(23 \pm 2) ^\circ\text{C}$.

Specific characteristics may be defined for different conditions. In this case, the technical specification shall specify:

- the characteristics concerned;
- the temperature;
- the criteria.

Table 2 — Component characteristics

Characteristic	Characteristic definition	Inspection and test method
Resistance to environmental conditions		
Low temperature	7.2.2	8.2.2
High temperature	7.2.3	8.2.3
Ozone	7.2.4	8.2.4
Oil and petroleum products	7.2.5	8.2.5
Chemical products	7.2.6	8.2.6
Abrasion	7.2.7	8.2.7
Fire behaviour	7.2.8	8.2.8
Corrosion	7.2.9	8.2.9
Other conditions	7.2.10	8.2.10

Table 2 (continued)

Characteristic	Characteristic definition	Inspection and test method
Resistance to operating conditions		
Fatigue resistance	7.3.1	8.3.1
Static creep	7.3.2	8.3.2
Dynamic creep	7.3.3	8.3.3
Static relaxation	7.3.4	8.3.4
Dynamic relaxation	7.3.5	8.3.5
Electrical resistance	7.3.6	8.3.6
Other conditions	7.3.7	8.3.7
Physical characteristics		
Materials	7.4.1	8.4.1
Mass	7.4.2	8.4.2
Geometrical and dimensional characteristics		
Space envelope	7.5.1	8.5.1
Dimensions	7.5.2	8.5.2

Table 3 — Component characteristics

Functional characteristic	Characteristic definition	Inspection and test method
Characteristics "force as a function of displacement" at constant velocity		
In a new condition	7.6.3.2	8.6.3.2
After test	7.6.3.3	8.6.3.3
Stiffnesses under sinusoidal motion		
In new condition	7.6.4.2	8.6.4.2
After test	7.6.4.3	8.6.4.3
Damping		
In new condition	7.6.5.2	8.6.5.2
After test	7.6.5.3	8.6.5.3
Other characteristics		
Dimensions under load	7.6.1	8.6.1
Force under deformation	7.6.2	8.6.2
Bonding test	7.6.6	8.6.6

7.2 Resistance to environmental conditions

7.2.1 General

Some characteristics are defined on test pieces (see [8.2.1](#)). Results obtained on test pieces can differ from the actual performances of the component. This shall be taken into account when defining these characteristics.

7.2.2 Low temperature

Where the characteristic is selected, the component shall be able to withstand low temperature.