



Designation: E 570 – 97

Standard Practice for Flux Leakage Examination of Ferromagnetic Steel Tubular Products¹

This standard is issued under the fixed designation E 570; the number immediately following the designation indicates the year of original adoption or, in the case of revision, the year of last revision. A number in parentheses indicates the year of last reapproval. A superscript epsilon (ϵ) indicates an editorial change since the last revision or reapproval.

This standard has been approved for use by agencies of the Department of Defense.

1. Scope

1.1 This practice covers the application and calibration of equipment using the flux leakage test method for detection of outer surface, inner surface, and subsurface discontinuities in ferromagnetic steel tubular products (Note 1) of uniform cross section such as seamless and welded tubing.

NOTE 1—The term “tube” or “tubular product” will be used to refer to both pipe and tubing.

1.2 This practice is intended for use on tubular products having outside diameters from approximately $\frac{1}{2}$ to 24 in. (12.7 to 610 mm) with wall thicknesses to $\frac{1}{2}$ in (12.7 mm). These techniques have been used for other sizes, however, and may be so specified upon contractual agreement between the purchaser and the supplier.

1.3 This practice does not establish acceptance criteria; they must be specified by the using parties.

1.4 *This standard does not purport to address the safety concerns, if any, associated with its use. It is the responsibility of the user of this standard to establish appropriate safety and health practices and determine the applicability of regulatory limitations prior to use.*

2. Referenced Documents

2.1 ASTM Standards:

E 543 Practice for Evaluating Agencies that Perform Non-destructive Testing²

E 1316 Terminology for Nondestructive Examinations²

2.2 Other Documents:

SNT-TC-1A Recommended for Personnel Qualification and Certification of Nondestructive Testing Personnel³

ANSI/ASNT CP-189 ASNT Standard for Qualification and Certification of Nondestructive Testing Personnel³

¹ This practice is under the jurisdiction of ASTM Committee E-7 on Nondestructive Testing and is the direct responsibility of Subcommittee E07.07 on Electromagnetic Method.

Current edition approved May 10, 1997. Published February 1998. Originally published as E 570-76. Last previous edition E 570-91.

² Annual Book of ASTM Standards, Vol 03.03.

³ Available from American Society for Nondestructive Testing, 1711 Arlington Plaza, PO Box 28518, Columbus, Ohio 43228-0518.

MIL-STD-410 Nondestructive Testing Personnel Qualification⁴

3. Terminology

3.1 Definitions of terms relating to flux leakage examination are provided in Terminology E 1316.

4. Summary of Practice

4.1 This method consists of the following steps:

4.1.1 The tube wall is magnetized at the area under test to a proper level approaching magnetic saturation.

NOTE 2—Tubes subjected to magnetic inspections can retain various strengths and configuration of residual magnetic fields depending upon the magnetization technique. If the residual field resulting from a given technique can interfere with subsequent applications of the tube, then a supplemental demagnetization process may be required.

4.1.2 A flux sensor containing magnetic transducers is placed on or above the outside surface of the tube in the magnetized area.

4.1.3 Either the tube or the flux sensor is moved at a constant speed in the direction of the magnetic field so that the sensor scans the entire surface of the tube.

4.1.4 Each magnetic transducer in the flux sensor is connected to an electronic console which amplifies, filters, and electronically processes the signals such that significant discontinuities are indicated (visually, audibly), and marked with paint, or automatically removed from the production line, or both.

4.1.5 A suitable means for assuring near magnetic saturation of the product (subject to periodic check or calibration) must be provided as part of the test to verify the capability of detection of outside diameter and inside diameter discontinuities.

5. Significance and Use

5.1 This practice outlines a procedure for examining ferromagnetic tubular products using the flux leakage method. If properly applied, this method is capable of detecting the

⁴ Available from Standardization Documents Order Desk, Building 4 Section D, 700 Robbins Avenue, Philadelphia, PA 19111-5904, Attn: NPODS.

presence and location of significant longitudinally or transversely oriented discontinuities such as pits, scabs, slivers, gouges, roll-ins, laps, seams, cracks, holes, and improper welds in ferromagnetic tubes under inspection. In addition, the severity of a discontinuity may be estimated and a rejection level set with respect to the magnitude of the electromagnetic indication produced by the discontinuity.

5.2 The response from natural discontinuities can be significantly different from the response for artificial discontinuities such as drilled holes or notches of equivalent depth. For this reason, sufficient work should be done to determine the conditions necessary to detect and mark *natural* discontinuities whose characteristics will adversely affect the serviceability of the tube, in order to establish acceptance criteria between the supplier and purchaser.

6. Basis of Application

6.1 The following criteria may be specified in the purchase specification, contractual agreement, or elsewhere, and may require agreement between the purchaser and supplier:

- 6.1.1 Acceptance criteria.
- 6.1.2 Type, dimensions, location, and number of artificial discontinuities to be placed on the reference standard.
- 6.1.3 Size and type of tubing to be examined.
- 6.1.4 Extent of examination (that is, full length, weld zone only if welded, etc.).
- 6.1.5 Disposition of material with discontinuity indications.
- 6.1.6 Methods of verifying dimensions of artificial discontinuities and allowable tolerances.
- 6.1.7 Time of inspection, that is, the point(s) in the manufacturing process at which the material will be inspected.
- 6.1.8 Nondestructive testing (NDT) personnel shall be qualified in accordance with a nationally recognized NDT personnel qualification practice or standard such as ANSI/ASNT CP-189, SNT-TC-1A, MIL-STD-410 or a similar document. The practice or standard used and its applicable revision shall be specified in the purchase specification or contractual agreement between the using parties.
- 6.1.9 If specified in the purchase specification or contractual agreement, NDT agencies shall be evaluated and qualified as described in Practice E 543. The applicable edition of Practice E 543 shall be identified in the purchase specification or contractual agreement between the using parties.

7. Interferences

7.1 There are some manufacturing processes that produce tubing with surface conditions that could interfere with or obscure signals related to inner surface discontinuities. In the examination of heavy-walled tubing having these conditions, the ability to test reliably for inner surface discontinuities may be affected.

7.2 When examining tubes with large rapid surface variations, false signals may be caused by the sensors bouncing along the surface of the tubes.

7.3 For active pole magnetizing systems, a small air gap between the magnetizing system and material under test could cause a heavy accumulation of scale buildup on the pole pieces.

DETECTION OF LONGITUDINAL DISCONTINUITIES

8. Apparatus

8.1 *Rotary Mechanism*—The rotary mechanism shall be capable of rotating a magnetizing system or flux leakage sensors, or both, in unison around tubing that is being translated axially through the mechanism, thereby producing a helical scan over the surface. Good examination practices require that the pole pieces of the magnetizing system rotate uniformly about the tube and that the flux sensor ride on the tube or be spaced uniformly above the surface of the tube during rotation.

8.2 *Spin Feed Mechanism*—The spin feed mechanism shall be capable of positioning a magnetizing system or flux leakage sensors, or both, on or near the surface of a translating rotating tube such that there is a uniform spacing between the pole pieces of the magnetizing system and the tube. The flux leakage sensors shall ride on the surface of the tube or be held uniformly from the surface of the tube during test.

8.3 *Magnetizing System:*

8.3.1 An active field magnetizing system consists of a suitable means of applying a strong adjustable transverse magnetic field to the region of the tube under the flux sensors and shall be capable of bringing that region of the tube to near saturation. Typical systems employ either permanent magnets or controllable electromagnets. If permanent magnets are used, a means shall be provided to adjust the spacing of the pole pieces in order to reach the proper magnetization level. Refer to Section 13 for application of longitudinal magnetic fields.

8.3.2 A residual field magnetizing system consists of a means of applying a circular residual magnetic field to an entire tube before the tube is inspected. Typical systems employ a centrally positioned conducting rod through which a high direct current is passed; alternatively, the current may be conducted through the tube itself. The current produces a circular active magnetic field which is concentric with the current distribution. When the current ceases, there remains a residual magnetic field which is circular, concentric with the tube, and wholly contained within the tube wall.

8.4 *Flux Leakage Sensors:*

8.4.1 The flux sensor shall consist of magnetic field transducers that respond to variations in magnetic flux density. These sensors generally consist of one of the following types: electromagnetic coils, Hall probes, magneto diodes, magnitors, or magnetoresistors. These sensors are normally used to detect the flux leakage directly from the discontinuity in the tube; however, they may also be used to detect flux leakage patterns that have been transferred from the tube to a strip of magnetic tape. The flux sensors should be of sufficient number and length so as to provide 100 % coverage while scanning the tube surface to be tested at the desired examination speed. Their location (with respect to the magnetic pole pieces and the tubular product) should result in maximum response to the leakage field caused by a discontinuity in the tubular product.

8.4.2 The depth and orientation of a discontinuity below the outside surface will affect the magnitude of the signal received from it. Sensitivity decreases significantly as the distance between the flux leakage sensor and the tube under test is

increased. Therefore, the sensors should remain clean and have uniform contact with the tube surface, or if air riding the sensors should be held at a uniform distance above the surface of the tube.

8.5 *Electronic Instrumentation*—The electronic apparatus shall be capable of amplifying signals from the flux sensors and processing them for the operation of alarms. Multiple probes may be used to increase the speed of test. The signals may be processed in two separate channels to result in a differentiation between inner and outer surface discontinuities. Each of the two sets of electronic channels should contain its own sensitivity and threshold triggering controls for independent setting of percentage of wall rejection levels.

8.6 *Driving Mechanism*—A mechanical drive mechanism shall be used which is capable of rigidly holding and passing

the tube through the inspection apparatus at constant speed and concentric with the inspection apparatus. As required, the driving mechanism shall be capable of rotating and advancing, or just advancing the tube with a constant speed.

9. Principles of Examination

9.1 Conduct the examination of tubular products for longitudinal discontinuities employing a transverse magnetic field and flux leakage detectors using one or more of the following techniques:

9.1.1 Obtain a transverse magnetic field by either (1) positioning north and south poles of a magnet on opposite sides of a tube on a diameter or chord as shown in Fig. 1(a) and 1(b); or (2) passing a high direct current through a conducting rod centrally positioned in the tube under test.

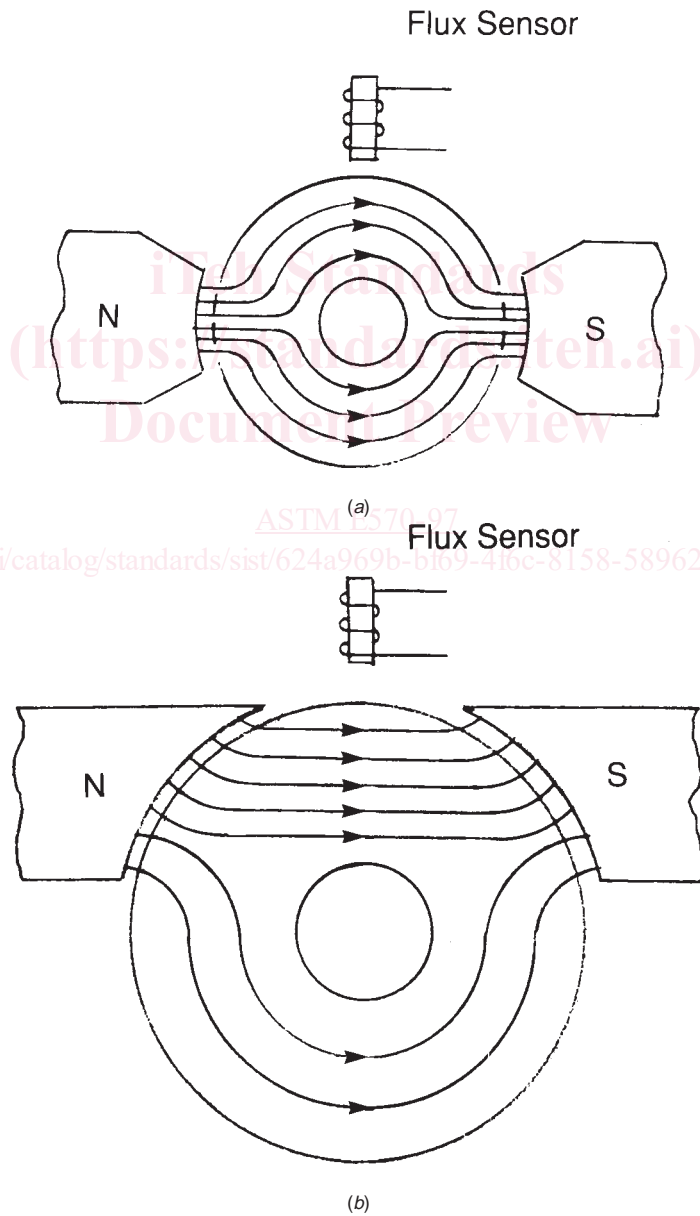

FIG. 1 Transverse Magnetization