**Machine tools — Test conditions
for external cylindrical centreless
grinding machines — Testing of the
accuracy**

*Machines-outils — Conditions d'essai des machines à rectifier les
surfaces extérieures sans centre — Contrôle de l'exactitude*

iTeh Standards
(<https://standards.itih.ai>)
Document Preview

[ISO 3875:2020](https://standards.itih.ai/catalog/standards/iso/c3354ae4-552e-4fb1-ac6b-d7cf1e3fc25d/iso-3875-2020)

<https://standards.itih.ai/catalog/standards/iso/c3354ae4-552e-4fb1-ac6b-d7cf1e3fc25d/iso-3875-2020>



iTeh Standards
(<https://standards.iteh.ai>)
Document Preview

[ISO 3875:2020](https://standards.iteh.ai/catalog/standards/iso/c3354ae4-552e-4fb1-ac6b-d7cf1e3fc25d/iso-3875-2020)

<https://standards.iteh.ai/catalog/standards/iso/c3354ae4-552e-4fb1-ac6b-d7cf1e3fc25d/iso-3875-2020>



COPYRIGHT PROTECTED DOCUMENT

© ISO 2020

All rights reserved. Unless otherwise specified, or required in the context of its implementation, no part of this publication may be reproduced or utilized otherwise in any form or by any means, electronic or mechanical, including photocopying, or posting on the internet or an intranet, without prior written permission. Permission can be requested from either ISO at the address below or ISO's member body in the country of the requester.

ISO copyright office
CP 401 • Ch. de Blandonnet 8
CH-1214 Vernier, Geneva
Phone: +41 22 749 01 11
Fax: +41 22 749 09 47
Email: copyright@iso.org
Website: www.iso.org

Published in Switzerland

Contents

Page

Foreword	iv
Introduction	v
1 Scope	1
2 Normative references	1
3 Terms and definitions	1
4 Terminology, designation of axes and machine configurations	2
5 Preliminary remarks	3
5.1 Measuring units.....	3
5.2 Reference to ISO 230-1 and ISO 230-2.....	4
5.3 Machine levelling.....	4
5.4 Testing sequence.....	4
5.5 Tests to be performed.....	4
5.6 Measuring instruments.....	4
5.7 Machining tests.....	4
5.8 Software compensation.....	5
5.9 Axis not under test.....	5
5.10 Minimum tolerance.....	5
6 Geometric tests	6
7 Accuracy and repeatability of positioning	12
7.1 Positioning of manual or automatic (but not numerically controlled) linear axes.....	12
7.2 Positioning of numerically controlled linear axes.....	13
8 Machining tests	17
8.1 In-feed grinding.....	17
8.2 Through-feed grinding.....	18
Annex A (informative) Terms in other languages	19
Bibliography	20

Foreword

ISO (the International Organization for Standardization) is a worldwide federation of national standards bodies (ISO member bodies). The work of preparing International Standards is normally carried out through ISO technical committees. Each member body interested in a subject for which a technical committee has been established has the right to be represented on that committee. International organizations, governmental and non-governmental, in liaison with ISO, also take part in the work. ISO collaborates closely with the International Electrotechnical Commission (IEC) on all matters of electrotechnical standardization.

The procedures used to develop this document and those intended for its further maintenance are described in the ISO/IEC Directives, Part 1. In particular, the different approval criteria needed for the different types of ISO documents should be noted. This document was drafted in accordance with the editorial rules of the ISO/IEC Directives, Part 2 (see www.iso.org/directives).

Attention is drawn to the possibility that some of the elements of this document may be the subject of patent rights. ISO shall not be held responsible for identifying any or all such patent rights. Details of any patent rights identified during the development of the document will be in the Introduction and/or on the ISO list of patent declarations received (see www.iso.org/patents).

Any trade name used in this document is information given for the convenience of users and does not constitute an endorsement.

For an explanation of the voluntary nature of standards, the meaning of ISO specific terms and expressions related to conformity assessment, as well as information about ISO's adherence to the World Trade Organization (WTO) principles in the Technical Barriers to Trade (TBT) see www.iso.org/iso/foreword.html.

This document was prepared by Technical Committee ISO/TC 39, *Machine tools*, Subcommittee SC 2, *Test conditions for metal cutting machine tools*.

Any feedback or questions on this document should be directed to the user's national standards body. A complete listing of these bodies can be found at www.iso.org/members.html.

This fourth edition cancels and replaces the third edition (ISO 3875:2004), which has been technically revised. The main changes compared to the previous edition are as follows:

- the machine sizes (thickness of grinding wheel) covered have been extended more than 300 mm from ISO 3875:2004 for test M1 since machine size in the industry increased;
- machine configurations have been classified into three types to cover major configurations in the markets;
- references to ISO 230-1 and ISO 230-2 have been revised;
- a new machine test for Z-directional grinding wheel slide (straightness and positioning) has been introduced.

Introduction

The purpose of this document is to standardize methods of testing the accuracy of general purpose and normal accuracy external cylindrical centreless grinding machines. The primary function of such machines is to provide cylindrical workpieces. This document specifies the tests to verify the geometric accuracy of the machine to achieve this primary function.

iTeh Standards
(<https://standards.itih.ai>)
Document Preview

[ISO 3875:2020](https://standards.itih.ai/catalog/standards/iso/c3354ae4-552e-4fb1-ac6b-d7cf1e3fc25d/iso-3875-2020)

<https://standards.itih.ai/catalog/standards/iso/c3354ae4-552e-4fb1-ac6b-d7cf1e3fc25d/iso-3875-2020>

Machine tools — Test conditions for external cylindrical centreless grinding machines — Testing of the accuracy

1 Scope

The document specifies, with reference to ISO 230-1 and ISO 230-2, geometric tests, machining tests and tests for accuracy and repeatability of positioning axes on general purpose and normal accuracy manually and numerically controlled (NC) external cylindrical centreless grinding machines. It also specifies the applicable tolerances corresponding to the above-mentioned tests.

This document deals only with the verification of accuracy of the machine. It does not apply to the testing of the machine operation (vibrations, abnormal noise, stick-slip motion of components, etc.) nor to machine characteristics (such as speeds, feeds, etc.), which are generally checked before testing of machine accuracy.

This document provides the terminology used for the principal components of the machine and the designation of the axes with reference to ISO 841.

NOTE In addition to the terms used in the official ISO languages (English and French), this document gives the equivalent terms in the German, Italian, Japanese, and Persian languages. These are published under the responsibility of the national member bodies for Germany (DIN), Italy (UNI), Japan (JIS), and Iran (ISIRI). However, only the terms given in the official languages can be considered as ISO terms.

2 Normative references

The following documents are referred to in the text in such a way that some or all of their content constitutes requirements of this document. For dated references, only the edition cited applies. For undated references, the latest edition of the referenced document (including any amendments) applies.

ISO 230-1:2012, *Test code for machine tools — Part 1: Geometric accuracy of machines operating under no-load or quasi-static conditions*

ISO 230-2:2014, *Test code for machine tools — Part 2: Determination of accuracy and repeatability of positioning of numerically controlled axes*

3 Terms and definitions

For the purposes of this document, the following terms and definitions apply.

ISO and IEC maintain terminological databases for use in standardization at the following addresses:

- ISO Online browsing platform: available at <https://www.iso.org/obp>
- IEC Electropedia: available at <http://www.electropedia.org/>

3.1

centreless grinding

grinding for the generation of external faces of a rotating workpiece, position of which is mechanically guided against the grinding wheel by a regulating wheel and a work support located between the regulating and grinding wheels

3.2

centreless grinding machine

machine tool intended to machine workpieces by means of two rotating grinding wheels and work support

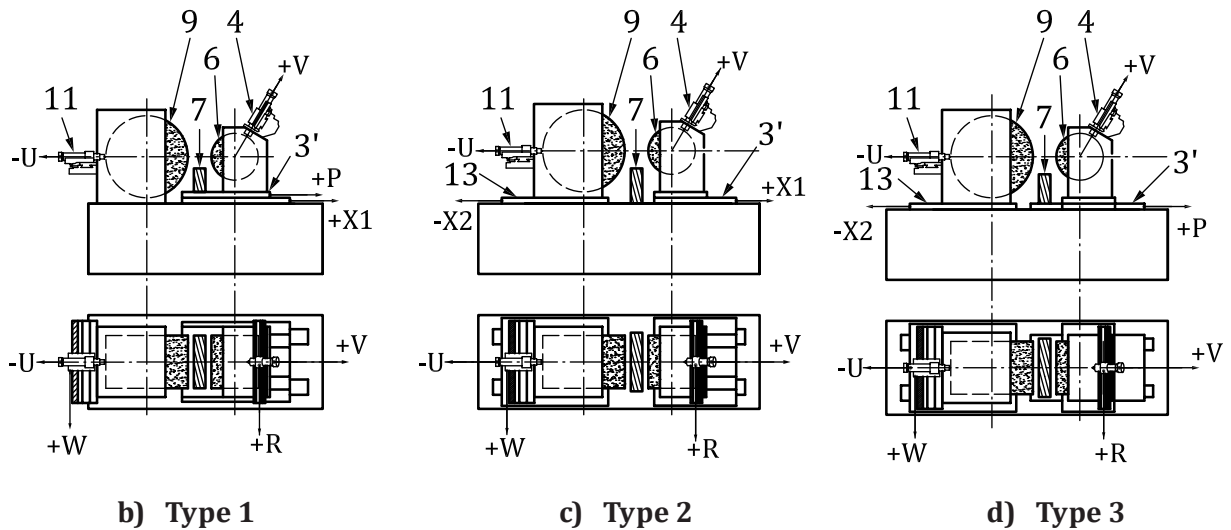

Key

English	French
1 bed	banc
2 regulating wheel guideway	guidage de la meule d'entraînement
3 regulating wheel slide (X1-axis)	chariot porte-meule d'entraînement (axe X1)
3' regulating wheel auxiliary slide (P-axis)	chariot auxiliaire de la meule d'entraînement (axe P)
4 regulating wheel dresser (R- and V-axis)	dispositif de dressage pour meule d'entraînement (axe R et V)
5 regulating wheel head	poupée porte-meule d'entraînement
6 regulating wheel (C2-axis)	meule d'entraînement (axe C2)
7 work support blade	lame support de pièce
8 work support	appui de la lame
9 grinding wheel (C1-axis)	meule (axe C1)
10 grinding wheel head	poupée porte-meule
11 grinding wheel dresser (U- and W-axis)	dispositif de dressage pour meule (axe U et W)
12 workpiece	pièce
13 grinding wheel slide (X2-axis)	chariot de la meule (axe X2)
14 grinding wheel axial slide (Z1-axis)	chariot axial de la meule (axe Z1)
15 reference surface S (vertical direction)	surface de référence S (direction verticale)
16 reference surface S' (horizontal direction)	surface de référence S' (direction horizontale)

Figure 1 — Examples of a centreless grinding machine including all configurations

5 Preliminary remarks

5.1 Measuring units

In this document, all linear dimensions, errors and corresponding tolerances are expressed in millimetres (mm); angular dimensions are expressed in degrees (°), and angular errors and the corresponding tolerances are expressed in ratios, but in some cases microradians (µrad) or arcsec (") may be used for clarification purposes. [Formula \(1\)](#) should be used for conversion of the units of angular errors or tolerances:

$$0,010/1\ 000 = 10\ \mu\text{rad} \cong 2\ \text{arcsec} \quad (1)$$

5.2 Reference to ISO 230-1 and ISO 230-2

To apply this document, reference shall be made to ISO 230-1 and ISO 230-2, especially for the installation of the machine before testing, the warming up of spindles and other moving components, description of measuring methods and recommended measurement uncertainty of testing equipment.

Where the test concerned is in compliance with the specifications of ISO 230-1 and ISO 230-2, a reference to the corresponding subclause in ISO 230-1 and ISO 230-2 is shown before the instructions in the "Observations" block of the tests described in [Clauses 6 to 8](#).

5.3 Machine levelling

Before conducting tests on a machine, the machine should be levelled according to the recommendations of the supplier/manufacturer (see ISO 230-1:2012, 6.1.1).

5.4 Testing sequence

The sequence in which the tests are presented in this document does not define the practical order of testing. In order to make the mounting of instruments or gauging easier, tests may be performed in any order.

5.5 Tests to be performed

When testing a machine, it is not always necessary or possible to carry out all the tests described in this document. When the tests are required for acceptance purposes, it is up to the user to choose, in agreement with the supplier/manufacturer, those tests relating to the components and/or the properties of the machine which are of interest. These tests are to be clearly stated when ordering a machine. A simple reference to this document for the acceptance tests, without specifying the tests to be carried out, and without agreement on the relevant expenses, cannot be considered as binding for any contracting party.

5.6 Measuring instruments

Measuring instruments indicated in the tests described in [Clauses 6 to 8](#) are examples only. Other instruments capable of measuring the same quantities and having the same, or a smaller, measurement uncertainty may be used. Reference shall be made to ISO 230-1:2012, Clause 5, which indicates the relationship between measurement uncertainties and the tolerances.

When a dial gauge is referred to, it can mean not only dial test indicators (DTI) but any type of linear displacement sensor such as analogue or digital dial gauges, linear variable differential transformer (LVDTs), linear scale displacement gauges, or non-contact sensors, when applicable to the test concerned (see ISO 230-1:2012, Clause 4).

Similarly, when a straightedge is referred to, it can mean any type of straightness reference artefact, such as a granite or ceramic or steel or cast iron straightedge, one arm of a square, one generating line on a cylindrical square, any straight path on a reference cube, or a special, dedicated artefact manufactured to fit in the T-slots or other references.

Valuable information for measuring instruments are available in ISO/TR 230-11.

5.7 Machining tests

Machining tests shall be made with finishing cuts only. Roughing cuts shall be avoided since they are liable to generate appreciable cutting forces.