**Geotechnical investigation and
testing — Geotechnical monitoring by
field instrumentation —**

Part 4:
**Measurement of pore water pressure:
Piezometers**

iTeh STANDARD PREVIEW
(standards.iteh.ai)

*Reconnaissance et essais géotechniques — Surveillance géotechnique
par instrumentation in situ —*

Partie 4: Mesure de la pression interstitielle: Piézomètres

<https://standards.iteh.ai/catalog/standards/sist/a5643d99-e402-438a-9be8-ef89d0385057/iso-18674-4-2020>



iTeh STANDARD PREVIEW (standards.iteh.ai)

ISO 18674-4:2020

<https://standards.iteh.ai/catalog/standards/sist/a5643d99-e402-438a-9be8-ef89d0385057/iso-18674-4-2020>



COPYRIGHT PROTECTED DOCUMENT

© ISO 2020

All rights reserved. Unless otherwise specified, or required in the context of its implementation, no part of this publication may be reproduced or utilized otherwise in any form or by any means, electronic or mechanical, including photocopying, or posting on the internet or an intranet, without prior written permission. Permission can be requested from either ISO at the address below or ISO's member body in the country of the requester.

ISO copyright office
CP 401 • Ch. de Blandonnet 8
CH-1214 Vernier, Geneva
Phone: +41 22 749 01 11
Email: copyright@iso.org
Website: www.iso.org

Published in Switzerland

Contents

	Page
Foreword	iv
1 Scope	1
2 Normative references	1
3 Terms and definitions	1
4 Symbols and abbreviated terms	7
5 Instruments	7
5.1 General	7
5.2 Open piezometer systems	9
5.2.1 General	9
5.2.2 Types of open piezometer systems	10
5.3 Closed piezometer systems	13
5.3.1 General	13
5.3.2 Types of closed piezometer systems	16
5.4 Absolute versus relative measurements and atmospheric compensation	17
5.5 Requirements for filters	19
5.5.1 Filters in open piezometer systems	19
5.5.2 Filters in closed piezometer systems	19
5.6 Measuring range and accuracy	20
6 Installation and measuring procedure	20
6.1 Installation	20
6.1.1 General	20
6.1.2 Installation of open piezometer systems	21
6.1.3 Installation of closed piezometer systems	23
6.1.4 Checks before, during and after installation	24
6.1.5 Maintenance	25
6.2 Carrying out the measurement	25
6.2.1 Instrumentation check and calibration	25
6.2.2 Measurement	26
7 Data processing and evaluation	26
8 Reporting	26
8.1 Installation report	26
8.2 Monitoring report	26
Annex A (normative) Measuring and evaluation procedure	27
Annex B (informative) Geo-engineering applications	34
Annex C (informative) Protection of piezometers at the ground level	36
Annex D (informative) Response time for pore water pressure measurements	39
Annex E (normative) Fully grouted piezometer installation	42
Annex F (normative) Measuring negative pore water pressure (soil suction)	44
Annex G (informative) Measuring examples	45
Bibliography	57

Foreword

ISO (the International Organization for Standardization) is a worldwide federation of national standards bodies (ISO member bodies). The work of preparing International Standards is normally carried out through ISO technical committees. Each member body interested in a subject for which a technical committee has been established has the right to be represented on that committee. International organizations, governmental and non-governmental, in liaison with ISO, also take part in the work. ISO collaborates closely with the International Electrotechnical Commission (IEC) on all matters of electrotechnical standardization.

The procedures used to develop this document and those intended for its further maintenance are described in the ISO/IEC Directives, Part 1. In particular, the different approval criteria needed for the different types of ISO documents should be noted. This document was drafted in accordance with the editorial rules of the ISO/IEC Directives, Part 2 (see www.iso.org/directives).

Attention is drawn to the possibility that some of the elements of this document may be the subject of patent rights. ISO shall not be held responsible for identifying any or all such patent rights. Details of any patent rights identified during the development of the document will be in the Introduction and/or on the ISO list of patent declarations received (see www.iso.org/patents).

Any trade name used in this document is information given for the convenience of users and does not constitute an endorsement.

For an explanation of the voluntary nature of standards, the meaning of ISO specific terms and expressions related to conformity assessment, as well as information about ISO's adherence to the World Trade Organization (WTO) principles in the Technical Barriers to Trade (TBT) see www.iso.org/iso/foreword.html.

This document was prepared by Technical Committee ISO/TC 182, *Geotechnics*, in collaboration with the European Committee for Standardization (CEN) Technical Committee CEN/TC 341, *Geotechnical Investigation and Testing*, in accordance with the Agreement on technical cooperation between ISO and CEN (Vienna Agreement).

A list of all parts in the ISO 18674 series can be found on the ISO website.

Any feedback or questions on this document should be directed to the user's national standards body. A complete listing of these bodies can be found at www.iso.org/members.html.

Geotechnical investigation and testing — Geotechnical monitoring by field instrumentation —

Part 4:

Measurement of pore water pressure: Piezometers

IMPORTANT — The electronic file of this document contains colours which are considered to be useful for the correct understanding of the document. Users should therefore consider printing this document using a colour printer.

1 Scope

This document specifies the measurement of pore water pressures and piezometric levels in saturated ground by means of piezometers installed for geotechnical monitoring. General rules of performance monitoring of the ground, of structures interacting with the ground, of geotechnical fills and of geotechnical works are presented in ISO 18674-1.

If applied in conjunction with ISO 18674-5, the procedures described in this document allow the determination of effective stresses acting in the ground.

This document is applicable to:

- monitoring of water pressures acting on and in geotechnical structures (e.g. quay walls, dikes, excavation walls, foundations, dams, tunnels, slopes, embankments, etc.);
- monitoring of consolidation processes of soil and fill (e.g. beneath foundations and in embankments);
- evaluating stability and serviceability of geotechnical structures;
- checking geotechnical designs in connection with the Observational Design procedure.

NOTE This document fulfils the requirements for the performance monitoring of the ground, of structures interacting with the ground and of geotechnical works by the means of piezometers, installed as part of the geotechnical investigation and testing in accordance with References [4] and [5]. This document relates to measuring devices, which are installed in the ground. For pore water pressure measurements carried out in connection with cone penetration tests, see ISO 22476-1.

2 Normative references

The following documents are referred to in the text in such a way that some or all of their content constitutes requirements of this document. For dated references, only the edition cited applies. For undated references, the latest edition of the referenced document (including any amendments) applies.

ISO 18674-1:2015, *Geotechnical investigation and testing — Geotechnical monitoring by field instrumentation — Part 1: General rules*

ISO 22475-1, *Geotechnical investigation and testing — Sampling by drilling and excavation methods and groundwater measurements — Part 1: Technical principles for execution*

3 Terms and definitions

For the purposes of this document, the terms and definitions given in ISO 18674-1 and the following apply.

ISO and IEC maintain terminological databases for use in standardization at the following addresses:

- ISO Online browsing platform: available at <https://www.iso.org/obp>
- IEC Electropedia: available at <http://www.electropedia.org/>

3.1
piezometer
field instrument system for measuring *pore water pressure* (3.2) or *piezometric level* (3.4) where the *measuring point* (3.15) is confined within the ground or geotechnical fill so that the measurement responds to the fluid pressure around the measuring zone/point and not to fluid pressures at other elevations

Note 1 to entry: The system consists of a sealed *reservoir* (3.1.2) filled with fluid, a *filter* (3.1.3) and a *measuring device* (3.1.7).

Note 2 to entry: The system is either an *open piezometer system* (3.6) or a *closed piezometer system* (3.7).

3.1.1
intake zone
zone confined by *seals* (3.1.6), between which water in the ground can flow to the measuring device, thus defining the *measuring point* (3.15)

Note 1 to entry: See [Figure 1](#).

Note 2 to entry: It is assumed that a hydrostatic *pore water pressure* (3.2) distribution is established along the intake zone.

Note 3 to entry: The constant of proportionality between flow into or out of a *piezometer* (3.1) and the change of pore water pressure is called the intake factor *F*.

3.1.2
reservoir
space between the ground and the *measuring device* (3.1.7), occupied by a fluid, which allows the *pore water pressure* (3.2) to act on the sensing element of the measuring device

Note 1 to entry: The pores within the *filter* (3.1.3) are an integral part of the reservoir.

Note 2 to entry: In *open piezometer systems* (3.6), the water-filled part of the standpipe is part of the reservoir.

3.1.3
filter
permeable section of a *piezometer* (3.1) defining the *intake zone* (3.1.1), which allows water to enter and at the same time restricts soil particles entering the standpipe or *measuring device* (3.1.7)

Note 1 to entry: The filter can be a combination of elements, such as a sand pocket, a perforated pipe, a geotextile sleeve, a filter tip (3.1.4) and grout backfill in specific cases.

3.1.4
filter tip
filter (3.1.3) element which is a common part of a *closed piezometer system* (3.7)

Note 1 to entry: Filter tips are formed of a material with purpose-designed pore diameters, i.e. *HAE filter* (3.1.4.1) or *LAE filter* (3.1.4.2).

3.1.4.1
high air entry filter
HAE filter
filter tip (3.1.4) with comparatively small pores giving a higher resistance to the passage of air than to the passage of water

Note 1 to entry: Commonly, high air entry filter tips have pore diameters of between 1 µm and 3 µm.

Note 2 to entry: HAE filter tips are used when it is intended to keep gas out of the *measuring device* (3.1.7).

Note 3 to entry: In unsaturated soil or when negative *pore water pressures* (3.2) are to be measured (i.e. suction; see Annex F), the pressure of the gaseous phase is always higher than that of the pore water. The required pore diameter of the HAE filter tip depends on the difference between the pore air pressure and the pore water pressure.

3.1.4.2 low air entry filter LAE filter

filter tip (3.1.4) with comparatively large pores giving a lower resistance to the passage of air readily allowing the passage of both air and water

Note 1 to entry: Commonly, low air entry filter tips have pore diameters of between 20 µm and 50 µm.

3.1.5 filter pack

permeable material, placed around a slotted section of an open *piezometer* (3.1) or around the *filter tip* (3.1.4), allowing water to reach the *measuring device* (3.1.7)

3.1.6 seal

layer in a borehole, made with a material that has a permeability suitable for hydraulic separation of two *aquifers* (3.10)

Note 1 to entry: Seals are generally used to confine an *intake zone* (3.1.1).

3.1.7 measuring device

part of the *piezometer* (3.1) system used to measure the *piezometric level* (3.4) in an *open system* (3.6) or the *pore water pressure* (3.2) in a *closed system* (3.7)

Note 1 to entry: For an *open piezometer system* (3.6), the measuring device is commonly a *water level meter* (3.1.7.1) for manual measurements or a pressure transducer for automatic measurements.

Note 2 to entry: For a *closed piezometer system* (3.7), the measuring device is typically a diaphragm pressure transducer (see 7b in Figure 1 b)). The diaphragm separates a *reservoir* (3.1.2) and an inner chamber in the transducer. The deflection of the diaphragm is a function of the *pore water pressure* (3.2) (see Figure 3).

Note 3 to entry: For closed piezometer systems, the measuring device is often synonymously termed a piezometer in a narrow sense.

3.1.7.1 water level meter

measuring device with a marked length measuring tape and a tip that activates a signal (light, sound) when it comes into contact with water

Note 1 to entry: A water level meter is commonly used for manual measurements in *open systems* (3.6) or during the installation procedure of *piezometers* (3.1).

3.1.7.2 electric piezometer

piezometer (3.1) where the *measuring device* (3.1.7) has a diaphragm and the deflection of the diaphragm due to *pore water pressure* (3.2) is measured by an electric sensor

Note 1 to entry: Electric piezometers are commonly based on strain gauge, piezo-electric, vibrating wire or capacitive sensors. Data acquisition devices exist which accommodate all types of electric piezometers.

Note 2 to entry: See Figure 3.

3.1.7.3

fibre optic piezometer

piezometer (3.1) where the pressure *measuring device* (3.1.7) has a diaphragm and the deflection of the diaphragm is measured by an optical sensor

Note 1 to entry: Fibre optic piezometers do not require electrical connection between read-out unit and sensor.

Note 2 to entry: Fibre optic piezometers require a dedicated read-out unit.

3.1.7.4

pneumatic piezometer

piezometer (3.1) where the pressure *measuring device* (3.1.7) has a valve which is opened pneumatically by a gas pressure, which is applied from the outside via gas-filled tubes and closed by the *pore water pressure* (3.2)

Note 1 to entry: See [Figure 4](#).

3.2

pore water pressure

u

pressure of the water in the voids of the ground or a fill, relative to the atmospheric pressure

Note 1 to entry: The pore water pressure is the difference between the total stress and the effective stress in saturated ground (see References [6] and [7]).

Note 2 to entry: For rocks, the associated term is joint water pressure.

Note 3 to entry: The state of soil or fill where the pores are completely filled with water is referred to as “saturated”.

Note 4 to entry: Pore water pressure measurements can yield positive or negative values (see Reference [8] and [Annex F](#)). Instruments that directly measure negative pore pressures are sometimes termed ‘tensiometers’, but are not within the scope of this document (see [ISO 11276](#)).

Note 5 to entry: Measurements of the pore water pressure can be affected by changes of the atmospheric pressure (see [5.4.1](#) and [Annex A](#)).

3.3

pressure head

ψ

ratio u/γ_w of the *pore water pressure* *u* (3.2) and the specific weight of water γ_w above a point

Note 1 to entry: For an *open piezometer system* (3.6), it is proportional to the elevation difference between the *piezometric level* (3.4) and the level of the *measuring point* (3.15) (see [Figure 1](#)).

3.4

piezometric level

z_w

elevation to which water will rise in an *open standpipe piezometer* (3.6.1) and at which the pressure of the water in the ground is equal to that of the ambient atmosphere

Note 1 to entry: The piezometric level z_w is the sum of the geometric elevation z and the *pressure head* ψ (3.3):
 $z_w = z + u/\gamma_w$

Note 2 to entry: See [Figure 1](#).

3.5

groundwater table water table

elevation at which *pore water pressure* *u* (3.2) is zero

Note 1 to entry: See [Figure 1](#).

Note 2 to entry: An equivalent term is phreatic surface.

Note 3 to entry: The groundwater level is the level of the groundwater table at a geographical coordinate.

3.6

open system

open piezometer system

field instrument system in which the fluid is in direct contact with the atmosphere and the *piezometric level* (3.4) at the *measuring point* (3.15) is measured

3.6.1

open standpipe piezometer

open piezometer system (3.6), consisting of a pipe (installed in the ground) which, at its upper end, is open to the atmosphere and with a perforated section, located in the *intake zone* (3.1.1)

Note 1 to entry: See [Figure 1 a](#)).

Note 2 to entry: Typical inner diameters of the pipe are from 19 mm to 60 mm.

3.6.2

Casagrande piezometer

open standpipe piezometer (3.6.1) with one or two comparatively small inner diameter pipes and a porous *filter tip* (3.1.4) at the *measuring point* (3.15)

Note 1 to entry: See [5.2.2.4](#), [Figure 2](#) and Reference [9].

3.6.3

monitoring well

open standpipe piezometer (3.6.1) with a large inner diameter of the pipe (typically ≥ 100 mm)

Note 1 to entry: A monitoring well can be used as *standpipe piezometer* (3.1), if the *response time* (3.9) is satisfactory (see [Annex D](#)).

Note 2 to entry: A monitoring well is often used for taking samples of the groundwater or for performing pumping tests.

3.6.4

observation well

open pipe within a borehole, where the *intake zone* (3.1.1) is unconfined

Note 1 to entry: Observation wells are often incorrectly termed *open standpipe piezometers* (3.6.1). Observation wells do not classify as *piezometers* (3.1) as they do not have *seals* (3.1.6).

Note 2 to entry: See [5.2.2.3.2](#).

3.7

closed system

closed piezometer system

measuring system in which the *reservoir* (3.1.2) is not in direct contact with the atmosphere and in which the pressure in the fluid is measured by a pressure *measuring device* (3.1.7)

Note 1 to entry: See [Figure 1 b](#)).

Note 2 to entry: Examples for pressure measuring devices, used in closed systems, are electric transducers, fibre optic transducers and pressure valves.

3.7.1

diaphragm piezometer

closed system (3.7) with a *filter tip* (3.1.4), a small *reservoir* (3.1.2) and diaphragm which separates the pore water from the measuring system

Note 1 to entry: The deflection of the diaphragm is measured and the signal is transported through a cable to an accessible location.

Note 2 to entry: Possible diaphragm piezometers are *electric piezometers* (3.1.7.2) or *fibre optic piezometers* (3.1.7.3).

Note 3 to entry: The pressure is measured adjacent to the filter tip.

3.7.2
closed hydraulic twin-tube piezometer

closed system (3.7) with a porous ceramic *filter tip* (3.1.4) located within an *intake zone* (3.1.1) and connected to a remote location via twin fluid filled tubes

Note 1 to entry: The pressure measurement takes place at the remote location and not at the filter tip. The measurements need to be adjusted for elevation differences between the filter tip and the remote location.

3.7.3
probe piezometer

closed system (3.7) where a moveable *measuring device* (3.1.7) is inserted into a pipe which is equipped with one or more measuring ports, each located at an *intake zone* (3.1.1)

3.8
multi-level piezometer

system with several *measuring points* (3.15) permanently installed at different elevations in the ground, where each measuring point has its own *intake zone* (3.1.1)

3.9
hydrodynamic time lag response time

time span between a change of the *pore water pressure* (3.2) in the ground and the associated change in the measurement

Note 1 to entry: The time lag depends primarily on the type and dimensions of the *piezometer* (3.1) (essentially the size of the *reservoir* (3.1.2)), the permeability of the ground and the installation procedure (see Annex D).

Note 2 to entry: The term "slow response time" of the piezometer is synonymous with a long hydrodynamic time lag.

3.10
aquifer

body of permeable rock or soil mass suitable for containing and transmitting groundwater

3.11
unconfined aquifer

aquifer (3.10) in which the groundwater surface forms the upper boundary

3.12
confined aquifer

aquifer (3.10) which is bounded above and below by *aquicludes* (3.14)

3.13
confining layer
aquitard

a low permeability layer of rock or soil that restricts groundwater flow and separates *aquifers* (3.10)

3.14
aquiclude

body of soil or rock with extremely low transmissivity, which effectively prevents the flow of water through the ground

3.15
measuring point

point in the ground where the *pore water pressure* (3.2) is referenced to

4 Symbols and abbreviated terms

Symbol	Name	Unit
A	cross-sectional area of the standpipe	m ²
d	borehole diameter / diameter of intake zone	m
D	diameter of a standpipe	m
F	intake factor	—
FS	full scale	—
GWT	groundwater table	—
HAE	high air entry	—
k_s	hydraulic conductivity of soil	m/s
k_g	hydraulic conductivity of grout	m/s
L	length of intake zone	m
LAE	low air entry	—
p	pressure	kPa
q_u	unconfined compressive strength	Pa
RL	reference level	—
t	time	s
u	pore water pressure	kPa
z	geometric height	m
z_{mp}	geometric height of the measuring point	m
z_w	piezometric level	m
γ_w	unit weight of water	kN/m ³
ψ	pressure head	m

5 Instruments

5.1 General

5.1.1 Open piezometer systems and closed piezometer systems should be distinguished from each other (see [Table 1](#) and [Figure 1](#)).

Table 1 — Piezometer types

No.	Type	Sub-type	Feature
1	Open piezometer system (see 5.2)	<ul style="list-style-type: none"> — open standpipe piezometer — monitoring well — Casagrande piezometer 	<p>A filter and reservoir, installed in the ground and open to the atmosphere.</p> <p>The measuring device is retrievable. Readings can be manual or automatic.</p> <p>An advantage of open systems is the possibility that automatic measurements can be checked against manual measurements.</p> <p>Open piezometers may not have a suitable response time in low permeability soils.</p>

Table 1 (continued)

No.	Type	Sub-type	Feature
2	Closed piezometer system (see 5.3)	<ul style="list-style-type: none"> — electric, fibre optic or probe piezometer — pneumatic piezometer — twin-tube piezometer 	<p>A filter, a reservoir and a pressure transducer are installed in the ground and are closed from the atmosphere.</p> <p>Retrievable pressure transducers are possible using special systems.</p> <p>Closed systems commonly have a shorter time lag than open systems.</p>

5.1.2 The choice between open or closed systems should be made according to the monitoring plan (see ISO 18674-1:2015, 4.3) and in consideration of the loading conditions and the hydrodynamic time lag of the system.

NOTE 1 The choice between open or closed system is crucial and can be a decisive factor on success or failure of the measurement. For example, in undrained conditions, an open system will not correctly follow the true changes of pore water pressure (see Annex D).

NOTE 2 Climatic conditions play also an important role when choosing between an open and a closed system. For example, when there is a risk of freezing conditions, a closed system is preferred.

5.1.3 The intake zone of the filter should be limited to an adequately short vertical section of the aquifer.

NOTE Pore water pressures can vary with depth or in stratified aquifers or when vertical groundwater flow is present.

iTech STANDARD PREVIEW
(standards.iteh.ai)

5.1.4 All components and equipment intended for installation in the ground shall be sufficiently resistant to mechanical loading and chemical attack by constituents in the groundwater. Any reactions between the materials used and the ground, in particular consequences of diverse electrochemical potential e.g. galvanic effects, shall be prevented.

NOTE Differences in electrochemical potential can cause modified pore water pressures. This effect emanates from gases generated by electric currents created by using different metals or alloys in the piezometer tip and/or filter material.

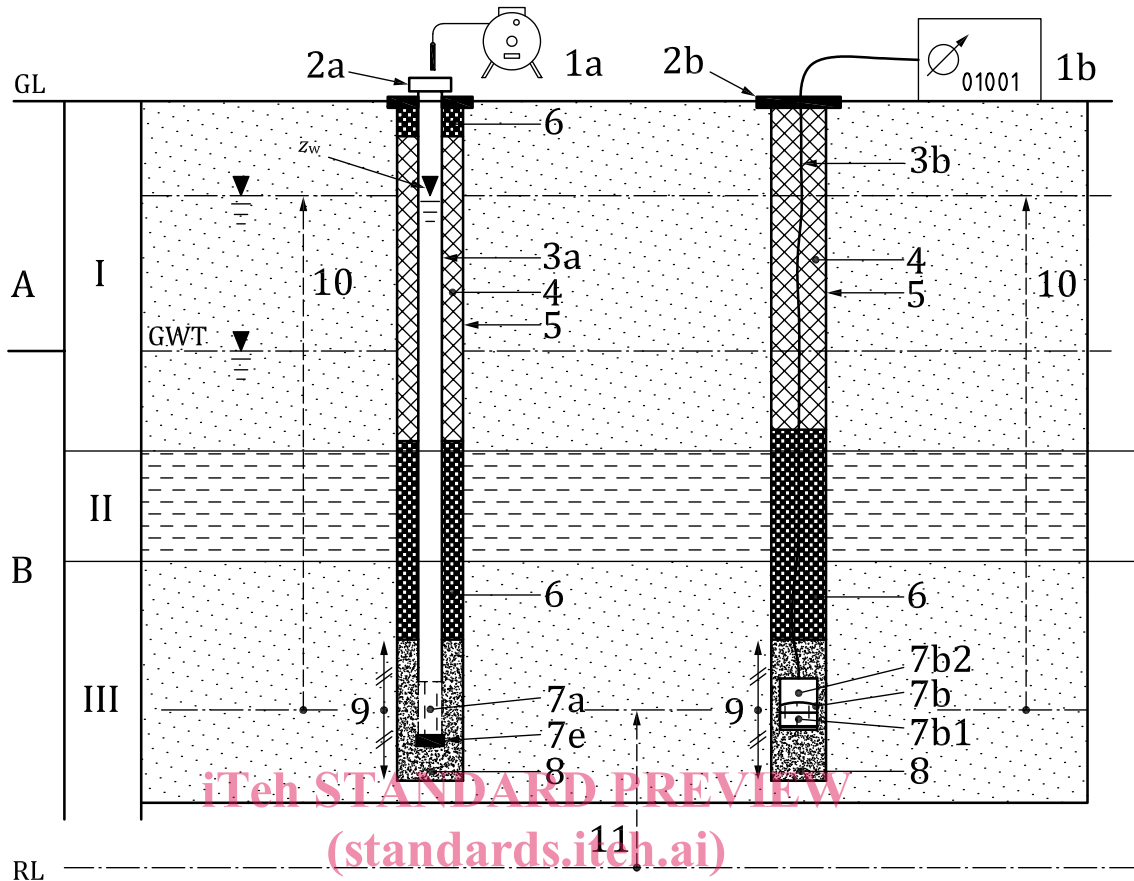

a) Open system

ISO 18674-4:2020

b) Closed system

<https://standards.iteh.ai/catalog/standards/sist/a5643d99-e402-438a-9be8-ef89d0385057/iso-18674-4-2020>

Key

GL	Ground Level	A	zone above GWT	B	zone below GWT
I	unconfined aquifer	II	aquiclude or aquitard	III	confined aquifer
z_w	piezometric level in III	GWT	groundwater table in I	RL	reference level (e. g. sea level)
1a	water level meter	1b	readout unit with barometer	2a	vented top cap with base plate
2b	base plate	3a	standpipe	3b	signal cable
4	backfill	5	borehole wall	6	seal
7a	perforated or slotted section	7b	pressure measuring device	7b1	reservoir with filter tip
7b2	inner chamber of transducer	7e	end cap	8	filter pack
9	intake zone	10	pressure head	11	elevation of measuring point relative to RL

Figure 1 — Types of piezometer systems

5.2 Open piezometer systems

5.2.1 General

5.2.1.1 An open piezometer system shall include the following components: a filter around the measuring point, a seal above the filter and an open pipe which extends from the filter through the seal up to the ground surface.

EXAMPLE See [Figure 1 a\)](#).

NOTE 1 The water pressure at the piezometric level is in equilibrium with the atmospheric pressure.

NOTE 2 If the borehole extends deeper than the intake zone, a seal is placed below the filter. It is also good practice to include a seal below the filter if horizontal flow is required (e.g. for performing rising or falling head tests).

5.2.1.2 The measuring point of an open piezometer is defined as the midpoint of the intake zone.

NOTE 1 The piezometric level, measured at the measuring point of an open piezometer is influenced by the intake zone. A hydrostatic pressure distribution is assumed over the height of the intake zone.

NOTE 2 For an open piezometer, the measuring point is not related to the position of the measuring device. For example, when using a pressure transducer in an open piezometer, the measuring point remains the centre of the intake zone, which is usually not the position of the pressure transducer.

5.2.1.3 The top cap of the standpipe shall be equipped with a vent to permit unrestricted variations of the water level inside the pipe.

5.2.1.4 Measurements can be conducted either by determining the piezometric level (e.g. by a water level meter) or by measuring the water pressure in the standpipe at a specified depth below the piezometric level (e.g. by using a pressure transducer). When a pressure transducer is used to determine the piezometric level, compensation for atmospheric variations should be considered (see 5.4).

5.2.1.5 In case of artesian conditions and an overflow of the standpipe, the standpipe can be extended to a level above the highest piezometric level or the open system can be converted to a closed system (see 5.3), e.g. by sealing a pressure gauge onto the top end of the standpipe.

ITEH STANDARDS PREVIEW
(standards.iteh.ai)

5.2.2 Types of open piezometer systems

ISO 18674-4:2020

5.2.2.1 General

<https://standards.iteh.ai/catalog/standards/sist/a5643d99-e402-438a-9be8-ef89d0385057/iso-18674-4-2020>

Open piezometer systems can be of the following types:

- Open standpipe piezometer
- Monitoring well
- Casagrande piezometer

5.2.2.2 Open standpipe piezometer

An open standpipe piezometer shall include the following components:

- a straight pipe with a minimum inner diameter of 12 mm;

NOTE 1 The minimum inner diameter is related to self-de-airing of open standpipe systems.

NOTE 2 Main considerations in the selection of the inner diameter are the ground conditions and the hydrodynamic time lag. Larger diameter pipes have longer hydrodynamic time lags.

- a slotted or perforated section of the lower part of the standpipe;

NOTE 3 When used in highly permeable ground with large and rapid water variations, the openings in the perforated or slotted pipe need to be sufficiently large to minimise flow resistance.

- a filter pack around the slotted or perforated section of the standpipe according to 5.5.1.1 and 5.5.1.2;
- a sealing plug of at least 1 m above the filter pack to confine the intake zone and to avoid rain water directly entering the piezometer system;

NOTE 4 When using clay pellets to form a seal, it is good practice to have at least 1 m of the seal below the groundwater level in order to allow the pellets to swell. When this is not possible, it is good practice to use a grout mixture as the seal.

- a sealing plug of at least one meter length in each confining layer. The location and length of the plug should be adjusted to the local ground conditions.

5.2.2.3 Monitoring well

5.2.2.3.1 A monitoring well (see [3.6.3](#)) with appropriate seals may be used as an open standpipe piezometer (see [5.2.2.2](#)) as long as the response time is acceptable for purpose.

5.2.2.3.2 Monitoring wells should be clearly distinguished from observation wells. As the groundwater regime cannot be known a priori, the use of observation wells is strongly discouraged.

NOTE Observation wells (see [3.6.4](#)) do not classify as piezometers as they do not have seals and thus can create connections between different aquifers and disturb the groundwater regime. The use of observation wells is limited to the measurement of the groundwater level in the uppermost layer of the ground in which, from the groundwater table, the water pressure increases uniformly with depth.

5.2.2.4 Casagrande piezometer

5.2.2.4.1 A Casagrande piezometer shall include the following components:

- a low air entry filter made from appropriate material such as quartz sand, ceramic material, sintered metal or porous plastic, placed in a borehole;
- one or two standpipes of a comparatively small inner diameter attached to the filter coming up to the surface.

[ISO 18674-4:2020](#)

NOTE 1 See [Figure 2](#). <https://standards.iteh.ai/catalog/standards/sist/a5643d99-e402-438a-9be8-ef89d0385057/iso-18674-4-2020>

NOTE 2 A typical inner diameter of the standpipes is 12 mm. Smaller inner diameters can be used, but it is possible that they are not self-de-airing.

5.2.2.4.2 With dual pipes the piezometer can be flushed to remove air and/or soil particles out of the system.

NOTE 1 With dual pipes (see [Figure 2 b](#)), the diameter of the pipes can be smaller than 12 mm.

NOTE 2 The use of a larger diameter pipe (see [Figure 2 c](#)) allows the installation of a pressure measuring device within the standpipe. The device can be retrieved and replaced.

NOTE 3 Using a special tip connection (see 9 in [Figure 2 c](#)), a Casagrande piezometer can be converted to a closed piezometer system. The pipe(s) can be closed by a device which includes a pressure transducer and a suitable solution to seal the casing(s).