



Designation: E 571 – 98

Standard Practice for Electromagnetic (Eddy-Current) Examination of Nickel and Nickel Alloy Tubular Products¹

This standard is issued under the fixed designation E 571; the number immediately following the designation indicates the year of original adoption or, in the case of revision, the year of last revision. A number in parentheses indicates the year of last reapproval. A superscript epsilon (ϵ) indicates an editorial change since the last revision or reapproval.

1. Scope

1.1 This practice² covers the procedures for eddy-current testing of nickel and nickel alloy tubes. These procedures are applicable for tubes with outside diameters up to 2 in. (50.8 mm), incl, and wall thicknesses from 0.035 to 0.120 in. (0.889 to 3.04 mm), incl. These procedures may be used for tubes beyond the size range recommended, by contractual agreement between the purchaser and the producer.

1.2 The procedures described in this practice make use of fixed encircling test coils or probe systems.

1.3 The values stated in inch-pound units are to be regarded as the standard.

NOTE 1—For convenience, the term “tube” or “tubular product” will hereinafter be used to refer to both pipe and tubing.

1.4 *This standard does not purport to address all of the safety concerns, if any, associated with its use. It is the responsibility of the user of this standard to establish appropriate safety and health practices and determine the applicability of regulatory limitations prior to use.*

2. Referenced Documents

2.1 *ASTM Standards:*

E 309 Practice for Eddy-Current Examination of Steel Tubular Products Using Magnetic Saturation³

E 543 Practice for Agencies Performing Nondestructive Testing³

E 1316 Terminology for Nondestructive Examinations³

2.2 *Other Documents:*

SNT-TC-1A Recommended Practice for Personnel Qualification and Certification in Nondestructive Testing⁴

ANSI/ASNT-CP-189 ASNT Standard for Qualification and Certification of Nondestructive Testing Personnel⁴

MIL-STD-410E Nondestructive Testing Personnel Qualifi-

cation and Certification⁵

NAS-410 Certification and Qualification of Nondestructive Personnel (Quality Assurance Committee)⁶

3. Terminology

3.1 Standard terminology relating to electromagnetic examination may be found in Terminology E 1316, Section C, Electromagnetic Testing.

4. Summary of Practice

4.1 Examination is usually performed by the use of one of two general techniques:

4.1.1 *Encircling Coil Technique*—Examination is performed by passing the tube lengthwise through a coil energized with alternating current at one or more frequencies. See Fig. 1. The electrical impedance of the coil is modified by the proximity of the tube, the tube dimensions, electrical conductivity, saturating magnetic field, magnetic permeability, and metallurgical or mechanical discontinuities in the tube. As the tube passes through the coil, the changes in electromagnetic response caused by these variables in the tube change the coil impedance, which activates an audible or visual signaling device or a mechanical marker.

4.1.2 *Probe Coil Technique*—Probe coils are positioned in close proximity to the outside diameter or to the inside diameter, or to both diameter surfaces, of the tubular product being examined as shown in Fig. 1. Since the probe is generally small and does not encircle the tube, it examines only a limited area in the vicinity of the probe. When required to examine the entire volume of the tubular product, it is common practice to rotate either the tubular product or the probe around the tube. Frequently, in the case of welded tubular products, only the weld is inspected by scanning along the weld zone.

4.2 The magnetic permeability of magnetic materials severely limits the depth of penetration of induced eddy currents. Furthermore, the permeability variations inherent in magnetic tubular products can cause spurious test results. A useful solution to this problem involves the application of a strong

¹ This practice is under the jurisdiction of ASTM Committee E-7 on Nondestructive Testing and is the direct responsibility of Subcommittee E07.07 on Electromagnetic Methods.

Current edition approved Dec. 10, 1998. Published February 1999. Originally published as E 571 – 76. Last previous edition E 571 – 92.

² For ASME Boiler and Pressure Vessel Code applications see related Practice SE-571 in Section II of that Code.

³ *Annual Book of ASTM Standards*, Vol 03.03.

⁴ Available from American Society for Nondestructive Testing, 1711 Arlington Plaza, P.O. Box 28518, Columbus, OH 43228–0518.

⁵ Available from Standardization Documents Order Desk, Bldg. 4, Section D, 700 Robbins Ave., Philadelphia, PA 19111–5904, Attn: NPODS.

⁶ Available from Aerospace Industries Association of America, Inc., 1250 Eye Street, N.W., Washington, DC 20005.

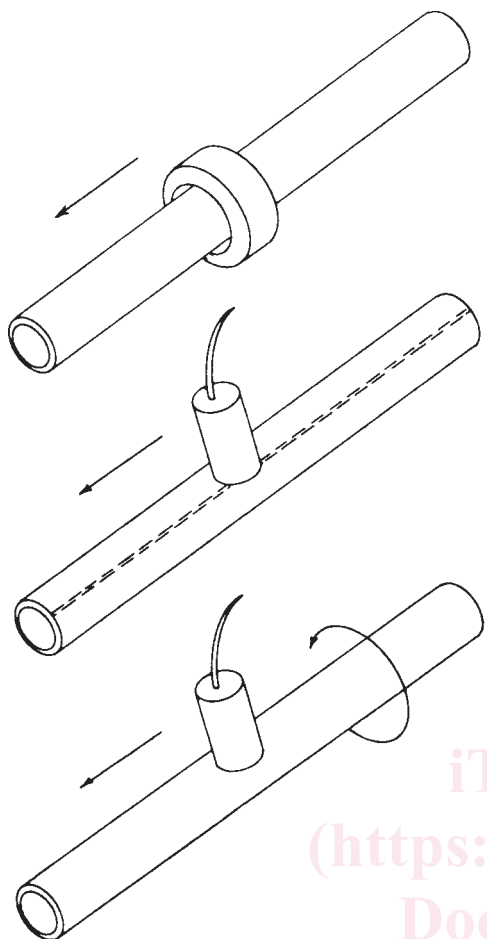

FIG. 1 Encircling-Coil and Probe-Coil Techniques for Electromagnetic Testing of Tubular Products

external magnetic field in the region of the examining coil or probe. This technique, known as magnetic saturation, causes a magnetic material to exhibit sufficiently small magnetic characteristics of permeability, hysteresis, etc., so that the material under examination is effectively rendered nonmagnetic. When achieved, this condition allows an eddy-current system to measure and detect electrical resistivity and geometrical variations (including defects) independent of concurrent variations in magnetic properties.

NOTE 2—Practice E 309 may be used for strongly magnetic materials.

4.2.1 During the testing of slightly magnetic tubing the signals resulting from the variation of magnetic permeability can mask the signals resulting from small imperfections. A magnetic saturation technique can be used to reduce this interference to an acceptable level.

5. Significance and Use

5.1 Eddy-current testing is a nondestructive method of locating discontinuities in metallic materials. Signals can be produced by discontinuities originating on either the external or internal surfaces of the tube or by discontinuities totally contained within the wall. Since the density of eddy currents decreases nearly exponentially with increasing distance from the surface nearest the coil, the response to deep-seated defects

decreases correspondingly. Phase changes are also associated with changes in depth, allowing the use of phase analysis techniques.

5.2 The response from natural discontinuities can be significantly different than that from artificial discontinuities, such as drilled holes or notches. For this reason, sufficient work should be done to establish the sensitivity level and setup required to detect natural discontinuities of consequence to the end use of the product.

5.3 Some indications obtained by this method may not be relevant to product quality; for example, an irrelevant indication may be caused by minute dents or tool chatter marks, which are not detrimental to the end use of the product. Irrelevant indications can mask unacceptable discontinuities. Relevant indications are those which result from discontinuities. Any indication that exceeds the rejection level shall be treated as a relevant indication until it can be demonstrated that it is irrelevant.

5.4 Generally, eddy-current testing systems are not sensitive to discontinuities adjacent to the ends of the tube (end effect).

5.5 Discontinuities such as scratches or seams that are continuous and uniform over the full length of the tube may not always be detected with differential encircling coils or probes scanned along the tube length.

5.6 For material that is magnetic, a strong magnetic field shall be placed in the region of the examining coil. A magnetic field may also be used to improve the signal-to-noise ratio in tubing that exhibits slight residual magnetism.

6. Basis of Application

6.1 The following criteria may be specified in the purchase specification contractual agreement, or elsewhere, and may require agreement between the purchaser and the supplier.

6.1.1 Acceptance criteria.

6.1.2 Type, dimensions, and number of artificial discontinuities to be placed in the reference standard.

6.1.3 Extent of inspection; that is, full circumference of outside or inside diameter, or both, or weld only, if welded.

6.1.4 Operator qualifications, if required.

6.1.5 Calibration intervals.

6.1.6 If specified in the contractual agreement, personnel performing examinations to this practice shall be qualified in accordance with a nationally recognized NDT personnel qualification practice or standard such as ANSI/ASNT-CP-189, SNT-TC-1A, MIL-STD-410E, NAS-410, ASNT-ACCP, or a similar document and certified by the certifying agency as applicable. The practice or standard used and its applicable revision shall be identified in the contractual agreement between the using parties.

NOTE 3—MIL-STD-410 is canceled and has been replaced with NAS-410, however, it may be used with agreement between contracting parties.

6.1.7 If specified in the contractual agreement, NDT agencies shall be qualified and evaluated in accordance with Practice E 543. The applicable edition of Practice E 543 shall be specified in the contractual agreement.

7. Apparatus

7.1 *Electronic Apparatus*—The electronic apparatus shall be capable of energizing the encircling coils or probes with