**Geotechnical investigation and
testing — Geotechnical monitoring by
field instrumentation —**

Part 5:
**Stress change measurements by total
pressure cells (TPC)**

*Reconnaissance et essais géotechniques — Surveillance géotechnique
par instrumentation in situ —*

*Partie 5: Mesures de la variation de pression par cellules de pression
totale (TPC)*

ISO 18674-5:2019

<https://standards.iteh.ai/catalog/standards/iso/95d315eb-20b3-4b8d-a519-1e0bff31c584/iso-18674-5-2019>



iTeh Standards
(<https://standards.iteh.ai>)
Document Preview

[ISO 18674-5:2019](https://standards.iteh.ai/catalog/standards/iso/95d315eb-20b3-4b8d-a519-1e0bff31c584/iso-18674-5-2019)

<https://standards.iteh.ai/catalog/standards/iso/95d315eb-20b3-4b8d-a519-1e0bff31c584/iso-18674-5-2019>



COPYRIGHT PROTECTED DOCUMENT

© ISO 2019

All rights reserved. Unless otherwise specified, or required in the context of its implementation, no part of this publication may be reproduced or utilized otherwise in any form or by any means, electronic or mechanical, including photocopying, or posting on the internet or an intranet, without prior written permission. Permission can be requested from either ISO at the address below or ISO's member body in the country of the requester.

ISO copyright office
CP 401 • Ch. de Blandonnet 8
CH-1214 Vernier, Geneva
Phone: +41 22 749 01 11
Fax: +41 22 749 09 47
Email: copyright@iso.org
Website: www.iso.org

Published in Switzerland

Contents

	Page
Foreword	iv
1 Scope	1
2 Normative references	1
3 Terms and definitions	1
4 Symbols	5
5 Instruments	6
5.1 General.....	6
5.2 Deformation measuring method.....	7
5.3 Compensation measuring method.....	7
5.4 Stiffness of the pressure compartment.....	8
5.5 Shape of the pressure compartment.....	8
5.6 Accuracy.....	9
6 Installation and measuring procedure	10
6.1 Installation.....	10
6.1.1 Installation in the ground.....	10
6.1.2 Installation in fill.....	11
6.1.3 Installation in concrete/shotcrete.....	12
6.1.4 Installation in contact planes.....	13
6.2 Carrying out the measurement.....	14
6.2.1 Instrumentation check and calibration.....	14
6.2.2 Measurement.....	14
7 Data processing and evaluation	14
8 Reporting	14
8.1 Installation report.....	14
8.2 Monitoring report.....	14
Annex A (normative) Evaluation procedure	15
Annex B (informative) Geo-engineering applications	17
Annex C (informative) Measuring examples	18
Bibliography	27

Foreword

ISO (the International Organization for Standardization) is a worldwide federation of national standards bodies (ISO member bodies). The work of preparing International Standards is normally carried out through ISO technical committees. Each member body interested in a subject for which a technical committee has been established has the right to be represented on that committee. International organizations, governmental and non-governmental, in liaison with ISO, also take part in the work. ISO collaborates closely with the International Electrotechnical Commission (IEC) on all matters of electrotechnical standardization.

The procedures used to develop this document and those intended for its further maintenance are described in the ISO/IEC Directives, Part 1. In particular, the different approval criteria needed for the different types of ISO documents should be noted. This document was drafted in accordance with the editorial rules of the ISO/IEC Directives, Part 2 (see www.iso.org/directives).

Attention is drawn to the possibility that some of the elements of this document may be the subject of patent rights. ISO shall not be held responsible for identifying any or all such patent rights. Details of any patent rights identified during the development of the document will be in the Introduction and/or on the ISO list of patent declarations received (see www.iso.org/patents).

Any trade name used in this document is information given for the convenience of users and does not constitute an endorsement.

For an explanation of the voluntary nature of standards, the meaning of ISO specific terms and expressions related to conformity assessment, as well as information about ISO's adherence to the World Trade Organization (WTO) principles in the Technical Barriers to Trade (TBT) see www.iso.org/iso/foreword.html.

This document was prepared by Technical Committee ISO/TC 182, *Geotechnics*.

A list of all parts in the ISO 18674 series can be found on the ISO website.

Any feedback or questions on this document should be directed to the user's national standards body. A complete listing of these bodies can be found at www.iso.org/members.html.

Geotechnical investigation and testing — Geotechnical monitoring by field instrumentation —

Part 5: Stress change measurements by total pressure cells (TPC)

1 Scope

This document specifies the measurement of stress changes by means of total pressure cells (TPC). General rules of performance monitoring of the ground, of structures interacting with the ground, of geotechnical fills and of geotechnical works are presented in ISO 18674-1.

If applied in conjunction with ISO 18674-4, this document allows the determination of effective stress acting in the ground.

This document is applicable to:

- monitoring changes of the state of stress in the ground and in geo-engineered structures (e.g. in earth fill dams or tunnel lining);
- monitoring contact pressures at the interface between two media (e.g. earth pressure on retaining wall; contact pressure at the base of a foundation);
- checking geotechnical designs and adjustment of construction in connection with the Observational Design procedure;
- evaluating stability during or after construction.

Guidelines for the application of TPC in geotechnical engineering are presented in [Annex B](#).

NOTE This document fulfils the requirements for the performance monitoring of the ground, of structures interacting with the ground and of geotechnical works by the means of total pressure cells as part of the geotechnical investigation and testing according to EN 1997-1^[1] and EN 1997-2^[2].

2 Normative references

The following documents are referred to in the text in such a way that some or all of their content constitutes requirements of this document. For dated references, only the edition cited applies. For undated references, the latest edition of the referenced document (including any amendments) applies.

ISO 18674-1:2015, *Geotechnical investigation and testing — Geotechnical monitoring by field instrumentation — Part 1: General rules*

ISO 18674-4, *Geotechnical investigation and testing — Geotechnical monitoring by field instrumentation — Part 4: Measurement of pore water pressure: Piezometer*

ISO 22475-1, *Geotechnical investigation and testing — Sampling methods and groundwater measurements — Part 1: Technical principles for execution*

3 Terms and definitions

For the purposes of this document, the terms and definitions given in ISO 18674-1 and the following apply.

ISO and IEC maintain terminological databases for use in standardization at the following addresses:

- ISO Online browsing platform: available at <https://www.iso.org/obp>
- IEC Electropedia: available at <http://www.electropedia.org/>

**3.1 total pressure cell
TPC**

field instrument for stress change measurements

Note 1 to entry: Typically, a total pressure cell system consists of a pressure compartment, a pressure tubing, a pressure measuring device, a measuring line and a control and readout unit (see Figure 1 and Reference [3]).

Note 2 to entry: The pressure compartment consists of two steel platens, welded together around their peripheries, where the intervening cavity is filled with a liquid. The cavity is connected to the inner chamber of a pressure measuring device via a liquid-filled pressure tubing. Inner and outer chambers of the pressure measuring device are separated by a flexible diaphragm.

Note 3 to entry: Total pressure cells are permanently installed either in fill or soft ground (*embedment pressure cells*) (3.2), in contact planes between any two media (*contact pressure cells*) (3.3) or in boreholes (*borehole pressure cells*) (3.4).

Note 4 to entry: The target of the measurement is the change of the total normal stress $\Delta\sigma_n$ of the medium acting onto the flat side of a pressure compartment (see 1 in Figure 1).

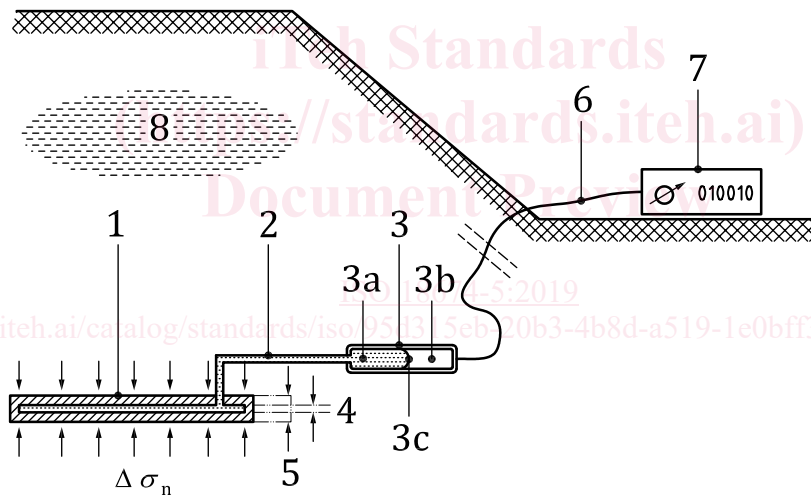

Key

- 1 pressure compartment
- 2 pressure tubing
- 3 pressure measuring device
 - 3a inner chamber
 - 3b outer chamber
 - 3c diaphragm
- 4 height of the cavity of the pressure compartment
- 5 height of the pressure compartment
- 6 measuring line (electric cable or twin hydraulic tubing)
- 7 control and readout unit
- 8 medium investigated

Figure 1 — Principal components of a TPC measuring system

3.2**embedment pressure cell**

total pressure cell (3.1) which is fully embedded within a medium

EXAMPLE Push-in cell in soft soil; “tangential cell” in shotcrete tunnel lining (see 4 in Figure 2); embedment cell in fill (see Figure 3).

3.3**contact pressure cell**

total pressure cell (3.1) which is placed in a contact plane between two media

EXAMPLE Cell at the base of a slab foundation; “radial cell” (see 3.9) in shotcrete tunnel lining.

3.4**borehole pressure cell**

total pressure cell (3.1) which is installed in a borehole

Note 1 to entry: See 2 in Figure 2.

3.5**aspect ratio**

ratio of height to the smallest lateral dimension of the pressure compartment

Note 1 to entry: For rectangular compartments, the smallest lateral dimension is the width, for circular compartments the diameter.

Note 2 to entry: Typical aspect ratios are of the order of 1:20 to 1:40.

3.6**total stress**

stress in the ground carried by the solid portion (skeleton) of the ground and the pore water

Note 1 to entry: One only stress component can be monitored by a *total pressure cell* (3.1) (which is the change of the total normal stress $\Delta\sigma_n$).

Note 2 to entry: Changes of 2-D and 3-D stress states can be monitored by a cluster of a sufficient number of independently oriented TPC compartments installed at a measuring location: Three compartments for a 2-D stress state, and six compartments for a 3-D stress state.

Note 3 to entry: By placing a TPC compartment with its sensing side towards the vertical, the vertical normal stress component σ_v can be directly monitored.

3.7**effective stress**

stress in the ground carried by the solid portion (skeleton) of the ground

Note 1 to entry: It is $\sigma' = \sigma - u$

where

σ' is the effective stress tensor;

σ is the total stress tensor;

u is the porewater pressure.

The formula above is only applicable to saturated soil.

3.8**contact stress**

stress component which acts normal to a contact plane

EXAMPLE Normal stress acting in the interface between a slab foundation and the ground.

Note 1 to entry: Shear stresses acting within the contact plane cannot be measured by a *TPC* (3.1).

3.9 radial stress

specific *contact stress* (3.8) between the ground and a tunnel lining

Note 1 to entry: Radial *TPCs* (3.1) (“radial cells”) are especially designed for monitoring radial stresses.

Note 2 to entry: See 3 in [Figure 2](#).

3.10 tangential stress

hoop stress monitored within shotcrete or concrete tunnel linings

Note 1 to entry: Tangential *TPCs* (3.1) (“tangential cells”) are especially designed for monitoring tangential stresses in tunnel linings. An alternative term is “concrete *TPC*”.

Note 2 to entry: See 4 in [Figure 2](#).

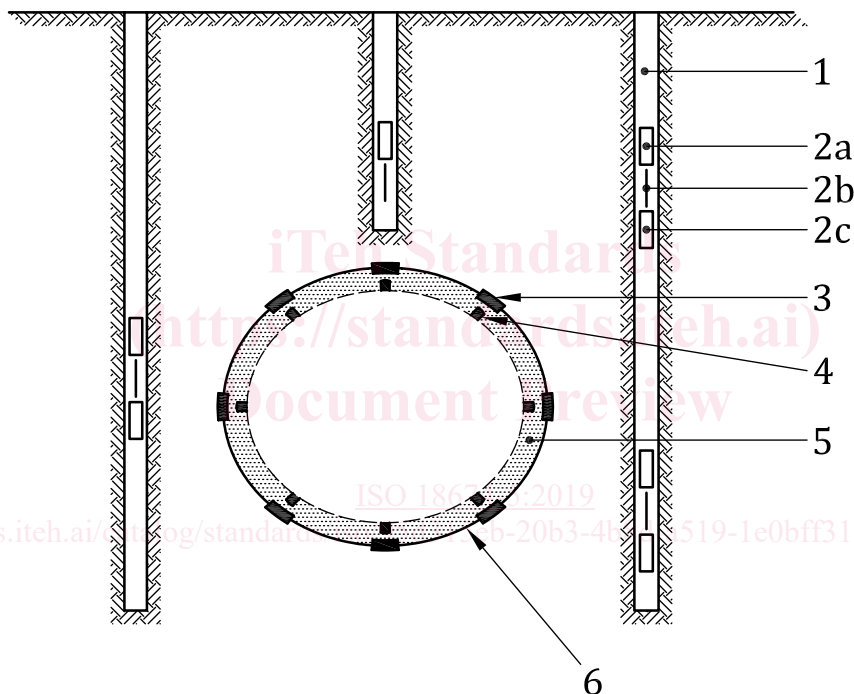

Key

- 1 borehole (vertically down-dipping; back-filled)
- 2a, 2b, 2c array of three differently oriented borehole TPCs for monitoring horizontal ground stresses
- 3 radial TPCs at the ground/shotcrete lining interface
- 4 tangential TPCs in the shotcrete lining
- 5 shotcrete lining
- 6 tunnel excavation contour

Figure 2 — Example of a TPC layout in near-surface tunnelling

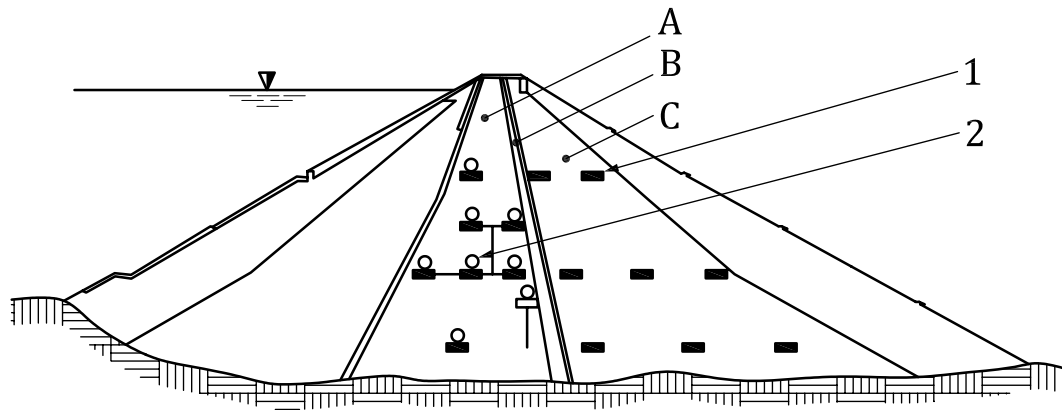
**Key**

A	clay core	1	TPC (single or cluster)
B	filter zone	2	piezometer
C	rock fill		

NOTE Zones A and C have independent cable routing systems (see 6.1.2.5).

Figure 3 — Example (schematic) of a TPC layout in an earth dam

4 Symbols

Symbol	Name	Unit
C	edge correction factor	—
E	Young's modulus	MPa
h_1	elevation of measuring station in compensation method	m
h_2	elevation of the TPC in compensation method	m
p_a	pressure in the outer chamber of the measuring device	MPa
p_F	pressure in a follow-up measurement	MPa
p_h	hydrostatic pressure difference between the external measuring station and TPC	MPa
p_i	pressure of the liquid in the compartment and in the inner chamber of the measuring device	MPa
p_L	pressure loss in the compensation delivery line	MPa
p_{p-t}	pre-tensioning pressure	MPa
p_R	pressure in reference measurement	MPa
p_{read}	pressure reading taken at the outside measuring station	MPa
u	pore water pressure	MPa
γ_{fluid}	specific weight of compensation fluid	N/m ³
$\sigma_n; \sigma_n'$	normal stress (total; effective)	MPa
$\Delta\sigma_n$	difference of total normal stress	MPa
σ_v	vertical stress	MPa
σ_H	maximum horizontal stress	MPa
σ_h	minimum horizontal stress	MPa

5 Instruments

5.1 General

5.1.1 It shall be noted that TPC measurements are prone to substantial errors as the presence of the cell in the medium tends to create significant changes in the stress field which is the target of the measurement.

NOTE 1 See [Figure 4](#) (Reference [5]).

NOTE 2 The selection of appropriate instruments, adherence to their range of application and adequate installation procedures are critical to reduce these errors to acceptable levels (see [5.4](#) and [5.6](#)).

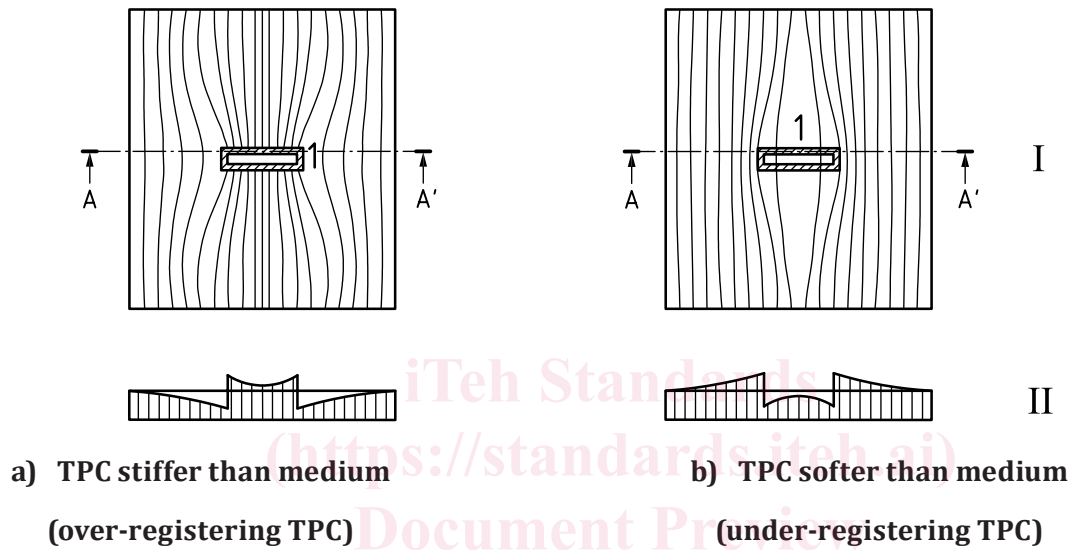

Key
 I stress trajectories around a TPC
 II normal stress profile A — A'

Figure 4 — Registering effect of embedded TPCs

5.1.2 Deformation and compensation measuring methods should be distinguished from each other (see [Table 1](#)).

Table 1 — Monitoring features associated with TPC measuring methods

Measuring method	TPC stiffness	Long-term stability of sensor signal	Atmospheric pressure compensation	Automatic data acquisition	Logging speed
Deformation (see 5.2)	tends to be soft	depends, amongst others, on the type of electrical sensors used	independent barometric pressure monitoring may be needed vented TPC tend to be unreliable	amenable	comparatively quick
Compensation (see 5.3)	tends to be stiff	tends to be long-term stable	vented TPC tend to be reliable	cumbersome; comparatively costly	comparatively slow

5.1.3 Any change of the total normal stress $\Delta\sigma_n$ acting onto the flat side of a pressure compartment (1 in [Figure 1](#)) shall be uniquely associated with a change of the pressure of the liquid in the intervening cavity of the compartment.

5.1.4 The stiffness of the pressure compartment in sensing direction should be low in comparison with the stiffness of the pressure tubing and the housing of the pressure measuring device.

5.1.5 The shape and location of the pressure measuring device shall not affect the total normal stress σ_n of the medium acting onto the pressure compartment.

NOTE A common technical solution is a TPC where the measuring device is located sufficiently far away from the pressure compartment, and where the pressure compartment and measuring device are interconnected by a stiff pressure tubing.

5.1.6 The pressure measuring device (3 in [Figure 1](#)) typically is a diaphragm pressure transducer. The cavity of the interconnected components compartment, tubing and measuring device shall be completely filled with, in engineering terms, an incompressible and de-aired liquid. The difference in elevation between compartment and measuring device should be so small that it can be neglected in the evaluation procedure (see [A.1.1](#)).

5.1.7 The housing of the pressure measuring device should be sufficiently stiff so that even high ground pressures acting onto the outer side of the device do not affect the mechanical behaviour of the diaphragm, in particular its calibration characteristics.

NOTE Experience in high embankments has shown that the earth pressure, acting on the housing of a pressure transducer, can cause a substantial shift of the zero-point and a change in the linearity of the transducer.

5.2 Deformation measuring method

5.2.1 The measurement of the deflection of the diaphragm of the pressure measuring device (see 3c in [Figure 1](#)) can be used as a method for measuring the pressure of the liquid in the intervening cavities.

NOTE Commonly, the diaphragm separating the inner chamber and outer chamber coincides with the measuring diaphragm of an electric pressure transducer.

5.2.2 The pressure in the outer chamber of the measuring device (see 3b in [Figure 1](#)) shall be either constant or atmospheric.

5.2.3 If TPC measurements are influenced by changes of the atmospheric pressure, these should be monitored separately.

NOTE Attempts to circumvent this issue by integrating a small venting tube into the measuring line (see 6 in [Figure 1](#)) are often marred with difficulties, as such tubes tend to become blocked by condensed water. This feature is in contrast to the compensation measuring method (see [5.3](#) and [Table 1](#)).

5.2.4 Deformation measurements carried out directly at the platens of the pressure compartment, e.g. by means of strain gauges or built-in vibrating wire sensors, should be avoided as this measuring procedure will typically result in compartment dimensions with high aspect ratios leading to unfavourable embedment conditions (see [6.1](#)) and ill-defined edge correction factors (see [A.1](#)).

5.3 Compensation measuring method

5.3.1 In TPC compensation measuring systems, any changes of the distance between the platens of the pressure compartment caused by $\Delta\sigma_n$ shall be compensated by an externally applied pressure p_a .

NOTE The common practice is hydraulic application of p_a at comparatively high pressure levels and pneumatic application of p_a at comparatively low pressure levels.