**Test conditions for box type vertical
drilling machines — Testing of the
accuracy**

*Condition d'essai des perceuses verticales a montant (perceuses-
aléseuses) — Contrôle de l'exactitude*

iTeh STANDARD PREVIEW
(standards.iteh.ai)

[ISO 2772:2019](https://standards.iteh.ai/catalog/standards/sist/043553f7-5b88-4e9b-8e11-341da2066b59/iso-2772-2019)

[https://standards.iteh.ai/catalog/standards/sist/043553f7-5b88-4e9b-8e11-
341da2066b59/iso-2772-2019](https://standards.iteh.ai/catalog/standards/sist/043553f7-5b88-4e9b-8e11-341da2066b59/iso-2772-2019)



iTeh STANDARD PREVIEW
(standards.iteh.ai)

ISO 2772:2019

<https://standards.iteh.ai/catalog/standards/sist/043553f7-5b88-4e9b-8e11-341da2066b59/iso-2772-2019>



COPYRIGHT PROTECTED DOCUMENT

© ISO 2019

All rights reserved. Unless otherwise specified, or required in the context of its implementation, no part of this publication may be reproduced or utilized otherwise in any form or by any means, electronic or mechanical, including photocopying, or posting on the internet or an intranet, without prior written permission. Permission can be requested from either ISO at the address below or ISO's member body in the country of the requester.

ISO copyright office
CP 401 • Ch. de Blandonnet 8
CH-1214 Vernier, Geneva
Phone: +41 22 749 01 11
Fax: +41 22 749 09 47
Email: copyright@iso.org
Website: www.iso.org

Published in Switzerland

Contents

Page

Foreword	iv
Introduction	v
1 Scope	1
2 Normative references	1
3 Terms and definitions	1
4 Terminology, designation of axes and machine configurations	2
5 Preliminary remarks	2
5.1 Measurement units.....	2
5.2 Reference to ISO 230-1 and ISO/TR 230-11.....	3
5.3 Testing sequence.....	3
5.4 Test to be performed.....	3
5.5 Measuring instruments.....	3
5.6 Minimum tolerance.....	3
5.7 Levelling.....	3
6 Test conditions and permissible deviations	4
6.1 Table.....	4
6.2 Spindle.....	5
6.3 Drilling head (Z-axis).....	7
Annex A (informative) Terms in other languages	9
Bibliography	10

[ISO 2772:2019](https://standards.iteh.ai/catalog/standards/sist/043553f7-5b88-4e9b-8e11-341da2066b59/iso-2772-2019)
<https://standards.iteh.ai/catalog/standards/sist/043553f7-5b88-4e9b-8e11-341da2066b59/iso-2772-2019>

Foreword

ISO (the International Organization for Standardization) is a worldwide federation of national standards bodies (ISO member bodies). The work of preparing International Standards is normally carried out through ISO technical committees. Each member body interested in a subject for which a technical committee has been established has the right to be represented on that committee. International organizations, governmental and non-governmental, in liaison with ISO, also take part in the work. ISO collaborates closely with the International Electrotechnical Commission (IEC) on all matters of electrotechnical standardization.

The procedures used to develop this document and those intended for its further maintenance are described in the ISO/IEC Directives, Part 1. In particular, the different approval criteria needed for the different types of ISO documents should be noted. This document was drafted in accordance with the editorial rules of the ISO/IEC Directives, Part 2 (see www.iso.org/directives).

Attention is drawn to the possibility that some of the elements of this document may be the subject of patent rights. ISO shall not be held responsible for identifying any or all such patent rights. Details of any patent rights identified during the development of the document will be in the Introduction and/or on the ISO list of patent declarations received (see www.iso.org/patents).

Any trade name used in this document is information given for the convenience of users and does not constitute an endorsement.

For an explanation of the voluntary nature of standards, the meaning of ISO specific terms and expressions related to conformity assessment, as well as information about ISO's adherence to the World Trade Organization (WTO) principles in the Technical Barriers to Trade (TBT) see www.iso.org/iso/foreword.html.

This document was prepared by Technical Committee ISO/TC 39, *Machine tools*, Subcommittee SC 2, *Test conditions for metal cutting machine tools*. ISO 2772:2019

Any feedback or questions on this document should be directed to the user's national standards body. A complete listing of these bodies can be found at www.iso.org/members.html.

This first edition of ISO 2772 cancels and replaces ISO 2772-1:1973 and ISO 2772-2:1974.

Introduction

The purpose of this document is to standardize methods of testing the accuracy of box type vertical drilling machines including geometrical tests.

iTeh STANDARD PREVIEW (standards.iteh.ai)

[ISO 2772:2019](https://standards.iteh.ai/catalog/standards/sist/043553f7-5b88-4e9b-8e11-341da2066b59/iso-2772-2019)

<https://standards.iteh.ai/catalog/standards/sist/043553f7-5b88-4e9b-8e11-341da2066b59/iso-2772-2019>

iTeh STANDARD PREVIEW
(standards.iteh.ai)

ISO 2772:2019

<https://standards.iteh.ai/catalog/standards/sist/043553f7-5b88-4e9b-8e11-341da2066b59/iso-2772-2019>

Test conditions for box type vertical drilling machines — Testing of the accuracy

1 Scope

This document specifies, with reference to ISO 230-1, geometrical tests on general purpose and normal accuracy box type vertical drilling machines. It also specifies the applicable tolerances corresponding to the above-mentioned tests.

This document deals only with the verification of accuracy of the machine.

It does not apply to the testing of the machine operation (vibrations, abnormal noises, stick-slip motion of components, etc.) or to machine characteristics (such as speeds, feeds, etc.), which are generally checked before testing of machine accuracy.

2 Normative references

The following documents are referred to in the text in such a way that some or all of their content constitutes requirements of this document. For dated references, only the edition cited applies. For undated references, the latest edition of the referenced document (including any amendments) applies.

ISO 230-1:2012, *Test code for machine tools — Part 1: Geometric accuracy of machines operating under no-load or quasi-static conditions*

ISO/TR 230-11:2018, *Test code for machine tools — Part 11: Measuring instruments suitable for machine tool geometry tests* <https://standards.iteh.ai/catalog/standards/sist/043553f7-5b88-4e9b-8e11-341da2066b59/iso-2772-2019>

3 Terms and definitions

For the purposes of this document, the terms and definitions given in ISO 230-1 and the following apply.

ISO and IEC maintain terminological databases for use in standardization at the following addresses:

- ISO Online browsing platform: available at <https://www.iso.org/obp>
- IEC Electropedia: available at <http://www.electropedia.org/>

3.1 drilling

producing holes in cold metal by the use of a rotating cutting tool

3.2 drilling machine

machine designed to produce holes in cold metal by the use of a rotating cutting tool

[SOURCE: EN 12717:2009, 3.1]

3.3 manual drilling machine

machine designed to produce holes in cold metal by the use of a rotating cutting tool where the axial motion of the cutting tool is controlled through the actuation of a handwheel or lever

Note 1 to entry: The handwheel or lever can include powered axial feed or powered unprogrammed positioning of spindle or workpiece.

3.4 box type vertical drilling machine

drilling machine in which vertical motion of the drilling head is guided on a box-shape column with parallel slideways

4 Terminology, designation of axes and machine configurations

For the nomenclature and terminology of a box type vertical manual drilling machine, see [Figure 1](#).

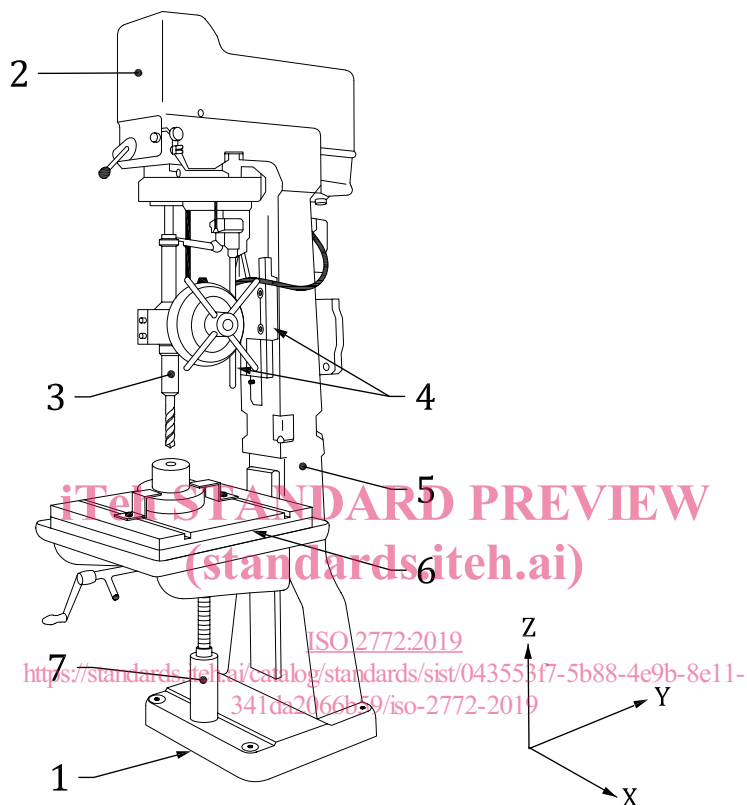

Key

English	French
1 base	socle
2 drilling head (Z-axis)	tête de perçage (axe Z)
3 spindle	broche
4 slideways	glissières
5 column	colonne
6 table (W-axis)	table (axe W)
7 table height adjuster	réglage de la table en hauteur

NOTE For languages other than official ISO languages, see [Table A.1](#).

Figure 1 — Example of a box type vertical manual drilling machine

5 Preliminary remarks

5.1 Measurement units

In this document, all linear dimensions, deviations and corresponding tolerances are expressed in millimetres (mm); angular dimensions are expressed in degrees (°), and angular deviations and the

corresponding tolerances are expressed in ratios. In some cases, microradians (μrad) or arcseconds (") may be used for clarification purposes. Formula (1) should always be kept in mind:

$$0,010 / 1\ 000 = 10\ \mu\text{rad} \approx 2'' \quad (1)$$

5.2 Reference to ISO 230-1 and ISO/TR 230-11

To apply this document, reference shall be made to ISO 230-1, especially for the installation of the machine before testing, the warming up of spindles and other moving components, description of measuring methods and recommended accuracy of the test equipment.

Where the test concerned is in compliance with the specifications of ISO 230-1, a reference to the corresponding subclause of ISO 230-1 is shown before the instructions in the "Observations" block of the tests described in [Clauses 5](#) and [6](#).

5.3 Testing sequence

The sequence in which the tests are presented in this document in no way defines the practical order of testing. In order to make the mounting of instruments or gauging easier, tests may be performed in any order.

5.4 Test to be performed

When testing a machine, it is not always necessary or possible to carry out all the tests described in this document. When the tests are required for acceptance purposes, it is up to the user to choose, in agreement with the supplier/manufacturer, the relevant tests relating to the components and/or the properties of the machine which are of interest. These tests are to be clearly stated when ordering a machine. A simple reference to this document for the acceptance tests, without specifying the tests to be carried out or without agreement on the relevant expenses, cannot be considered as an agreement between manufacturer/supplier and user.

5.5 Measuring instruments

Measuring instruments indicated in the tests described below are only examples. Other instruments capable of measuring the same quantities and having the same, or a smaller, measurement uncertainty may be used. Reference shall be made to ISO 230-1:2012, Clause 5, which indicates the relationship between measurement uncertainties and the tolerances.

5.6 Minimum tolerance

When establishing the tolerance for a measuring length different from that given in this document (see ISO 230-1:2012, 4.1), it shall be taken into consideration that the minimum value of tolerance is 0,010 mm.

5.7 Levelling

Prior to conducting tests on a box type vertical drilling machine, the machine should be levelled according to the recommendations of the manufacturer/supplier (see ISO 230-1:2012, 6.1.2).