



Designation: ~~F773M-96 (Reapproved 2003)~~ Designation: F773M - 10

Standard Practice for Measuring Dose Rate Response of Linear Integrated Circuits (Metric)¹

This standard is issued under the fixed designation F773M; the number immediately following the designation indicates the year of original adoption or, in the case of revision, the year of last revision. A number in parentheses indicates the year of last reapproval. A superscript epsilon (ϵ) indicates an editorial change since the last revision or reapproval.

1. Scope

1.1 This practice covers the measurement of the response of linear integrated circuits, under given operating conditions, to pulsed ionizing radiation. The response may be either transient or more lasting, such as latchup. The radiation source is either a flash X-ray machine (FXR) or an electron linear accelerator (LINAC).

1.2 The precision of the measurement depends on the homogeneity of the radiation field and on the precision of the radiation dosimetry and the recording instrumentation.

1.3 The test may be considered to be destructive either for further tests or for other purposes if the total radiation ionizing dose exceeds some predetermined level or if the part should latch up. Because this level depends both on the kind of integrated circuit and on the application, a specific value must be agreed upon by the parties to the test. (See 6.10.)

1.4 Setup, calibration, and test circuit evaluation procedures are included in this practice.

1.5 Procedures for lot qualification and sampling are not included in this practice.

1.6 Because response varies with different device types, the dose rate range for any specific test is not given in this practice but must be agreed upon by the parties to the test.

~~1.7~~

1.7 The values stated in SI units are to be regarded as standard. No other units of measurement are included in this standard.

1.8 This standard does not purport to address all of the safety concerns, if any, associated with its use. It is the responsibility of the user of this standard to establish appropriate safety and health practices and determine the applicability of regulatory limitations prior to use.

2. Referenced Documents

2.1 *ASTM Standards:*²

E666 [Practice for Calculating Absorbed Dose From Gamma or X Radiation](#)

E668 [Practice for Application of Thermoluminescence-Dosimetry \(TLD\) Systems for Determining Absorbed Dose in Radiation-Hardness Testing of Electronic Devices](#)

E1894 [Guide for Selecting Dosimetry Systems for Application in Pulsed X-Ray Sources](#)

F526 [Test Method for Measuring Dose for Use in Linear Accelerator Pulsed Radiation Effects Tests](#)

3. Terminology

3.1 *Definitions:*

3.1.1 *dose rate*—energy absorbed per unit time and per unit mass by a given material from the radiation to which it is exposed.

3.1.2 *dose rate induced latchup*—Regenerative device action in which a parasitic region (e.g., a four (4) layer p-n-p-n or n-p-n-p path) is turned on by a photocurrent generated by a pulse of ionizing radiation and remains on for an indefinite period of time after the photocurrent subsides. The device will remain latched as long as the power supply delivers voltage greater than the holding voltage and current greater than the holding current. Latchup may disrupt normal circuit operation in some portion of the circuits, and may also cause catastrophic failure due to local heating of semiconductor regions, metallizations or bond wires.

3.1.2.1 Discussion—Latchup is very sensitive at higher voltages and maximum voltage. The observance of latchup will be seen readily if these operation conditions are achieved.

¹ This practice is under the jurisdiction of ASTM Committee F01 on Electronics and is the direct responsibility of Subcommittee F01.11 on Nuclear and Space Radiation Effects.

~~Current edition approved June 10, 2003. Published June 2003. Originally approved in 1982. Last previous edition approved in 1996 as F773M-96. DOI: 10.1520/F0773M-96R03.~~

Current edition approved May 1, 2010. Published June 2010. Originally approved in 1982. Last previous edition approved in 2003 as F773M-96 (2003). DOI: 10.1520/F0773M-10.

² For referenced ASTM standards, visit the ASTM website, www.astm.org, or contact ASTM Customer Service at service@astm.org. For *Annual Book of ASTM Standards* volume information, refer to the standard's Document Summary page on the ASTM website.

3.1.3 *dose rate response*—the change that occurs in an observed characteristic of an operating linear integrated circuit induced by a radiation pulse of a given dose rate.

3.1.4 *latchup window*—A latchup window is the phenomenon in which a device exhibits latchup in a specific range of dose rates. Above and below this range, the device does not latchup. A device may exhibit more than one latchup window. This phenomenon has been observed for some complimentary metal-oxide-semiconductor (CMOS) logic devices, oxide sidewall logic and large scale integration (LSI) memories and may occur in the other devices.

3.1.5 *upset threshold*—The minimum dose rate at which the device upsets. However, the reported measured upset threshold shall be the maximum dose rate at which the device does not upset and which the transient disturbance of the output waveform and or supply current remains within the specified limits.

4. Summary of Practice

4.1 The test device and suitable dosimeters are irradiated by a pulse from either an FXR or a LINAC while the test device is operating under agreed-upon conditions. The responses of the test device and of the dosimeters are recorded.

4.2 The response of the test device to dose rate is recorded over a specified dose rate range.

4.3 A number of factors are not defined in this practice, and must be agreed upon beforehand by the parties to the test.

4.3.1 Total dose limit (see 1.3),

4.3.2 Electrical parameters of the test device whose responses are to be measured (see 10.10),

4.3.3 Temperature at which the test is to be performed (see 6.7),

4.3.4 Details of the test circuit, including output loading, power supply levels, and other operating conditions (see 7.4 and 10.3),

4.3.5 Choice of radiation pulse source (see 6.9 and 7.9),

4.3.6 Pulse width (see 6.9 and 7.9.2),

4.3.7 Sampling (see 8.1),

4.3.8 Need for total ionizing dose measurement (see 6.10, 7.8, and 10.1.1),

4.3.9 An irradiation plan which includes the dose rate range and the minimum number of dose rate values to be used in that range (see 10.6 and 10.9), and

4.3.10 Appropriate functional test (see 10.4 and 10.8).

5. Significance and Use

5.1 There are many kinds of linear integrated circuits. Any given linear integrated circuit may be used in a variety of ways and under various operating conditions within the limits of performance specified by the manufacturer. The procedures of this practice provide a standardized way to measure the dose-rate response of a linear integrated circuit, under operating conditions similar to those of the intended application, when the circuit is exposed to pulsed ionizing radiation.

5.2 Knowledge of the responses of linear integrated circuits to radiation pulses is essential for the design, production, and maintenance of electronic systems that are required to operate in the presence of pulsed radiation environments.

6. Interferences

6.1 *Air Ionization*—A spurious component of the signal measured during a test can result from conduction through air ionized by the radiation pulse. Such spurious contributions can be checked by measuring the signal while irradiating the test fixture in the absence of a test device. Air ionization contributions to the observed signal are generally proportional to applied field, while those due to secondary emission effects (6.2) are not. The effects of air ionization external to the device may be minimized by coating exposed leads with a thick layer of paraffin, silicone rubber, or nonconductive enamel, or by making the measurement in a vacuum.

6.2 *Secondary Emission*—Another spurious component of the measured signal can result from charge emission from, or charge injection into, the test device and test circuit.³ This may be minimized by shielding the surrounding circuitry and irradiating only the minimum area necessary to ensure irradiation of the test device. Reasonable estimates of the expected magnitude of current resulting from secondary-emission effects can be made based on the area of metallic target materials irradiated.

NOTE 1—For dose rates in excess of 10^8 Gy (Si)/s, the photocurrents developed by the package may dominate the device photocurrent. Care should be taken in the interpretation of the measured photoresponse for these high dose rates.

Values of current density per unit dose rate generally range between 10^{-11} and 10^{-10} A/cm² per Gy(Si)/s. The use of a scatter plate (7.9.2) may increase these values.

6.3 *Orientation*—The effective ionizing dose to a semiconductor junction can be altered by changing the orientation of the test device with respect to the irradiating beam. Most integrated circuits may be considered “thin samples” (in terms of the range of the radiation). However, some devices may have cooling studs or thick-walled cases that can act to scatter the incident beam, thereby modifying the dose received by the semiconductor chip. Position such devices carefully with the die normal to the beam.

6.4 *Dose Enhancement*—High atomic number materials near the active regions of the integrated circuit (package, metallization, die attach materials, etc.) can deliver an enhanced dose to the sensitive regions of the device due to secondary electron emission from the high atomic number material when it is irradiated with an FXR. The possibility and extent of this effect should be considered.

³ Sawyer, J. A., and van Lint, V. A. J., “Calculations of High-Energy Secondary Electron Emission,” *Journal of Applied Physics*, Vol 35, No. 6, June 1964, pp. 1706–1711.

6.5 *Electrical Noise*—Since radiation test facilities are inherent sources of r-f noise, good noise-minimizing techniques such as single-point ground, filtered dc supply lines, etc., must be used in these measurements (see Fig. 1).

6.6 *Dosimetry*—Accurate, reproducible calibration of dose-rate monitors is difficult. For this reason, dosimetry is apt to provide the single most substantial source of error in dose-rate determinations.

6.7 *Temperature*—~~Device characteristics are dependent on junction temperature; hence, the temperature of the test should be controlled. Unless otherwise agreed upon by the parties to the test, measurements will be made at room temperature ($23 \pm 5^\circ\text{C}$).~~ Device characteristics are dependent on junction temperature; hence, the temperature of the test should be controlled. Unless otherwise agreed upon by the parties to the test, dose rate testing shall be performed at $24 \pm 6^\circ\text{C}$. (Temperature should be specified in the test plan or test procedure).

6.8 *Beam Homogeneity and Pulse-to-Pulse Repeatability*—The intensity of a beam from an FXR or a LINAC is likely to vary across its cross section. Since the pulse-shape monitor is placed at a different location than the device under test, the measured dose rate may be different from the dose rate to which the device was exposed. The spatial distribution and intensity of the beam may also vary from pulse to pulse. The beam homogeneity and pulse-to-pulse repeatability associated with a particular radiation source should be established by a thorough characterization of its beam prior to performing a measurement.

6.9 *Pulse Width*—The response observed in a dose rate test may be dependent on the width of the radiation pulse. This fact must be considered when selecting a radiation source, or when comparing data taken at different times or at different radiation test facilities.

6.10 *Total Ionizing Dose*—Each pulse of the radiation source imparts an ionizing dose to both the device under test and the device used for dosimetry. The total ionizing dose accumulated in a semiconductor device will cause permanent damage which can change its operating characteristics. As a result, the response that is measured after several pulses may be different from that characteristic of an unirradiated device. Care should be exercised to ensure that the total ionizing dose delivered to the test device is less than the agreed-upon maximum value. Care must also be taken to ensure that the characteristics of the dosimeter have not changed due to the accumulated dose.

7. Apparatus

7.1 *Regulated DC Power Supplies* with floating outputs to produce the voltages required to bias the integrated circuit under test.

7.2 *Recording Devices*, such as oscilloscopes equipped with cameras, transient digitizers with appropriate displays, or other suitable instruments. The bandwidth capabilities of the recording devices shall be such that the radiation responses of the integrated circuit and the pulse-shape monitor (7.6) are accurately displayed and recorded.

NOTE 2—Depending on the kind of measurement, dc instruments, spectrum analyzers, current transformers, or other instruments may be required to measure and record the response of the test device.

7.3 *Cabling* to complete adequately the connection of the test circuit in the exposure area with the power supply and recording devices in the data area. Shielded twisted pair or coaxial cables may be used to connect the power supplies to the bias points of the test circuit; however, coaxial cables properly terminated at the recording device inputs are required for the signal leads.

7.4 *Test Circuit*, as shown in Fig. 1. Although the details of test circuits for this test must vary depending on the kind of electronic component tested and on the specific electrical parameters of the test device to be measured, the example of Fig. 1

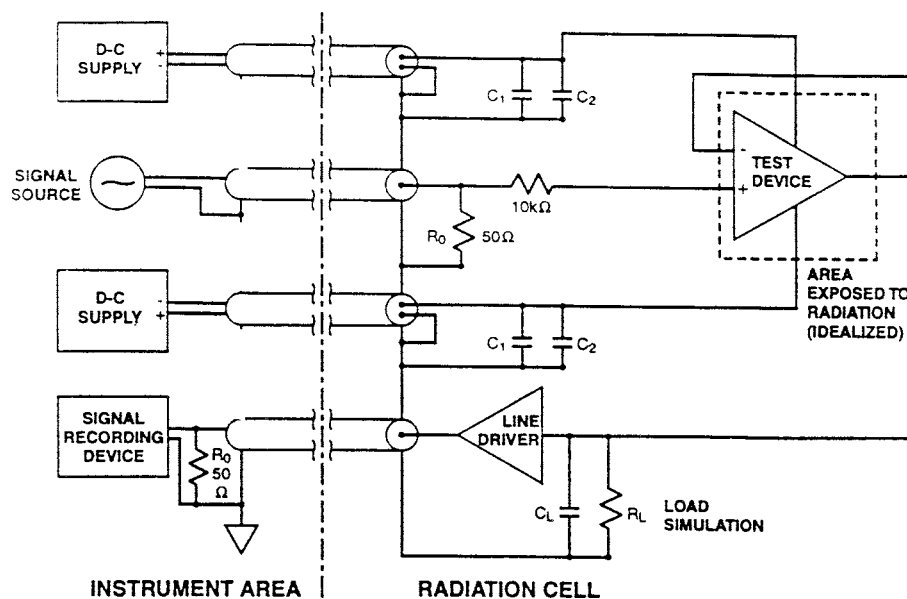

FIG. 1 Example of a Test Circuit