Paints and varnishes — Determination of flow time by use of flow cups

*Peintures et vernis — Détermination du temps d'écoulement au
moyen de coupes d'écoulement*

iTeh STANDARD PREVIEW
(standards.iteh.ai)

[ISO 2431:2019](https://standards.iteh.ai/catalog/standards/sist/880a209e-fa6b-48e8-a005-a8a4ef060552/iso-2431-2019)

<https://standards.iteh.ai/catalog/standards/sist/880a209e-fa6b-48e8-a005-a8a4ef060552/iso-2431-2019>



iTeh STANDARD PREVIEW
(standards.iteh.ai)

ISO 2431:2019

<https://standards.iteh.ai/catalog/standards/sist/880a209e-fa6b-48e8-a005-a8a4ef060552/iso-2431-2019>



COPYRIGHT PROTECTED DOCUMENT

© ISO 2019

All rights reserved. Unless otherwise specified, or required in the context of its implementation, no part of this publication may be reproduced or utilized otherwise in any form or by any means, electronic or mechanical, including photocopying, or posting on the internet or an intranet, without prior written permission. Permission can be requested from either ISO at the address below or ISO's member body in the country of the requester.

ISO copyright office
CP 401 • Ch. de Blandonnet 8
CH-1214 Vernier, Geneva
Phone: +41 22 749 01 11
Fax: +41 22 749 09 47
Email: copyright@iso.org
Website: www.iso.org

Published in Switzerland

Contents

Page

Foreword	iv
Introduction	v
1 Scope	1
2 Normative references	1
3 Terms and definitions	1
4 Temperature considerations	2
5 Apparatus	2
5.1 Flow cups.....	2
5.1.1 Dimensions.....	2
5.1.2 Material.....	2
5.1.3 Construction.....	2
5.1.4 Finish.....	3
5.1.5 Measurement range.....	4
5.1.6 Marking.....	5
5.1.7 Care and checking of flow cups.....	5
5.2 Supplementary apparatus.....	6
6 Sampling	6
7 Procedure	6
7.1 Preliminary check for Newtonian flow.....	6
7.2 Determination of flow time.....	6
7.2.1 Choice of flow cup.....	6
7.2.2 Temperature adjustment.....	6
7.2.3 Preparation of the flow cup.....	7
7.2.4 Filling the flow cup.....	7
7.2.5 Measurement of flow time.....	7
7.2.6 Repeat determinations.....	7
8 Marking of products tested	7
9 Precision	8
9.1 General.....	8
9.2 Repeatability limit, r	8
9.3 Reproducibility limit, R	8
10 Test report	9
Annex A (normative) Checking flow cups for wear and tear	10
Annex B (informative) Conversion of flow times from one temperature to another	12
Bibliography	14

Foreword

ISO (the International Organization for Standardization) is a worldwide federation of national standards bodies (ISO member bodies). The work of preparing International Standards is normally carried out through ISO technical committees. Each member body interested in a subject for which a technical committee has been established has the right to be represented on that committee. International organizations, governmental and non-governmental, in liaison with ISO, also take part in the work. ISO collaborates closely with the International Electrotechnical Commission (IEC) on all matters of electrotechnical standardization.

The procedures used to develop this document and those intended for its further maintenance are described in the ISO/IEC Directives, Part 1. In particular, the different approval criteria needed for the different types of ISO documents should be noted. This document was drafted in accordance with the editorial rules of the ISO/IEC Directives, Part 2 (see www.iso.org/directives).

Attention is drawn to the possibility that some of the elements of this document may be the subject of patent rights. ISO shall not be held responsible for identifying any or all such patent rights. Details of any patent rights identified during the development of the document will be in the Introduction and/or on the ISO list of patent declarations received (see www.iso.org/patents).

Any trade name used in this document is information given for the convenience of users and does not constitute an endorsement.

For an explanation of the voluntary nature of standards, the meaning of ISO specific terms and expressions related to conformity assessment, as well as information about ISO's adherence to the World Trade Organization (WTO) principles in the Technical Barriers to Trade (TBT) see www.iso.org/iso/foreword.html.

This document was prepared by Technical Committee ISO/TC 35, *Paints and varnishes*, Subcommittee SC 9, *General test methods for paints and varnishes*.

This sixth edition cancels and replaces the fifth edition (ISO 2431:2011), which has been technically revised. The main changes compared to the previous edition are as follows:

- a general reference to ISO 4618 has been added in [Clause 3](#);
- the information in [Clause 4](#) on measuring at other temperatures and humidities specified in this document has been amended;
- [Figure 1](#) has been corrected;
- information on conduction of measurements in a fume cupboard has been added to [Clause 4](#).

Any feedback or questions on this document should be directed to the user's national standards body. A complete listing of these bodies can be found at www.iso.org/members.html.

This corrected version of ISO 2431:2019 incorporates the following correction:

- In [Table 1](#), the formula for calculating the kinematic viscosity, ν , of flow cup No 5 was corrected to

$$\text{read: } \nu = 3,28 \times t - \frac{220}{t}.$$

Introduction

The first edition of this document, ISO 2431, published in 1972, specified only one flow cup with an orifice diameter of 4 mm. The second edition specified three flow cups with an orifice diameter of 3 mm, 4 mm and 6 mm. The third edition corrected errors in Figures 2 and 4 and the formulae for those figures. The fourth edition specified four flow cups with an orifice diameter of 3 mm, 4 mm, 5 mm and 6 mm. In the fifth edition the curves in Figures 2 to 5 have been placed in a single figure ([Figure 2](#)) and the formulae for the conversion of flow time to kinematic viscosity and vice versa represented by the curves in these figures have been moved from the figures to a table ([Table 1](#)). The procedure for checking the flow cups for wear and tear has been revised to include two alternative methods (one using a certified reference material or secondary working standard, the other using a certified flow cup) and has been moved to an informative annex. The main changes made in this sixth edition are given in the foreword.

As is well known, many countries over the years have developed their own standard flow cups and the difficulty in correlation between them has led to considerable confusion in comparing values. The standardization of an improved design of flow cup has been recommended after careful consideration of the role of flow cups for the measurement of the flow time of paints, varnishes and related products.

Flow times are a measure for sample viscosity only for products with Newtonian or near-Newtonian flow properties. This effectively limits the practical use of flow cups. Nevertheless, for checking purposes, these flow cups do serve a useful purpose. Furthermore, the measurement of flow time is often used to confirm the application consistency.

Paints often contain thickening agents to ensure increased viscosity. Such paints exhibit non-Newtonian flow properties. Their viscosity during application can only be properly assessed using viscometers such as that described in ISO 3219.

Resins and varnishes can exhibit Newtonian or near-Newtonian flow at much higher viscosities than most paints and, where this applies, flow cups can provide a useful means of controlling the consistency. As a result, this document provides flow cups suitable for viscosities up to about 700 mm²/s.

With thixotropic materials, stirring or other such mechanical stress immediately before testing will reduce the flow time compared with that for an unstirred sample. With such materials, uncertain and variable flow time values are obtained with all the flow cups. The repeatability and reproducibility limits given in [Clause 9](#) cannot be achieved in the determination of the flow time of such materials.

iTeh STANDARD PREVIEW
(standards.iteh.ai)

ISO 2431:2019

<https://standards.iteh.ai/catalog/standards/sist/880a209e-fa6b-48e8-a005-a8a4ef060552/iso-2431-2019>

Paints and varnishes — Determination of flow time by use of flow cups

1 Scope

This document specifies a method for determining the flow time of paints, varnishes and related products that can be used to control consistency.

Four flow cups of similar dimensions, but having orifice diameters of 3 mm, 4 mm, 5 mm and 6 mm, are specified. Two methods for checking the flow cups for wear and tear are given (see [Annex A](#)).

Flow cups with a replaceable jet are not covered by this document as the close tolerances on the supply of the material under test to the jet are not met.

Commonly used dipping flow cups are also not covered by this document.

NOTE Since the fabrication tolerances for such flow cups are greater than those of the flow cups specified in this document, flow time determinations with dipping flow cups give a precision which is lower than that obtained with the flow cups specified in this document (see [Clause 9](#)).

The method described in this document is limited to testing materials for which the breakpoint of the flow from the orifice of the flow cup can be determined with certainty. This point is difficult to determine and reproduce for materials with flow times near the upper limit of the measurement range (100 s) due to slowing-down effects.

2 Normative references

ISO 2431:2019

<https://standards.iteh.ai/catalog/standards/sist/880a209e-fa6b-48e8-a005-a8a4ef060552/iso-2431-2019>

The following documents are referred to in the text in such a way that some or all of their content constitutes requirements of this document. For dated references, only the edition cited applies. For undated references, the latest edition of the referenced document (including any amendments) applies.

ISO 1513, *Paints and varnishes — Examination and preparation of test samples*

ISO 4618, *Paints and varnishes — Terms and definitions*

ISO 15528, *Paints, varnishes and raw materials for paints and varnishes — Sampling*

3 Terms and definitions

For the purposes of this document, the terms and definitions given in ISO 4618 and the following apply.

ISO and IEC maintain terminological databases for use in standardization at the following addresses:

— ISO Online browsing platform: available at <https://www.iso.org/obp>

— IEC Electropedia: available at <http://www.electropedia.org/>

3.1

flow time

t

time that elapses from the moment when the material under test starts to flow from the orifice of the filled flow cup to the moment when the flow stream of material first breaks off close to the orifice

3.2

Newtonian flow

behaviour where the shear viscosity is independent of shear rate, shear stress and time

3.3

non-Newtonian flow

behaviour where the shear viscosity is dependent either on shear rate and shear stress or on shear rate, shear stress and time

3.4

kinematic viscosity

ν

ratio of shear viscosity and density

Note 1 to entry: The kinematic viscosity ν has the unit square metres per second ($\text{m}^2\cdot\text{s}^{-1}$).

4 Temperature considerations

Temperature and humidity are important parameters affecting test results. Deviations from the requirements specified can lead to results that are not comparable. However, the interested parties may agree upon alternative parameters and these parameters shall be reported.

The effect of temperature on flow time is highly significant with respect to application properties and varies with the type of product.

For reference purposes, $(23,0 \pm 0,5)^\circ\text{C}$ is specified as the test temperature in this document. However, it might be more convenient to carry out comparative testing at some other agreed temperature (for example, 25°C) because of prevailing temperature conditions (see also [Annex B](#)).

For control by flow time, the test sample and flow cup shall be conditioned to an agreed or specified temperature and it shall be ensured that the temperature variation does not exceed 0,5 K during testing. The flow cup shall be in a place which is free from draughts.

If testing is conducted in a fume cupboard and the air suction is left on, this shall be noted in the test report.

5 Apparatus

5.1 Flow cups

5.1.1 Dimensions

The dimensions of the ISO flow cups and the tolerances allowed in manufacture shall be as shown in [Figure 1](#).

NOTE The most critical tolerance is the internal diameter of the jet of the flow cup, because the flow time is inversely proportional to the fourth power of this dimension.

5.1.2 Material

The jet of the flow cup shall be made of stainless steel or sintered carbide, and the body of the flow cup shall be made of a material which is corrosion-resistant and is not affected by the products to be tested.

5.1.3 Construction

The dimensions not specified, such as wall thickness, shall be such that no distortion of the flow cup can occur in use. The external shape should preferably be as shown in [Figure 1](#), but may be modified for convenience of use, or manufacture, provided that the protruding jet of the flow cup is protected from

accidental damage as far as possible by an external protective sleeve. Such a protective sleeve shall not be immediately adjacent to the jet, so as to prevent any capillary action when the material under test flows out.

Flow cups having an additional jacket for temperature control are preferred.

5.1.4 Finish

The interior surfaces of the flow cups, including the orifice, shall be smooth and free from turning marks, crevices, ledges and burrs which might cause random flow or trap sample or cleaning material.

The standard of finish required is equivalent to a maximum roughness Ra (as defined in ISO 4287) of not more than 0,5 µm.

Dimensions in millimetres
Roughness in micrometres

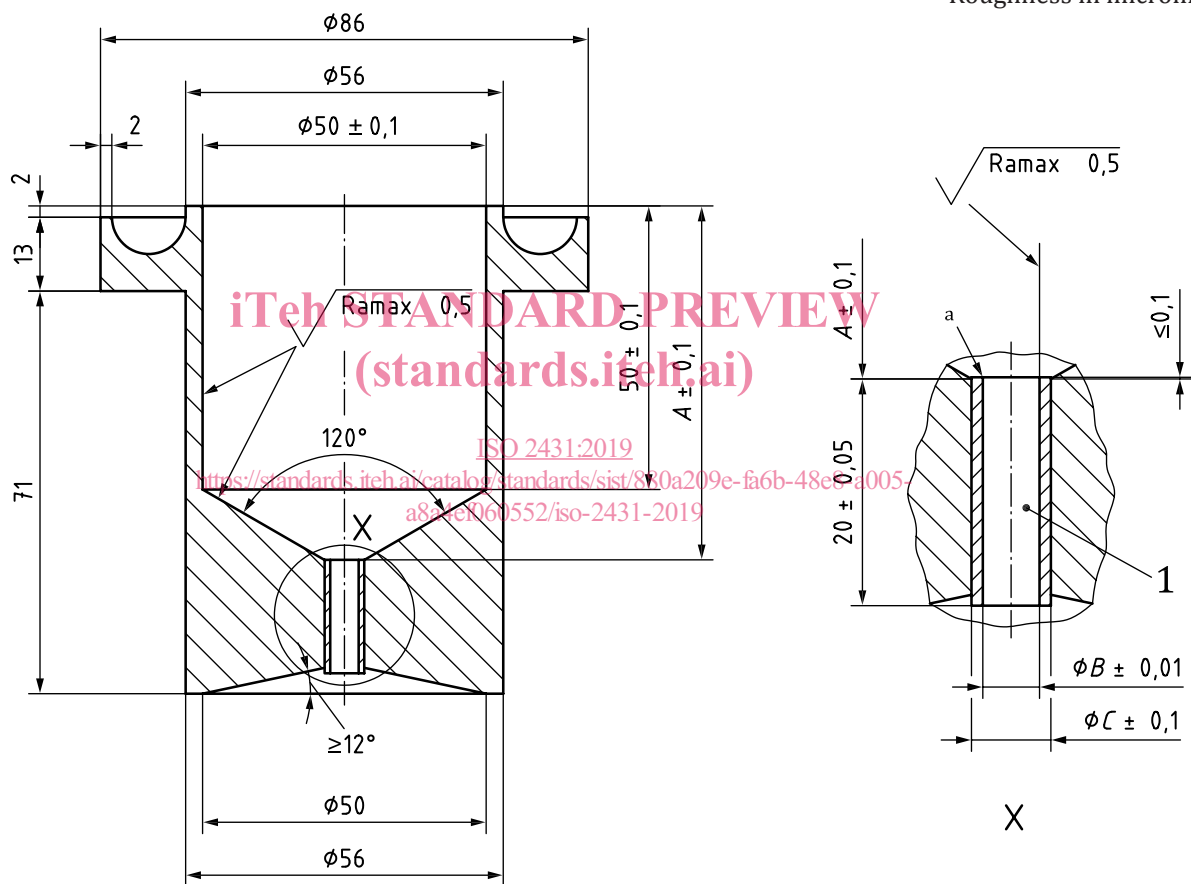

Key

- 1 jet
- a Sharp edge (not rounded).

Dimension	Values ^b for the flow cups given			
	3-mm (No 3) flow cup	4-mm (No 4) flow cup	5-mm (No 5) flow cup	6-mm (No 6) flow cup
A	63	62,7	62,4	62,1
B	3	4	5	6
C	5	6	7	8

^b For tolerances, see the enlarged section of the jet.

Figure 1 — Flow cup

5.1.5 Measurement range

Flow cups shall be used within the measurement range given in [Table 1](#). Meaningful data can only be obtained in this range. In addition, the conversion of flow time to kinematic viscosity and *vice versa*, shall be carried out using the formulae given in [Table 1](#).

Table 1 — Measurement range of flow cups and conversion of flow time to kinematic viscosity and *vice versa*

Flow cup	Flow time, t s	Kinematic viscosity, ν mm ² /s	Measurement range s
No 3	$t = \frac{\nu}{0,89} + \sqrt{451,5 + \left(\frac{\nu}{0,89}\right)^2}$	$\nu = 0,443 \times t - \frac{200}{t}$	$30 \leq t \leq 100$
No 4	$t = \frac{\nu}{2,74} + \sqrt{146,0 + \left(\frac{\nu}{2,74}\right)^2}$	$\nu = 1,37 \times t - \frac{200}{t}$	$30 \leq t \leq 100$
No 5	$t = \frac{\nu}{6,56} + \sqrt{67,1 + \left(\frac{\nu}{6,56}\right)^2}$	$\nu = 3,28 \times t - \frac{220}{t}$	$30 \leq t \leq 100$
No 6	$t = \frac{\nu}{13,8} + \sqrt{82,6 + \left(\frac{\nu}{13,8}\right)^2}$	$\nu = 6,90 \times t - \frac{570}{t}$	$30 \leq t \leq 100$

The curves corresponding to the formulae given in [Table 1](#) are plotted in [Figure 2](#).

NOTE These curves are given for information only.
<https://standards.iteh.ai/catalog/standards/sist/880a209e-fa6b-48e8-a005-a8a4ef060552/iso-2431-2019>

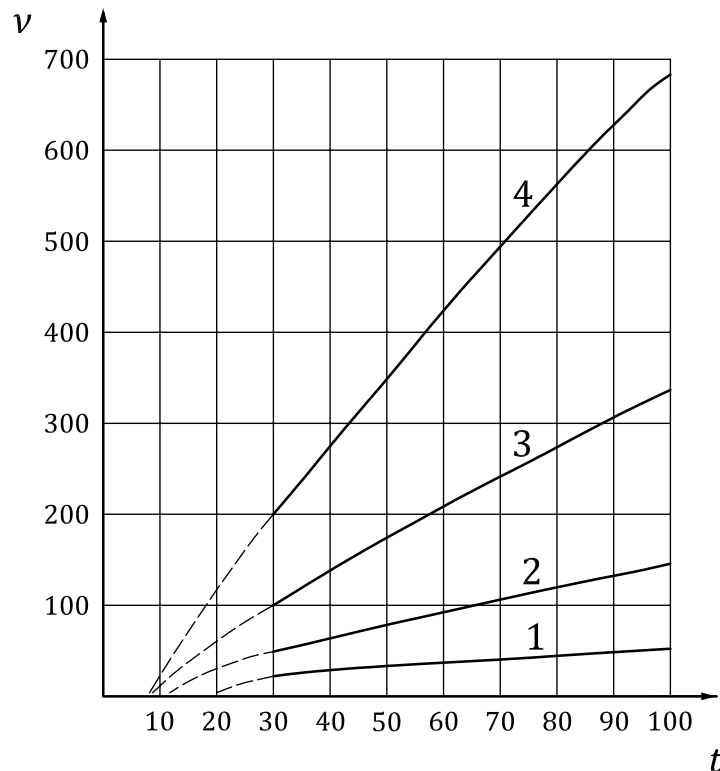
**Key**

- 1 3-mm flow cup
- 2 4-mm flow cup
- 3 5-mm flow cup
- 4 6-mm flow cup

t flow time, in seconds

ν kinematic viscosity, in square millimetres per second

iTeh STANDARD PREVIEW
(standards.iteh.ai)

[ISO 2431:2019](https://standards.iteh.ai/catalog/standards/sist/880a209e-fa6b-48e8-a005-a8a4ef060552/iso-2431-2019)

<https://standards.iteh.ai/catalog/standards/sist/880a209e-fa6b-48e8-a005-a8a4ef060552/iso-2431-2019>

Figure 2 — Conversion curves for 3-mm, 4-mm, 5-mm and 6-mm flow cups

5.1.6 Marking

Each flow cup shall have the following inscriptions permanently and legibly marked on it:

- a) designation of flow cup:
Flow cup ISO 2431, No 3, No 4, No 5 or No 6;
- b) manufacturer's identification number;
- c) manufacturer's name or trade mark.

5.1.7 Care and checking of flow cups

Clean the flow cup immediately after use and before the sample starts to dry, using a suitable solvent. Never use metal tools or a wire scourer for cleaning purposes. If the orifice becomes contaminated with dried deposits, soften these with a suitable solvent and clean carefully, for example with a soft cloth pulled through the orifice.

Check the flow cups periodically for wear and tear using one of the procedures specified in [Annex A](#).