Truck and bus tyres and rims (metric series) —

Part 2: Rims

Pneumatiques et jantes (séries millimétriques) pour camions et autobus —

Partie 2 — Jantes

ITeH STANDARD PREVIEW
(standards.iteh.ai)
Full standard:
<https://standards.iteh.ai/catalog/standards/sist/1e98670-0994-4e67-baa4-2635e2cdefb5/iso-4209-2-2020>



iTeh STANDARD PREVIEW
(standards.iteh.ai)
Full standard:
<https://standards.iteh.ai/catalog/standards/sist/1e980570-0994-4e67-baa4-2635e2cdefb5/iso-4209-2-2020>



COPYRIGHT PROTECTED DOCUMENT

© ISO 2020

All rights reserved. Unless otherwise specified, or required in the context of its implementation, no part of this publication may be reproduced or utilized otherwise in any form or by any means, electronic or mechanical, including photocopying, or posting on the internet or an intranet, without prior written permission. Permission can be requested from either ISO at the address below or ISO's member body in the country of the requester.

ISO copyright office
CP 401 • Ch. de Blandonnet 8
CH-1214 Vernier, Geneva
Phone: +41 22 749 01 11
Email: copyright@iso.org
Website: www.iso.org

Published in Switzerland

Contents

	Page
Foreword	iv
1 Scope	1
2 Normative references	1
3 Terms and definitions	1
4 Designation and marking	1
5 5° tapered (drop-centre) rims	1
5.1 Rim flange	1
5.2 Rim contours	1
5.3 Rim diameter and hump circumference	4
5.4 Valve holes	4
6 15° tapered (drop-centre) rims	5
6.1 Rim contours	5
6.2 Rim diameters	8
6.3 Valve holes	8
6.3.1 General	8
6.3.2 Characteristics of valve holes	9
Bibliography	11

iTeh STANDARD PREVIEW
 (standards.iteh.ai)
 Full standard:
<https://standards.iteh.ai/catalog/standards/sist/1e980370-0994-4e67-baa4-2635e2cdefb5/iso-4209-2-2020>

Foreword

ISO (the International Organization for Standardization) is a worldwide federation of national standards bodies (ISO member bodies). The work of preparing International Standards is normally carried out through ISO technical committees. Each member body interested in a subject for which a technical committee has been established has the right to be represented on that committee. International organizations, governmental and non-governmental, in liaison with ISO, also take part in the work. ISO collaborates closely with the International Electrotechnical Commission (IEC) on all matters of electrotechnical standardization.

The procedures used to develop this document and those intended for its further maintenance are described in the ISO/IEC Directives, Part 1. In particular, the different approval criteria needed for the different types of ISO documents should be noted. This document was drafted in accordance with the editorial rules of the ISO/IEC Directives, Part 2 (see www.iso.org/directives).

Attention is drawn to the possibility that some of the elements of this document may be the subject of patent rights. ISO shall not be held responsible for identifying any or all such patent rights. Details of any patent rights identified during the development of the document will be in the Introduction and/or on the ISO list of patent declarations received (see www.iso.org/patents).

Any trade name used in this document is information given for the convenience of users and does not constitute an endorsement.

For an explanation of the voluntary nature of standards, the meaning of ISO specific terms and expressions related to conformity assessment, as well as information about ISO's adherence to the World Trade Organization (WTO) principles in the Technical Barriers to Trade (TBT), see www.iso.org/iso/foreword.html.

This document was prepared by Technical Committee ISO/TC 31, *Tyres, rims and valves*, Subcommittee SC 4, *Truck and bus tyres and rims*.

This fifth edition cancels and replaces the fourth edition (ISO 4209-2:2012), which has been technically revised.

The main change compared to the previous edition is as follows: figures and 5.2, Note have been corrected.

A list of all parts in the ISO 4209 series can be found on the ISO website.

Any feedback or questions on this document should be directed to the user's national standards body. A complete listing of these bodies can be found at www.iso.org/members.html.

Truck and bus tyres and rims (metric series) —

Part 2: Rims

1 Scope

This document specifies the designations, contours and dimensions of drop-centre (one-piece) rims for use on trucks and buses.

The rim dimensions are those rim contour dimensions necessary for mounting and fitment of the tyre to the rim.

Tyre designations, dimensions and load ratings are given in ISO 4209-1.

2 Normative references

The following documents are referred to in the text in such a way that some or all of their content constitutes requirements of this document. For dated references, only the edition cited applies. For undated references, the latest edition of the referenced document (including any amendments) applies.

ISO 3911, *Wheels and rims for pneumatic tyres — Vocabulary, designation and marking*

ISO 4000-2, *Passenger car tyres and rims — Part 2: Rims*

3 Terms and definitions

For the purposes of this document, the terms and definitions given in ISO 3911 apply.

ISO and IEC maintain terminological databases for use in standardization at the following addresses:

- ISO Online browsing platform: available at <https://www.iso.org/obp>
- IEC Electropedia: available at <http://www.electropedia.org/>

4 Designation and marking

The rim shall be designated by its nominal rim diameter code and nominal rim width code (e.g. 17.5 × 5.25), and rim flange type when specified (for example: 16 × 6 K).

5 5° tapered (drop-centre) rims

5.1 Rim flange

Recommended rim flange contours for K rims are given in [Table 1](#).

Refer to ISO 4000-2 for B and J contour rims.

5.2 Rim contours

The dimensions and tolerances of the rims shall be as given in [Figure 1](#) and [Tables 1, 2, and 4](#).

Optional bead seat contours and their dimensions are given in Figure 2 and Table 3 and 4.

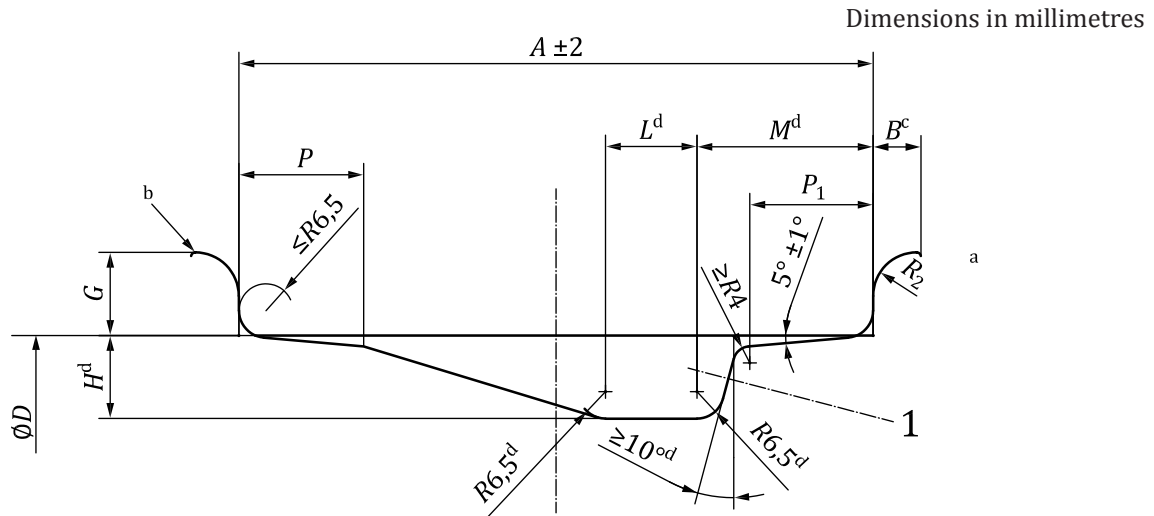

Key

- 1 valve hole (see 5.4)
- a Tyre-mounting side.
- b The break corner is equivalent to a radius R of minimum 0,5 mm.
- c Flange width includes edge radius. The portion of a flange beyond the minimum width shall not be higher than the highest point of the flange.
- d These dimensions comprise the minimum well envelope for tyre-mounting purposes, except for localized areas at the weld or the valve hole.

NOTE For use with tubeless tyres, humps are necessary on the outboard side and preferred on the inboard side.

Figure 1 — Contour of 5° tapered (drop-centre) rims

Table 1 — Dimensions of 5° tapered (drop-centre) rim contours

Dimensions in millimetres

Nominal rim diameter code	Nominal rim width code and flange type	B	G	P	P_1	H^a	L	M	R_2
		min.	±1,0	min.	min.	gauge	gauge	max.	min.
16	6 K and wider	11,5	20	19,5	19,5	20	22	47	10,5

^a Minimum dimensions for the well depth, H , and the well angle are required for tyre-mounting. Larger values can be required to ensure sufficient space for tubeless tyre valve seating.

Table 2 — Nominal rim width code

Nominal rim width code ^a	A mm
6	152,5
6 1/2	165
7	178
7 1/2	190,5
8	203

^a In case of exceeding the nominal rim width code 15, dimension “ A ” follows the next formula. $A = \text{nominal rim width code} \times 25,4$ (rounded to 0,5 mm) (increments of code = 0,5).

Table 2 (continued)

Nominal rim width code ^a	A mm
8 1/2	216
9	228,5
9 1/2	241,5
10	254
10 1/2	266,5
11	279,5
12	305
13	330
14	355,5
15	381

^a In case of exceeding the nominal rim width code 15, dimension "A" follows the next formula.
 $A = \text{nominal rim width code} \times 25,4$ (rounded to 0,5 mm) (increments of code = 0,5).

Dimensions in millimetres

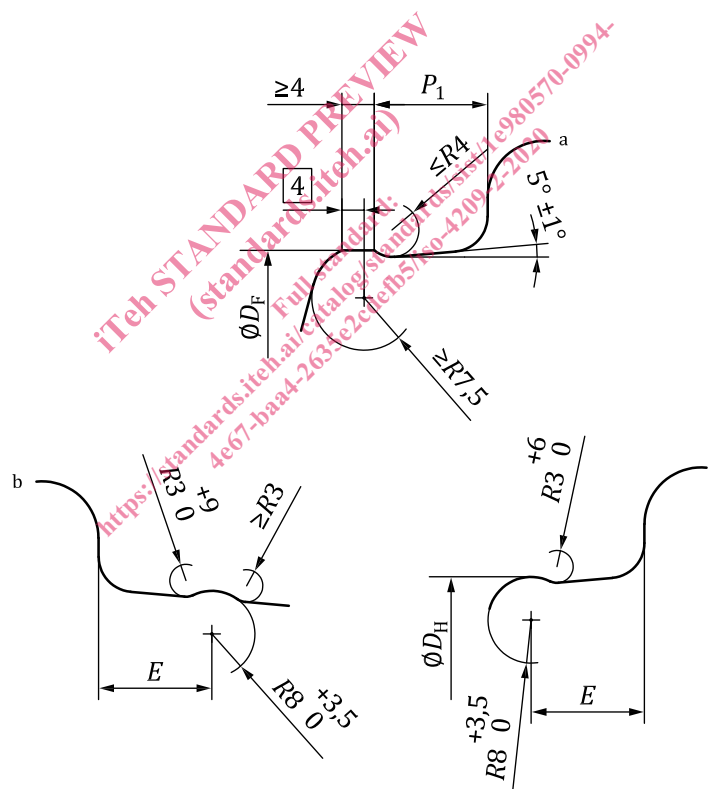

- a Tyre-mounting side.
- b Tyre non-mounting side.

Figure 2 — Optional bead seat contours

Table 3 — E dimension for round humps

Nominal rim width code and flange type	<i>E</i> mm
6 K and wider	21 ^{+2,0} ₀
For <i>E</i> , 19,5 ^{+2,0} ₀ is also permitted.	

5.3 Rim diameter and hump circumference

The specified rim diameter, *D*, for the appropriate nominal rim diameter code and the hump circumferences are given in [Table 4](#).

Table 4 — Specified rim diameter and hump circumference of 5° tapered (drop-centre) rims

Dimensions in millimetres

Nominal rim diameter code	Specified rim diameter ^a <i>D</i> ± 0,4	Hump circumference	
		Flat hump 0 -3,5	Round hump ^b 0 -3,0
16	405,6	1 274,2	1 276,4

^a The tolerance for the specified rim diameter is for tyre design purposes only. The rim measurement is by a circumference-measuring tape related to a mandrel.

^b For round humps on the vehicle inboard side only, a tolerance of $\pm 5,0$ is also permitted.

5.4 Valve holes

5.4.1 Valve hole edges on the tyre side of rim shall be rounded or chamfered.

5.4.2 Valve hole edges on the weather (external) side of the rim shall be free from any burrs that could damage the valve.

5.4.3 To provide for adequate sealing, an unbroken, smooth inside surface having at least 0,75 mm or 25 % of rim thickness, whichever is greater, shall be maintained.

5.4.4 Suitable valves shall be used. Valve hole details for snap-in valves shall be as shown in [Figures 3](#) and [4](#) for rims with 17,3 mm minimum well depth.

Dimensions in millimetres

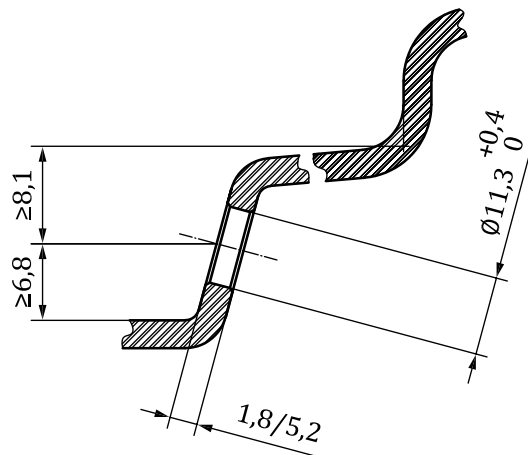
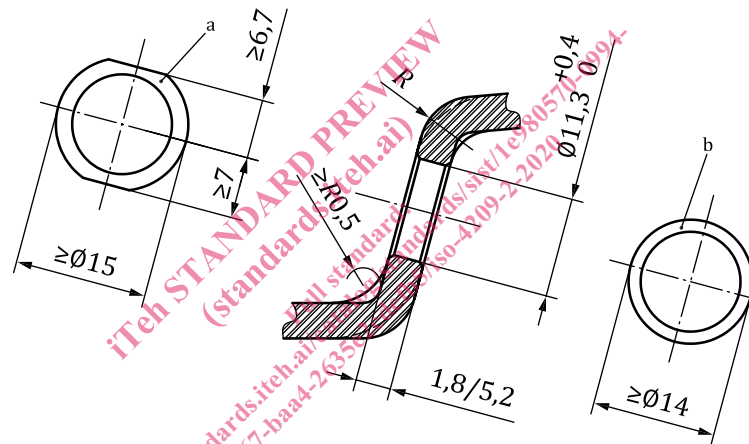

Figure 3 — Valve hole dimensions

Dimensions in millimetres



- a Flat surface with no radial striations.
- b Flat surface for clamp-in valves.

Figure 4 — Optional flat surface around valve hole

6 15° tapered (drop-centre) rims

6.1 Rim contours

The dimensions and tolerances of rims shall be as given in [Figure 5](#) and [Tables 5](#) and [6](#).