



Designation: ~~G90-05~~ Designation: G90 - 10

Standard Practice for Performing Accelerated Outdoor Weathering of Nonmetallic Materials Using Concentrated Natural Sunlight¹

This standard is issued under the fixed designation G90; the number immediately following the designation indicates the year of original adoption or, in the case of revision, the year of last revision. A number in parentheses indicates the year of last reappraisal. A superscript epsilon (ϵ) indicates an editorial change since the last revision or reappraisal.

1. Scope

1.1 Fresnel-reflecting concentrators using the sun as source are utilized in the accelerated outdoor exposure testing of nonmetallic materials.

1.2 This practice covers a procedure for performing accelerated outdoor exposure testing of nonmetallic materials using a Fresnel-reflector accelerated outdoor weathering test machine. The apparatus (see Fig. 1 and Fig. 2) and guidelines are described herein to minimize the variables encountered during outdoor accelerated exposure testing.

1.3 This practice does not specify the exposure conditions best suited for the materials to be tested but is limited to the method of obtaining, measuring, and controlling the procedures and certain conditions of the exposure. Sample preparation, test conditions, and evaluation of results are covered in existing methods or specifications for specific materials.

1.4 The Fresnel-reflector accelerated outdoor exposure test machines described may be suitable for the determination of the relative durability of materials exposed to sunlight, heat, and moisture, provided the mechanisms of chemical or physical change, or both, which control the rates of acceleration factors for the materials do not differ significantly.

1.5 This practice establishes uniform sample mounting and in-test maintenance procedures. Also included in the practice are standard provisions for maintenance of the machine and Fresnel-reflector mirrors to ensure cleanliness and durability.

1.6 This practice shall apply to specimens whose size meets the dimensions of the target board as described in 8.2.

1.7 For test machines currently in use, this practice may not apply to specimens exceeding 13 mm ($\frac{1}{2}$ in.) in thickness because cooling may be questionable.

1.8 Values stated in SI units are to be regarded as the standard. The inch-pound units in parentheses are provided for information only.

1.9 *This standard does not purport to address all of the safety concerns, if any, associated with its use. It is the responsibility of the user of this standard to establish appropriate safety and health practices and determine the applicability of regulatory limitations prior to use.*

2. Referenced Documents

2.1 *ASTM Standards:*²

D859 Test Method for Silica in Water

D1014 Practice for Conducting Exterior Exposure Tests of Paints and Coatings on Metal Substrates

D1435 Practice for Outdoor Weathering of Plastics

D1898 Practice for Sampling of Plastics³

D4141 Practice for Conducting Black Box and Solar Concentrating Exposures of Coatings

D4517 Test Method for Low-Level Total Silica in High-Purity Water by Flameless Atomic Absorption Spectroscopy

E816 Test Method for Calibration of Pyrheliometers by Comparison to Reference Pyrheliometers

E824 Test Method for Transfer of Calibration From Reference to Field Radiometers E891 Tables for Terrestrial Direct Normal Solar Spectral Irradiance for Air Mass 1.5⁶

E903 Test Method for Solar Absorptance, Reflectance, and Transmittance of Materials Using Integrating Spheres

G7 Practice for Atmospheric Environmental Exposure Testing of Nonmetallic Materials

¹ This practice is under the jurisdiction of ASTM Committee G03 on Weathering and Durability and is the direct responsibility of Subcommittee G03.02 on Natural and Environmental Exposure Tests.

Current edition approved October 1, 2005; 2010. Published November 2005; June 2010. Originally approved in 1985. Last previous edition approved in 1998; 2005 as G90-98; G90-05. DOI: 10.1520/G0090-105.

² For referenced ASTM standards, visit the ASTM website, www.astm.org, or contact ASTM Customer Service at service@astm.org. For Annual Book of ASTM Standards volume information, refer to the standard's Document Summary page on the ASTM website.

³ Withdrawn. The last approved version of this historical standard is referenced on www.astm.org.

- | | |
|--------------------------|-----------------------------|
| A - AIR PLENUM | H - MAST, AZIMUTH ADJUST |
| B - AIR BLOWER | I - AIR FLOW SWITCH |
| C - ROTOR ASSEMBLY | J - WATER SPRAY NOZZLE |
| D - AIR DEFLECTOR | K - CLUTCH DISC, ELEV DRIVE |
| E - A-FRAME ASSEMBLY | L - SOLAR CELLS/SHADOW HAT |
| F - MIRROR | M - SAMPLE PROTECTION DOOR |
| G - GEAR BOX, ELEV DRIVE | N - DOOR RELEASE MECHANISM |

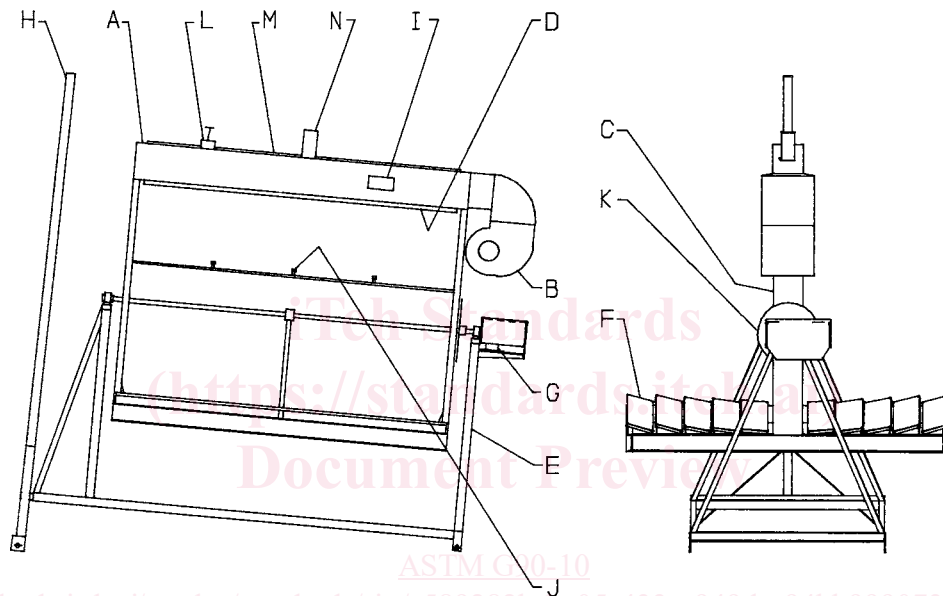

FIG. 1 Schematic of Fresnel-Reflecting Concentrator Accelerated Weathering Machine Single Axis Tracking

- G24 [Practice for Conducting Exposures to Daylight Filtered Through Glass](#)
- G113 [Terminology Relating to Natural and Artificial Weathering Tests of Nonmetallic Materials](#)
- G167 [Test Method for Calibration of a Pyranometer Using a Pyrheliometer](#)
- G169 [Guide for Application of Basic Statistical Methods to Weathering Tests](#) Guide for Application of Basic Statistical Methods to Weathering Tests
- G173 [Tables for Reference Solar Spectral Irradiances: Direct Normal and Hemispherical on 37 Tilted Surface](#)

- | | |
|--------------------------|-----------------------------|
| A - AIR PLENUM | I - GEAR BOX, AZIMUTH DRIVE |
| B - AIR BLOWER | J - AIR FLOW SWITCH |
| C - ROTOR ASSEMBLY | K - WATER SPRAY NOZZLE |
| D - TURN TABLE ASSEMBLY | L - CLUTCH DISC, ELEV DRIVE |
| E - A-FRAME ASSEMBLY | M - SOLAR CELLS/SHADOW HAT |
| F - MIRROR | N - SAMPLE PROTECTION DOOR |
| G - GEAR BOX, ELEV DRIVE | O - DOOR RELEASE MECHANISM |
| H - CONTROL BOX | P - AIR DEFLECTOR |

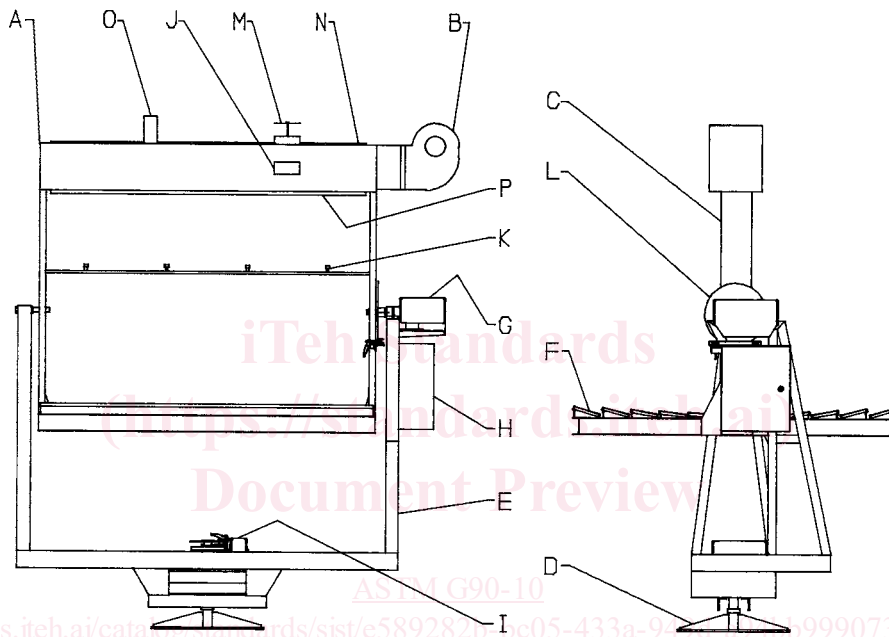

FIG. 2 Dual Axis Tracking

2.2 Other Standards:

SAE J576 Plastic Materials for Use in Optical Parts Such as Lenses and Reflectors of Motor Vehicle Lighting Devices⁴
 WMO Guide to Meteorological Instruments and Methods of Observation WMO No. 8, Fifth Edition⁵

3. Terminology

3.1 *Definitions*—Definitions of terms common to G₀₃ durability standards can be found in Terminology G113.

4. Significance and Use

4.1 Results obtained from this practice can be used to compare the relative durability of materials subjected to the specific test cycle used. No accelerated exposure test can be specified as a total simulation of natural or field exposures. Results obtained from this practice can be considered as representative of natural or field exposures only when the degree of comparative performance has been established for the specific materials being tested.

4.2 The relative durability of materials in natural or field exposure can be very different depending on the location of the exposure because of differences in UV radiation, time of wetness, temperature, pollutants, and other factors. Therefore, even if results from a specific accelerated test condition are found to be useful for comparing the relative durability of materials exposed in a particular exterior location, it cannot be assumed that they will be useful for determining relative durability for a different location.

⁴ Available from SAE International (SAE), 400 Commonwealth Dr., Warrendale, PA 15096-0001, <http://www.sae.org>.

⁵ Available from World Meteorological Organization, (WMO), 7bis, avenue de la Paix, Case postale 2300, CH-1211 Geneva 2, Switzerland, <http://www.wmo.int>.

⁶ Available from World Meteorological Organization, Geneva, Switzerland.

4.3 The use of a single acceleration factor relating the rate of degradation in this accelerated exposure to the rate of degradation in a conventional exterior exposure is not recommended because the acceleration factor varies with the type and formulation of the material. Each material and formulation may respond differently to the increased level of irradiance and differences in temperature and humidity. Thus an acceleration factor determined for one material may not be applicable to other materials. Because of variability in test results under both accelerated and conventional exterior exposures results from a sufficient number of tests must be obtained to determine an acceleration factor for a material. Further, the acceleration factor is applicable to only one exterior exposure location because results from conventional exterior exposures can vary due to seasonal or annual differences in important climatic factors.

4.4 Variations in results may be expected when operating conditions vary within the limits of this practice. For example, there can be large differences in the amount of degradation in a single material between separate, although supposedly identical, exposures carried out for the same duration or number of exposure cycles. This practice is best used to compare the relative performance of materials tested at the same time in the same fresnel reflector device. Because of possible variability between the same type of exposure device and variability in irradiance, temperature and moisture levels at different times, comparing the amount of degradation in materials exposed for the same duration or radiant energy at separate times is not recommended.

4.5 This practice should not be used to establish a “pass/fail” approval of materials after a specific period of exposure unless performance comparisons are made relative to a control material exposed simultaneously, or the variability in the test is defined so that statistically significant pass/fail judgements can be made. It is strongly recommended that at least one control test specimen be exposed with each test. The control test specimen should meet the requirements of Terminology G113, and be chosen so that its failure mode is the same as that of the test specimen. It is preferable to use two control test specimens, one with relatively good durability and one with relatively poor durability.

4.6 The use of at least two replicates of each control test specimen and each material being evaluated is recommended. Consult Guide G169 for performing statistical analysis.

5. Apparatus

5.1 *Test Machines*—Fresnel-reflector test machines used in Cycles 1, 2, and 3 of Table 1 are nearly identical. The only difference between the machines is the addition of a water delivery system to the device used in Cycles 1 and 3. Use of the specific cycle should relate to end use of the material and should be agreed upon by all interested parties.

5.1.1 The Fresnel-reflector test machine is a follow-the-sun apparatus having flat mirrors so positioned that the sun’s rays strike them at near-normal incident angles while in operation. The mirrors are arranged to simulate tangents to a parabolic trough in order to reflect sunlight uniformly onto the specimens in the target area (see Fig. 1, Fig. 2, and Fig. 3).

5.1.2 The test machine is equipped with a blower to cool the test specimens. The air is directed over the specimens by an adjustable deflector along one side of the target area. For unbacked mounting, air is also directed under the specimens. This limits the increase in surface temperatures of most specimens to 10°C above the maximum surface temperature that would be reached when identically mounted specimens are exposed to direct sunlight at normal incidence at the same time and location without concentration.

5.2 *Mirrors*—The Fresnel-reflector system mirrors of machines currently in use have a typical specular, spectral reflectance curve such as that presented in Fig. 4. Other mirrors may be used providing they meet the requirements of 6.2.

5.3 *Photoreceptor Cells*—Two photoreceptor cells, such as silicon solar cells, are installed near the top of the air tunnel on the side facing the sun. A “T” shadow maker is mounted above the cells to illuminate equally one-half of each cell when the test machine is in proper focus. As one cell receives more radiation than the other, the balance is disturbed and a signal is furnished through an amplifier to a reversible motor which adjusts the machine to maintain focus.

5.4 *Tracking System*—The test machine shall be equipped with a system to keep the target area in focus throughout the day. Several options are possible.

5.4.1 Single-axis tracking with manual altitude adjustment (Fig. 1). The test machine’s axis is oriented in the north/south direction, with the north pole being altitude-adjustable to account for seasonable variations in solar altitude at zenith.

5.4.2 Dual axis tracking (Fig. 2). The test machine is equipped with two sets of photoreceptor cells, one to control the azimuth rotation of the machine, the other to control the tilt elevation. The axis of the target area remains parallel to the ground. The

TABLE 1 Fresnel-Reflector Test Machine Typical Spray Cycles

Cycle	Daytime			Nighttime		
	Spray Duration	Dry-Time Duration	Cycles/h	Spray Duration	Dry-Time Duration	Cycles/h
1	8 min	52 min	1	8 min		water is sprayed on the test specimens at: 9:00 p.m. 12:00 midnight 3:00 a.m.
2	no water spray used			no water spray used		
3 ^A	no water spray used			3 min	12 min	4 cycles per hour (from 7PM to 5 AM)

^A This is the cycle specified in Procedure C of Practice D4141.

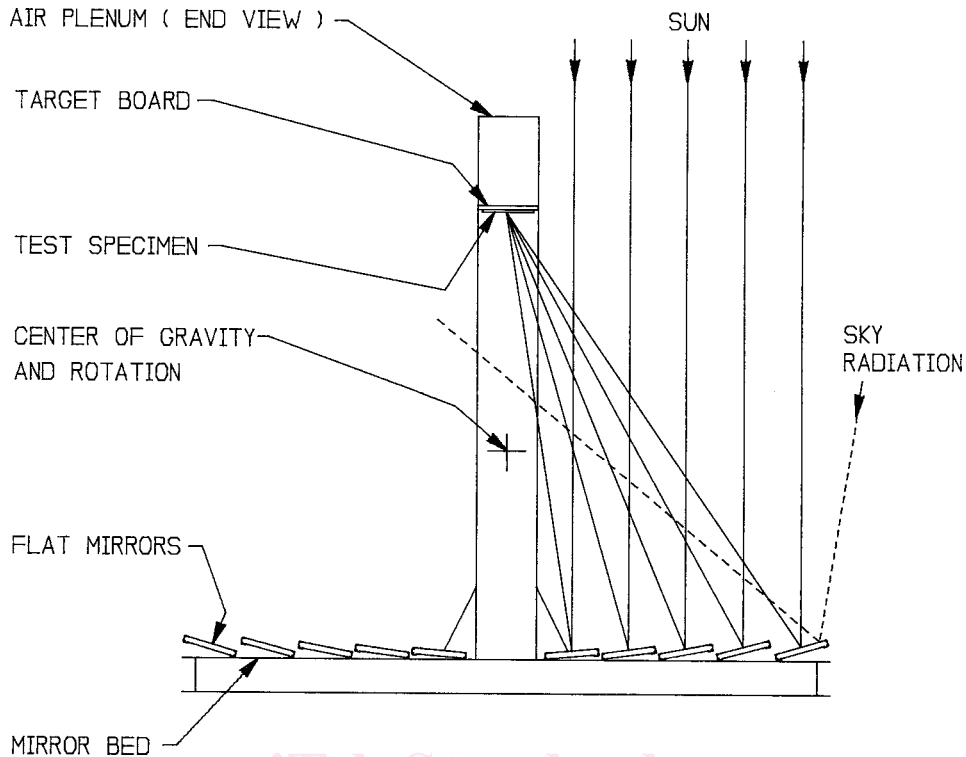

FIG. 3 Schematic of Optical System for a Fresnel Reflecting Concentrator Accelerated Weathering Machine

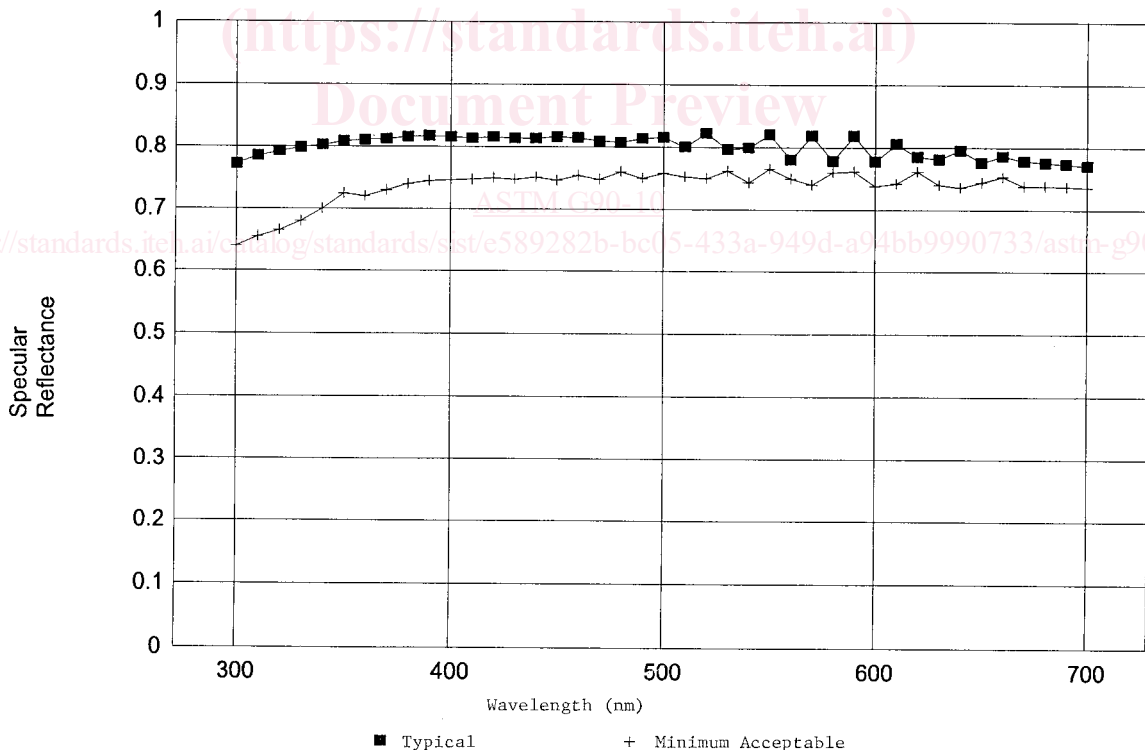

FIG. 4 Typical Specular Reflectance of Mirror Material

machine rotates about horizontal and vertical axes to keep the target area in focus.

5.5 *Nozzles*—The test machine used in Cycles 1 and 3 of Table 1 is provided with a nozzle assembly for spraying water onto the specimens during exposure. Fan spray nozzles which provide a uniform fine mist over the specimen area are recommended.

5.6 *Spray Orientation*—The apparatus shall be positioned so that specimens are sprayed at night either with specimens facing up or down.

5.6.1 *Specimens Face Down*—The apparatus is oriented with the mirrors below the target specimen area such that nozzles spray high purity water in an upward direction onto the specimens.

5.6.2 *Specimens Face Up*—The apparatus is oriented with the mirrors above the target specimen area such that nozzles spray high purity water in a downward direction onto the specimens.

NOTE 1—No data has been presented indicating that exposures performed using different spray orientations provide equivalent results, and as such, may provide different test results.

5.7 *Ultraviolet Radiometers*—Instrumental means of measuring 295 to 385 nm ultraviolet radiant exposure shall consist of two wavelength-band specific global irradiance radiometers, each connected to an integrating device to indicate the energy received in the specified wavelength band over a given period. The spectral response of the ultraviolet radiometers shall be known and shall be as flat as possible throughout the 295 to 385 nm spectral region utilized. Calibrations shall be performed using sunlight as the source. The pyranometer shall be calibrated in accordance with Method E824 no less often than annually. A black-painted permanent shading disk is positioned over one radiometer as shown in Fig. 6 and Figs. 7-9 to provide a diffuse-only measurement (excluding 6° field of view).

5.8 *Pyranometer*—Instrumental means of measuring full-spectrum solar radiant exposure shall consist of a pyranometer connected to an integrating device to indicate the total energy received over a given period. The pyranometer shall be a World Meteorological Organization (WMO) Second Class instrument or better as defined by the WMO Guide to Meteorological Instruments. The pyranometer shall be calibrated in accordance with Test Method E824 or G167 at least annually.

5.9 *Pyrheliometer*—Instrumental means of measuring full-spectrum solar radiant exposure in a 5 to 6.5 degree field of view shall consist of a pyrliometer connected to an integrating device to indicate the total energy received over a given period. The pyrliometer shall be a World Meteorological Organization (WMO) First Class instrument or better as defined by the WMO Guide to Meteorological Instruments. The pyrliometer shall be calibrated in accordance with Test Method E816 at least annually

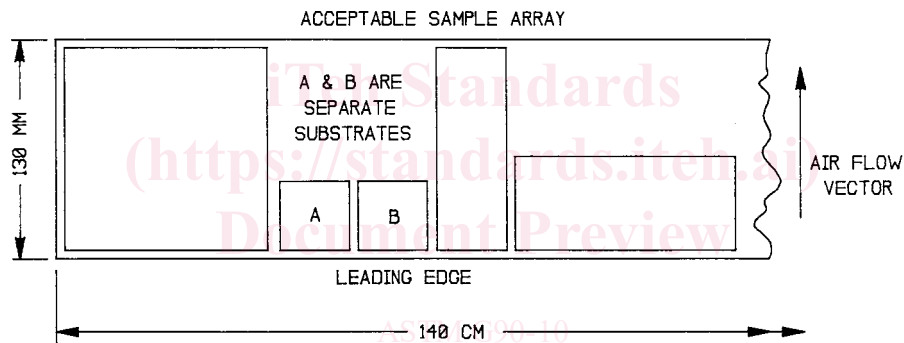

<https://standards.iteh.ai/catalog/standards/sist/e589282b-bc05-433a-949d-a94bb9990733/astm-g90-10>

- CORRECT MOUNTING -
Each specimen is mounted with one edge against leading edge of target area for maximum cooling

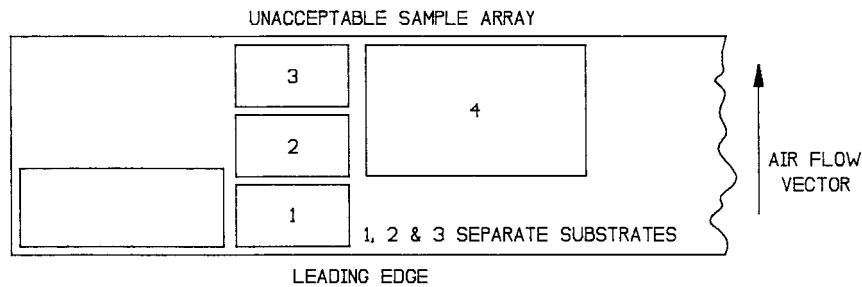

- INCORRECT MOUNTING -

- 1) Specimens 1, 2, and 3 are mounted one behind the other. Mounting frames and gaps between specimens will likely disturb the air flow, preventing adequate cooling.
- 2) Specimen 4 is not against the leading edge and is not receiving maximum cooling.

FIG. 5 Examples of Correctly and Incorrectly Mounted Specimens