



Designation: D4935 – 10

Standard Test Method for Measuring the Electromagnetic Shielding Effectiveness of Planar Materials¹

This standard is issued under the fixed designation D4935; the number immediately following the designation indicates the year of original adoption or, in the case of revision, the year of last revision. A number in parentheses indicates the year of last reapproval. A superscript epsilon (ϵ) indicates an editorial change since the last revision or reapproval.

1. Scope

1.1 This test method provides a procedure for measuring the electromagnetic (EM) shielding effectiveness (SE) of a planar material for a plane, far-field EM wave. From the measured data, near-field SE values may be calculated for magnetic (H) sources for electrically thin specimens.^{2,3} Electric (E) field SE values may also be calculated from this same far-field data, but their validity and applicability have not been established.

1.2 The measurement method is valid over a frequency range of 30 MHz to 1.5 GHz. These limits are not exact, but are based on decreasing displacement current as a result of decreased capacitive coupling at lower frequencies and on overmoding (excitation of modes other than the transverse electromagnetic mode (TEM)) at higher frequencies for the size of specimen holder described in this test method. Any number of discrete frequencies may be selected within this range. For electrically thin, isotropic materials with frequency independent electrical properties of conductivity, permittivity, and permeability, measurements may be needed at only a few frequencies as the far-field SE values will be independent of frequency. If the material is not electrically thin or if any of the parameters vary with frequency, measurements should be made at many frequencies within the band of interest.

1.3 This test method is not applicable to cables or connectors.

1.4 *Units*—The values stated in SI units are to be regarded as standard. No other units of measurement are included in this standard.

1.5 *This standard does not purport to address all of the safety concerns, if any, associated with its use. It is the responsibility of the user of this standard to establish appro-*

priate safety and health practices and determine the applicability of regulatory limitations prior to use.

2. Referenced Documents

2.1 *ASTM Standards*:⁴

[D1711 Terminology Relating to Electrical Insulation](#)

3. Terminology

3.1 *Definitions*—For definitions of terms used in this test method, refer to Terminology [D1711](#).

3.2 *Definitions of Terms Specific to This Standard*:

3.2.1 *dynamic range (DR), n*—difference between the maximum and minimum signals measurable by the system.

3.2.1.1 *Discussion*—Measurement of materials with good SE require extra care to avoid contamination of extremely low power or voltage values by unwanted signals from leakage paths.

3.2.2 *electrically thin, adj*—thickness of the specimen is much smaller ($<1/100$) than the electrical wavelength within the specimen.

3.2.3 *far field, n*—that region where vectors E and H are orthogonal to each other and both are normal to the direction of propagation of energy.

3.2.4 *near field, n*—that region where E and H are not related by simple rules.

3.2.4.1 *Discussion*—The transition region between near field and far field is not abrupt but is located at the distance close to $\lambda/2\pi$ from a dipole source, where λ is the free-space wave length of the frequency of the source. This concept of regions is further blurred by reradiating as a result of scattering by reflecting materials or objects that may be distant from the source. The interior of metallic structures often contains a mixture of near-field regions.

3.2.5 *shielding effectiveness (SE), n*—ratio of power received with and without a material present for the same incident power.

¹ This test method is under the jurisdiction of ASTM Committee D09 on Electrical and Electronic Insulating Materials and is the direct responsibility of Subcommittee D09.12 on Electrical Tests.

Current edition approved May 1, 2010. Published June 2010. Originally approved in 1989. Last previous edition approved in 1999 as D 4935–99. DOI: 10.1520/D4935–10.

² Wilson, P. F., and Ma, M. T., “A Study of Techniques for Measuring the Electromagnetic Shielding Effectiveness of Materials,” NBS Technical Note 1095, May 1986.

³ Adams, J. W., and Vanzura, E. J., “Shielding Effectiveness Measurements of Plastics,” NBSIR 85-3035, January 1986.

⁴ For referenced ASTM standards, visit the ASTM website, www.astm.org, or contact ASTM Customer Service at service@astm.org. For *Annual Book of ASTM Standards* volume information, refer to the standard’s Document Summary page on the ASTM website.

3.2.5.1 *Discussion*—*SE* is usually expressed in decibels (dB) by the following equation:

$$SE = 10 \log \frac{P_1}{P_2} \text{ (dB)} \quad (1)$$

where:

P_1 = received power with the material present, and
 P_2 = received power without the material present.

If the receiver readout is in units of voltage, use the following equation:

$$SE = 20 \log \frac{V_1}{V_2} \text{ (dB)} \quad (2)$$

where:

V_1 and V_2 = respective voltage levels with and without a material present.

According to these equations, *SE* will have a negative value if less power is received with the material present than when it is absent.

4. Significance and Use

4.1 This test method applies to the measurement of *SE* of planar materials under normal incidence, far-field, plane-wave conditions (E and H tangential to the surface of the material).

4.2 The uncertainty of the measured *SE* values is a function of material, mismatches throughout the transmission line path, dynamic range of the measurement system, and the accuracy of the ancillary equipment. An uncertainty analysis is given in [Appendix X1](#) to illustrate the uncertainty that may be achieved by an experienced operator using good equipment. Deviations from the procedure in this test method will increase this uncertainty.

4.3 Approximate near-field values of *SE* may be calculated for both E or H sources by using measured values of far-field *SE*. A program may be generated from the source code in [Appendix X2](#) that is suitable for use on a personal computer.

4.4 This test method measures the net *SE* caused by reflection and absorption. Separate measurement of reflected and absorbed power may be accomplished by the addition of a calibrated bidirectional coupler to the input of the holder.

5. Apparatus

5.1 A basic equipment setup is shown in [Fig. 1](#).

5.2 *Specimen Holder*—Physical dimensions of a specimen holder are given in [Annex A1](#). The specimen holder is an enlarged, coaxial transmission line with special taper sections and notched matching grooves to maintain a characteristic impedance of 50 Ω throughout the entire length of the holder. This impedance is checked in accordance with [7.1](#), and any variations greater than ±0.5 Ω are corrected. There are three important aspects to this design. First, a pair of flanges in the

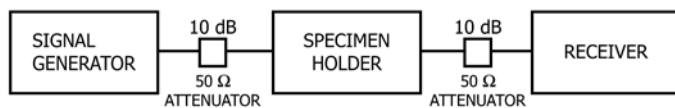

FIG. 1 General Test Setup

middle of the structure hold the specimen. This allows capacitive coupling of energy into insulating materials through displacement current. Second, a reference specimen of the same thickness and electrical properties as the load specimen causes the same discontinuity in the transmission line as is caused by the load specimen. Third, nonconductive (nylon) screws are used to connect the two sections of the holder together during tests. This prevents conduction currents from dominating the desired displacement currents necessary for the correct operation of this specimen holder.

5.3 *Signal Generator*, a source capable of generating a sinusoidal signal over the desired portion of the frequency range specified in [1.2](#). A 50-Ω output impedance is needed to minimize reflections caused by mismatches. Precision step attenuators are useful in increasing the effective dynamic range for *SE* measurements.

5.4 *Receiver*, a device with a 50-Ω input impedance capable of measuring signals over the same frequency range as the signal generator in [5.3](#). A wide dynamic range is desirable to achieve a wide dynamic range of measured *SE* values. Typically, either a spectrum analyzer or a field intensity meter is used.

5.5 *Coaxial Cables and Connectors*—These are devices for connecting power between specific components without causing interference with other components. These should all have a 50-Ω characteristic impedance. Double-shielded cables provide lower leakage than single-shielded cables. Type N connectors provide more reliability and less leakage than BNC connectors. Precision 14-mm connectors give lower mismatch errors and are more reliable under heavy usage than other connectors but are more expensive and are not used on most generators or receivers.

5.6 *Attenuators*—These are devices used to isolate the specimen holder from the signal generator and the receiver. Their main purpose in this system is for impedance matching. A 10-dB, 50-Ω attenuator should be used on each end of the specimen holder. The material under test usually causes a large reflection of energy back into the signal generator. This may also cause variations of the incident power by changing the generator impedance loading. Use of a bidirectional coupler allows monitoring and correcting any changes in incident power as a result of this loading. Attenuators greater than 10 dB will excessively decrease the dynamic range of the measurement system.

6. Test Specimens

6.1 The reference and load specimens shall be of the same material and thickness. Both are shown in [Fig. 2](#). Dimensions are shown in [Fig. 3](#). The load specimen can be larger than the outer diameter of the flange on the holder but keeping them to the dimensions shown in [Fig. 3](#) will expedite handling.

6.2 Specimen thickness is a critical dimension. For the best repeatability of *SE* measurements, reference specimen and load specimen shall be identical in thickness. For this test method, two specimens are considered to have identical thickness if the

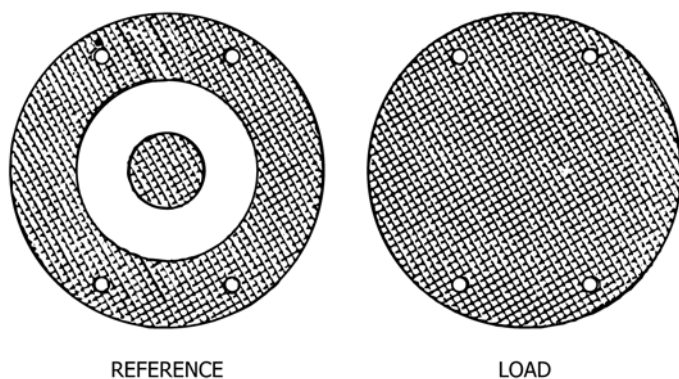

FIG. 2 Illustration of Reference and Load Specimens

difference in the average thicknesses is less than 25 μm and the thickness variation within and between specimens is less than 5 % of the average.

6.3 Materials of the specimens may be either homogeneous or inhomogeneous, single or multiple layered, and conducting or insulating. Measured SE values of inhomogeneous materials are dependent on geometry and orientation, and results are less repeatable than for homogeneous materials.

6.4 Before tests, condition test specimens for 48 h at $23 \pm 2^\circ\text{C}$ and $50 \pm 5\%$ relative humidity. Tests shall be performed immediately upon removal from the conditioning environment.

7. Preparation of Apparatus

7.1 An initial check of the specimen holder should be performed with a time-domain reflectometer or other suitable instrument to ensure that a characteristic impedance of $50 \pm 0.5 \Omega$ has been achieved during construction and that this impedance has not been degraded during shipment or handling. A time-domain system can give location of a mismatch in addition to its magnitude.

7.2 Each time the ancillary equipment is connected to the specimen holder, good practice requires measurement of a reference specimen to ensure the measurement system is in proper working order.

7.2.1 The dynamic range (DR) of the system can be checked by comparing the maximum signal level obtained with a reference specimen to the minimum signal level obtained when using a metallic load specimen. The lower limit of the measurement system sensitivity is a function of the sensitivity and bandwidth of the receiver. Narrowing the bandwidth of the receiver lowers the detectable level but increases the measurement time. Leakage caused by connectors or cables may reduce the DR of the system by providing a parallel signal path that does not pass through the specimen. If a step attenuator placed in series with the specimen holder causes a change in the minimum signal detected that corresponds to a change in attenuator setting, and if the step attenuator itself does not cause a leakage path, leakage is negligible and the DR measured above is correct. If the levels do not correspond, the attenuation should be increased until a one-to-one correspondence is achieved to determine the DR. Since leakage from a coaxial connector is determined not only by the quality of the

connector, but also by the amount of torque used in tightening the connector, connections should be rechecked.

7.2.2 If a standard reference specimen such as gold film deposited on mylar is available, measurement of its SE value can provide assurance that the entire system is working properly. A specimen with the surface resistivity of 5Ω commonly possess $\text{SE} = -32 \pm 3 \text{ dB}$. Any other known specimen may be used to check setup-to-setup repeatability.

7.2.3 Careful handling of the specimen holder and specimens is important.

7.3 Preparation of 7.2 should be run in accordance with procedures of Section 8.

8. Procedure

8.1 Follow the preparation of apparatus in accordance with 7.2 whenever the measurement system has been reconfigured or not used for several days.

8.2 Prepare two specimens in accordance with Section 6.

8.3 Determine all frequencies for which SE values are to be measured. The specimen mounting procedure described in 8.4 requires more time and effort than changing frequency, so it is more efficient to record values at all frequencies for the reference specimen, change to the load specimen, and then record load values at these same frequencies. This procedure can be automated if a computer and ancillary equipment with IEEE-488 bus capability are available.

8.4 The procedure for inserting the specimens is as follows: Use a support structure (a large roll of tape or special stand) to support the specimen holder in a vertical position. Remove two nylon screws, turn the holder end for end, remove the other two nylon screws, and carefully lift off the upper half of the holder. An indented, soft foam pad is useful for holding this upper half of the specimen holder while continuing the installation or removal of specimens. Place the two pieces of the reference specimen on the flange of the bottom half of the specimen holder ensuring that the disk for the center conductor is aligned correctly. Use small amounts of transparent tape as needed. Replace the half of the specimen holder that had been removed so that the holes for the nylon screws are aligned. Reinstall two nylon screws. Turn the holder end for end and then reinstall the other two nylon screws. Reconnect the coaxial cables.

8.5 Measure the received power (or voltage) while using the reference specimen. Record the measured received values as P_2 or V_2 values at each frequency.

8.6 Replace the reference specimen with the load specimen.

8.7 Measure the received power with the load specimen. Record these measured values as P_1 or V_1 values at the same frequencies used in 8.5. If this value is within 10 dB of the smallest detectable signal of the measurement system, either the receiver bandwidth shall be decreased and the measurement repeated, or the SE value is beyond the dynamic range of the measurement system and hence the SE value is reported as exceeding the DR of the system.

8.8 If the recorded units were watts, use the power ratio Eq 1 to calculate SE. If the recorded units were volts, use the voltage ratio Eq 2 from 3.2.5 to calculate the SE.

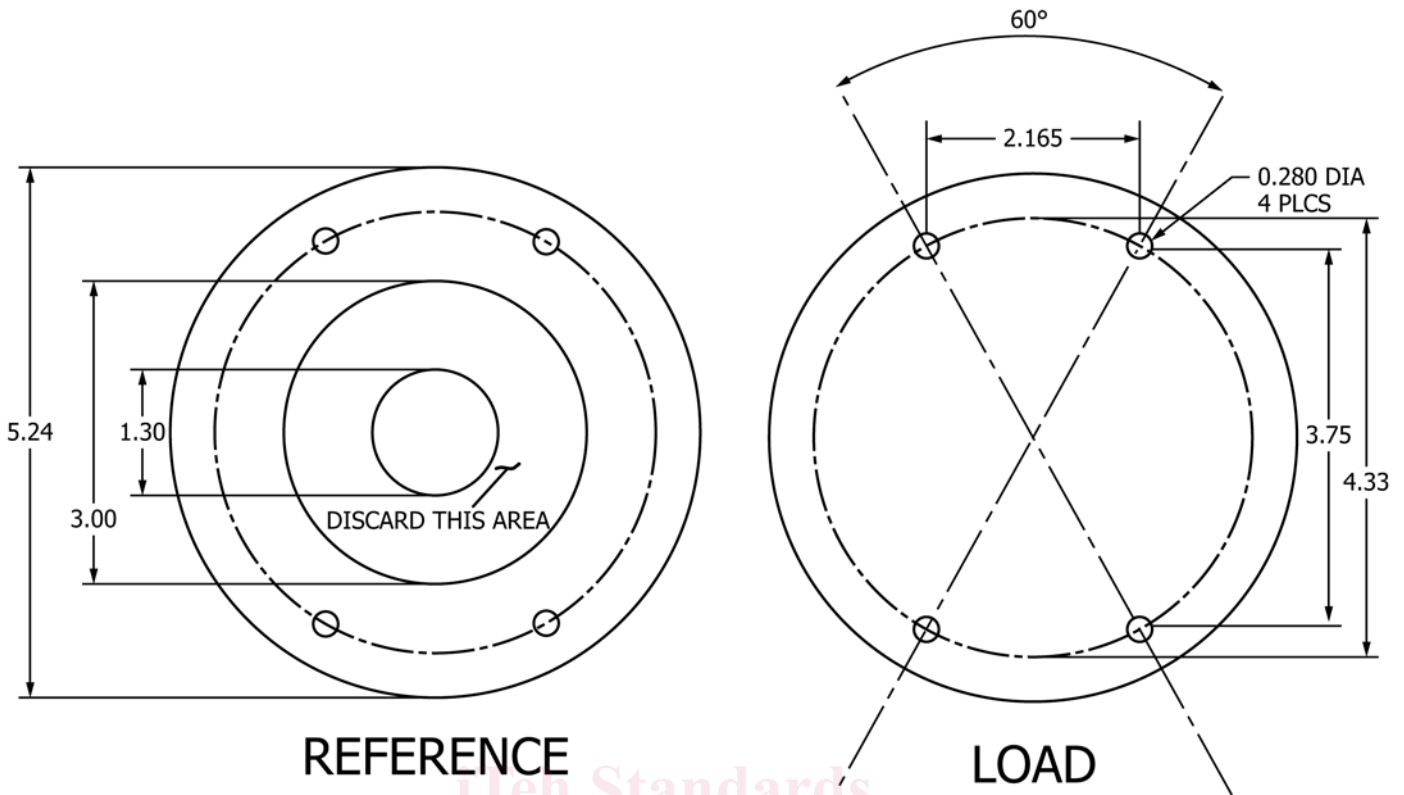

FIG. 3 Drawing That Gives Dimensions of Reference and Load Specimens

9. Report

9.1 The report should give test specimen identification and measured values of SE at each frequency of measurement.

9.2 Values of SE based on measured values from 8.7 that were within 10 dB of the smallest detectable signal of the measurement system should be noted as exceeding the DR of the measurement system.

10. Precision and Bias

10.1 Precision and bias are inherently affected by the choice of apparatus and specimens. For analysis and details, see Appendix X1.

11. Keywords

11.1 electromagnetic shielding; far field; near field; shielding; shielding effectiveness (SE)

ANNEX

(Mandatory Information)

A1. SET OF FIGURES SUITABLE FOR USE IN THE CONSTRUCTION OF A SPECIMEN HOLDER

A1.1 This annex contains a set of figures suitable for use in the construction of a specimen holder that has been shown to produce reliable measurements. They were contributed by the National Institute of Standards and Technology. Corrections to these figures were contributed by W. E. Measurements.⁵

A1.2 These figures are for one half of two identical halves of the specimen holder.

A1.2.1 Additional parts required are Type N male connectors (two required) and ¼ by 20 by 1 nylon screws (four required). The Type N connector is Midwest Microwave number 2679M.⁶

⁵The sole source of supply of the complete specimen holder known to the committee at this time is W. E. Measurements, P.O. Box 18056, Boulder, CO 80308. If you are aware of alternative suppliers, please provide this information to ASTM International Headquarters. Your comments will receive careful consideration at a meeting of the responsible technical committee,¹ which you may attend.

⁶The sole source of supply of the apparatus known to the committee at this time is Midwest Microwave Inc., 3800 Packard Road, Ann Arbor, MI 48104. If you are aware of alternative suppliers, please provide this information to ASTM International Headquarters. Your comments will receive careful consideration at a meeting of the responsible technical committee,¹ which you may attend.

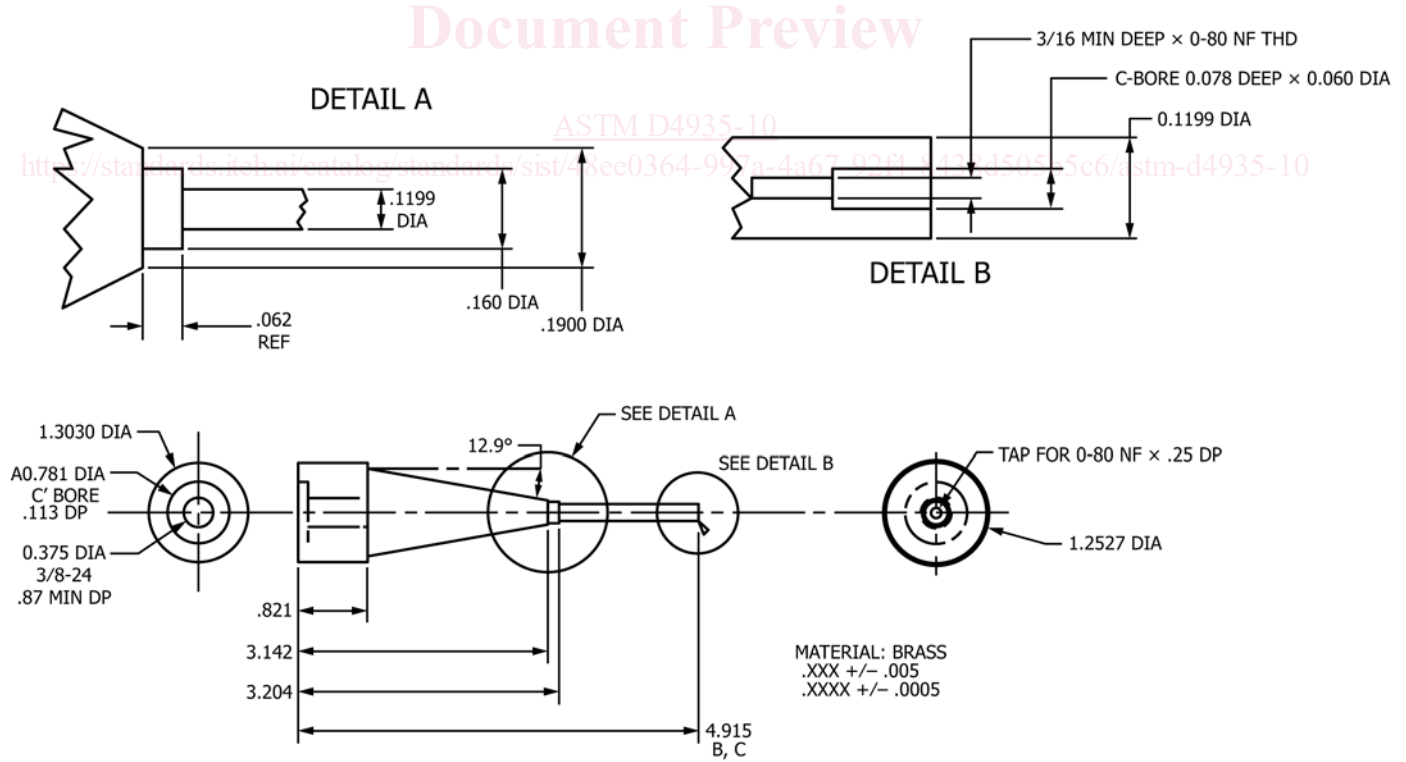

- NOTES:
 A. PRESS FIT WITH PART C.
 B. MAKE +.050 ASSEMBLE AND ADJUST
 C. TO BE ASSEMBLED AND LENGTH CUT TO SAME LENGTH AS PART G, .3743 Ø LENGTH

PART A

FIG. A1.1 Part A, Taper Section for Center Conductor

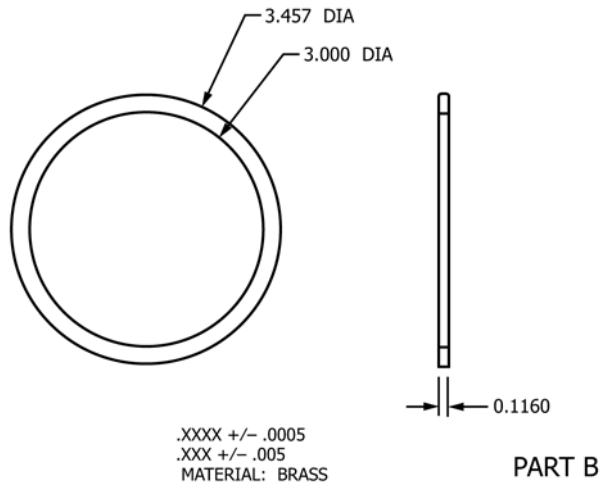

FIG. A1.2 Part B, Pressure Ring for Outer Conductor

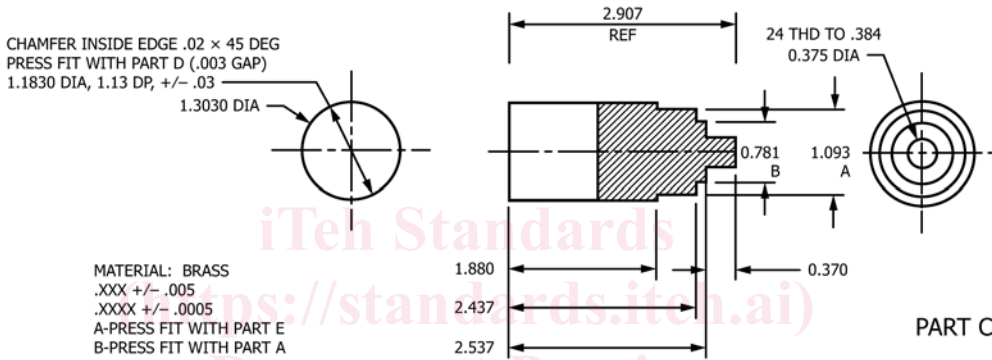

FIG. A1.3 Part C, Straight Part of Center Conductor

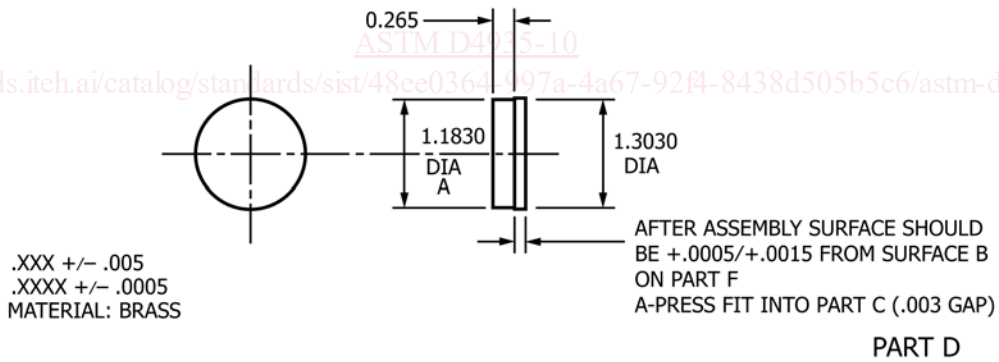

FIG. A1.4 Part D, Pressure Piece for Center Conductor