



SLOVENSKI STANDARD

SIST EN 13889:2004

01-junij-2004

**Kovane jeklene skobe za splošne dvigalne namene – Ravne in zakrivljene skobe –
Kakovostni razred 6 - Varnost**

Forged steel shackles for general lifting purposes - Dee shackles and bow shackles -
Grade 6 - Safety

Geschmiedete Schäkel für allgemeine Hebezwecke - Gerade und geschweifte Schäkel -
Güteklasse 6 - Sicherheit

Manilles forgées en acier pour applications générales levage - Manilles droites et
manilles lyres - Classe 6 - Sécurité

Ta slovenski standard je istoveten z: EN 13889:2003

ICS:

53.020.30 Pribor za dvigalno opremo Accessories for lifting
equipment

SIST EN 13889:2004

en

iTeh STANDARD PREVIEW
(standards.iteh.ai)

[SIST EN 13889:2004](#)

<https://standards.iteh.ai/catalog/standards/sist/38416e40-6dbb-4b4f-a043-93107d15b8ee/sist-en-13889-2004>

EUROPEAN STANDARD

EN 13889

NORME EUROPÉENNE

EUROPÄISCHE NORM

June 2003

ICS 53.020.30

English version

Forged steel shackles for general lifting purposes - Dee shackles and bow shackles - Grade 6 - Safety

Manilles forgées en acier pour applications générales
levage - Manilles droites et manilles lyres - Classe 6 -
Sécurité

Geschmiedete Schäkel für allgemeine Hebezwecke -
Gerade und geschweifte Schäkel - Güteklasse 6 -
Sicherheit

This European Standard was approved by CEN on 25 April 2003.

CEN members are bound to comply with the CEN/CENELEC Internal Regulations which stipulate the conditions for giving this European Standard the status of a national standard without any alteration. Up-to-date lists and bibliographical references concerning such national standards may be obtained on application to the Management Centre or to any CEN member.

This European Standard exists in three official versions (English, French, German). A version in any other language made by translation under the responsibility of a CEN member into its own language and notified to the Management Centre has the same status as the official versions.

CEN members are the national standards bodies of Austria, Belgium, Czech Republic, Denmark, Finland, France, Germany, Greece, Hungary, Iceland, Ireland, Italy, Luxembourg, Malta, Netherlands, Norway, Portugal, Slovakia, Spain, Sweden, Switzerland and United Kingdom.

[SIST EN 13889:2004](https://standards.iteh.ai/catalog/standards/sist/38416e40-6dbb-4b4f-a043-93107d15b8ee/sist-en-13889-2004)

<https://standards.iteh.ai/catalog/standards/sist/38416e40-6dbb-4b4f-a043-93107d15b8ee/sist-en-13889-2004>



EUROPEAN COMMITTEE FOR STANDARDIZATION
COMITÉ EUROPÉEN DE NORMALISATION
EUROPÄISCHES KOMITEE FÜR NORMUNG

Management Centre: rue de Stassart, 36 B-1050 Brussels

Contents

	page
Foreword.....	3
Introduction	4
1 Scope	5
2 Normative references	5
3 Terms and definitions	5
4 Hazards	7
5 Safety requirements	8
6 Verification of safety requirements	14
7 Marking	19
8 Manufacturer's certificate	19
9 Instructions for use	20
Annex A (informative) Safe use of shackles	21
Annex B (normative) Shackle pins	26
Annex C (informative) Designation system for forged steel shackles	27
Annex ZA (informative) Relationship of this European Standard with EU Directives	28
Bibliography	29

[SIST EN 13889:2004](https://standards.iteh.ai/catalog/standards/sist/58416e40-6d6b-4641-a043-93107d15b8ee/sist-en-13889-2004)
<https://standards.iteh.ai/catalog/standards/sist/58416e40-6d6b-4641-a043-93107d15b8ee/sist-en-13889-2004>

Foreword

This document (EN 13889:2003) has been prepared by Technical Committee CEN /TC 168, "Chains, ropes, webbing, slings and accessories - Safety" the secretariat of which is held by BSI.

This European Standard shall be given the status of a national standard, either by publication of an identical text or by endorsement, at the latest by December 2003, and conflicting national standards shall be withdrawn at the latest by December 2003.

This document has been prepared under a mandate given to CEN by the European Commission and the European Free Trade Association, and supports essential requirements of EC Directive(s).

For relationship with EC Directive(s), see informative annex ZA, which is an integral part of this document.

Annexes A and C are informative. Annex B is normative.

According to the CEN/CENELEC Internal Regulations, the national standards organizations of the following countries are bound to implement this European Standard: Austria, Belgium, Czech Republic, Denmark, Finland, France, Germany, Greece, Hungary, Iceland, Ireland, Italy, Luxembourg, Malta, Netherlands, Norway, Portugal, Slovakia, Spain, Sweden, Switzerland and the United Kingdom.

iTeh STANDARD PREVIEW
(standards.iteh.ai)

[SIST EN 13889:2004](https://standards.iteh.ai/catalog/standards/sist/38416e40-6dbb-4b4f-a043-93107d15b8ee/sist-en-13889-2004)

<https://standards.iteh.ai/catalog/standards/sist/38416e40-6dbb-4b4f-a043-93107d15b8ee/sist-en-13889-2004>

Introduction

This European Standard has been prepared to be a harmonised standard to provide one means of conforming with the essential safety requirements of the Machinery Directive and associated EFTA regulations.

The extent to which hazards are covered is indicated in the scope. In addition, lifting equipment will conform as appropriate to EN 292 for hazards that are not covered by this standard.

The designation system given in annex C for recording the identifying features of forged steel shackles has been included in this first edition of this standard as an informative annex. However, should its use become accepted then the status of the annex will need to be reviewed.

iTeh STANDARD PREVIEW (standards.iteh.ai)

[SIST EN 13889:2004](https://standards.iteh.ai/catalog/standards/sist/38416e40-6dbb-4b4f-a043-93107d15b8ee/sist-en-13889-2004)

<https://standards.iteh.ai/catalog/standards/sist/38416e40-6dbb-4b4f-a043-93107d15b8ee/sist-en-13889-2004>

1 Scope

This European Standard specifies requirements for forged steel Dee and bow shackles of grade 6 for general lifting purposes in a range of working load limits 0,5 t to 25 t maximum.

This standard applies only to those shackles with threaded pins.

Annex A gives information on the safe use of shackles, annex B gives information on types of pins, and annex C gives an example of a designation system for forged steel shackles.

The hazards covered are identified in clause 4.

2 Normative references

This European Standard incorporates by dated or undated reference provisions from other publications. These normative references are cited at appropriate places in the text, and the publications are listed hereafter. For dated references, subsequent amendments to, or revisions of, any of these publications apply to this European Standard only when incorporated in it by amendment or revision. For undated references the latest edition of the publication referred to applies (including amendments).

EN 292-2: 1991, *Safety of machinery — Basic concepts, general principles for design - Part 2: Technical principles and specifications*

EN 1050: 1996, *Safety of machinery — Principles for risk assessment*

EN 10025: 1990, *Hot rolled products of non-alloy structural steels — Technical delivery conditions*

EN 10045-1, *Metallic materials — Charpy impact test — Part 1: Test method*

EN 10045-2, *Metallic materials — Charpy impact test — Part 2: Verification of the testing machine (pendulum impact)*

EN 10228-1, *Non-destructive testing of steel forgings — Part 1: Magnetic particle inspection*

EN 10228-2, *Non-destructive testing of steel forgings — Part 2: Penetrant testing*

EN 45012, *General requirements for bodies operating assessment and certification/registration of quality systems (ISO/IEC Guide 62:1996)*

EN ISO 7500-1: 1999, *Metallic materials — Verification of static uniaxial testing machines — Part 1: Tension/compression testing machines - Verification and calibration of the force-measuring system. (ISO 7500-1:1999)*

ISO 261, *ISO general-purpose metric screw threads — General plan*

ISO 263, *ISO inch screw threads — General plan and selection for screws, bolts and nuts — Diameter range 0.06 to 6 inch*

ISO 643, *Steels — Micrographic determination of the apparent grain size*

3 Terms and definitions

For the purposes of this European Standard the terms and definitions given in EN 10025: 1990 and the following apply:

EN 13889:2003 (E)**3.1****shackle**

a lifting accessory comprising a body and pin as shown in Figures 1 and 2 which are readily separable and can be used to connect a load to a lifting machine directly or in conjunction with other lifting accessories.

3.2**body**

a part of the shackle formed to the shape of a dee or bow and terminating in eyes as shown in Figures 1 and 2.

3.3**pin**

a component of circular section which passes through the eyes of the shackle, as shown in Figures 1, 2 and B.1 and which can be readily disassembled.

3.4**dee shackle**

a shackle the crown of which forms a semicircle of internal radius half the width, W , between the eyes as shown in Figure 1.

3.5**bow shackle**

a shackle the crown of which forms more than a semicircle of internal radius more than half the width, W , between the eyes as shown in Figure 2.

3.6**working load limit WLL**

maximum mass that a shackle is authorized to sustain in general service

NOTE This term has the same meaning as the term maximum working load used in EN 292-2: 1991, annex A.

3.7**manufacturing proof force MPF**

force applied to the shackle during the manufacturing proof test

3.8**breaking force BF**

maximum force reached during the static tensile test of a shackle at which the shackle fails to retain the load

3.9**traceability code**

series of letters and/or numbers marked on a shackle that enables its manufacturing history, including identity of the cast of steel used, to be traced

3.10**lot**

number of shackles of the same type and dimensions, manufactured during the same production run from the same cast of steel and subjected to the same heat treatment process

3.11**type W pin**

screwed pin with eye and collar and which screws into one eye of the shackle body

3.12**type X pin**

bolt type pin with hexagon head, hexagon nut and split cotter pin

3.13**competent person**

designated person, suitably trained, qualified by knowledge and practical experience, and with the necessary instruction to enable the required test and examination to be carried out

NOTE EN ISO 9001 gives guidance on training.

4 Hazards

Accidental release of a load, or release of a load due to failure of shackle puts at risk, either directly or indirectly the safety or health of those persons within the danger zone.

In order to provide the necessary strength and durability of shackles EN 13889 gives requirements for the design, manufacture and testing to ensure the specified levels of performance are met.

Since failure can be caused by the incorrect choice of grade and specification of shackle EN 13889 also gives the requirements for marking and the manufacturer's certificate.

Errors of fitting can also lead to failure and EN 13889 contains dimensional requirements to allow correct fit.

Risk of injury due to sharp edges, sharp angles or rough surfaces when handling is also covered by this standard.

Those aspects of safe use associated with good practice are given in annex A.

Table 1 contains those hazards, which require action to reduce risk identified by risk assessment as being specific and significant for shackles.

Table 1 — Hazards and associated requirements

Hazards identified in annex A EN 1050: 1996,		Relevant clause of annex A of EN 292- 2: 1991	Relevant clause/ subclause of EN 13889
1	Mechanical hazard due to inadequacy of strength	1.3.2 4.1.2.3 1.3.2 4.1.2.3 4.1.2.5 4.2.4 4.3.2 4.2.4 1.7.4	5 5 5 6 7 8 9
1.3	Cutting hazard	1.3.4	5.3
1.8	Friction or abrasion hazard	1.3.4	5.3
15	Errors of fitting hazard	1.5.4	5.1

5 Safety requirements

5.1 Dimensions

5.1.1 Dee shackles

The principal dimensions of the dee shackle shall conform to Table 2 in which the dimensions are related to the working load limit.

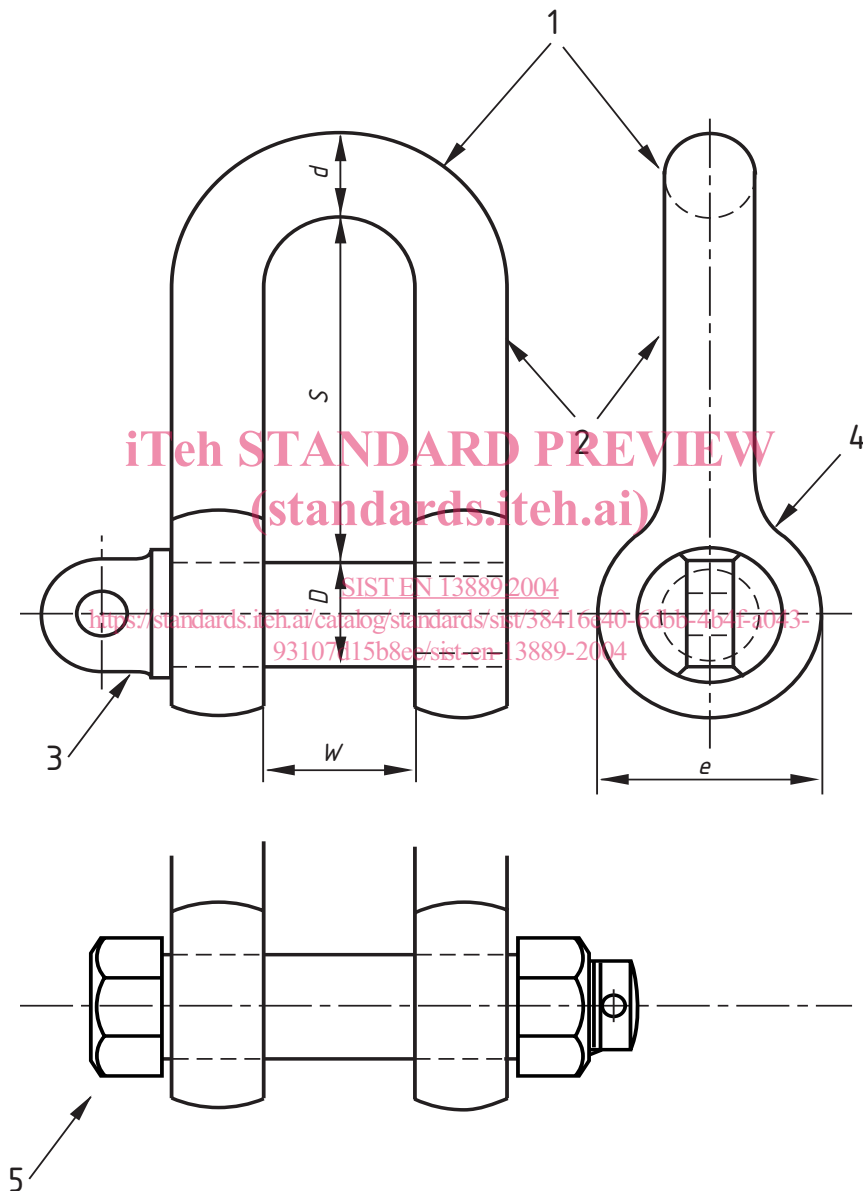

Key:

- 1 Crown
- 2 Body
- 3 Example of screwed pin with eye and collar – type W
- 4 Eye
- 5 Bolt type pin with hexagon head, hexagon nut and split cotter pin – type X

Figure 1 — Dimensions of dee shackles

5.1.2 Bow shackles

The principal dimensions of the bow shackle shall conform to Table 2 in which the dimensions are related to the working load limit.

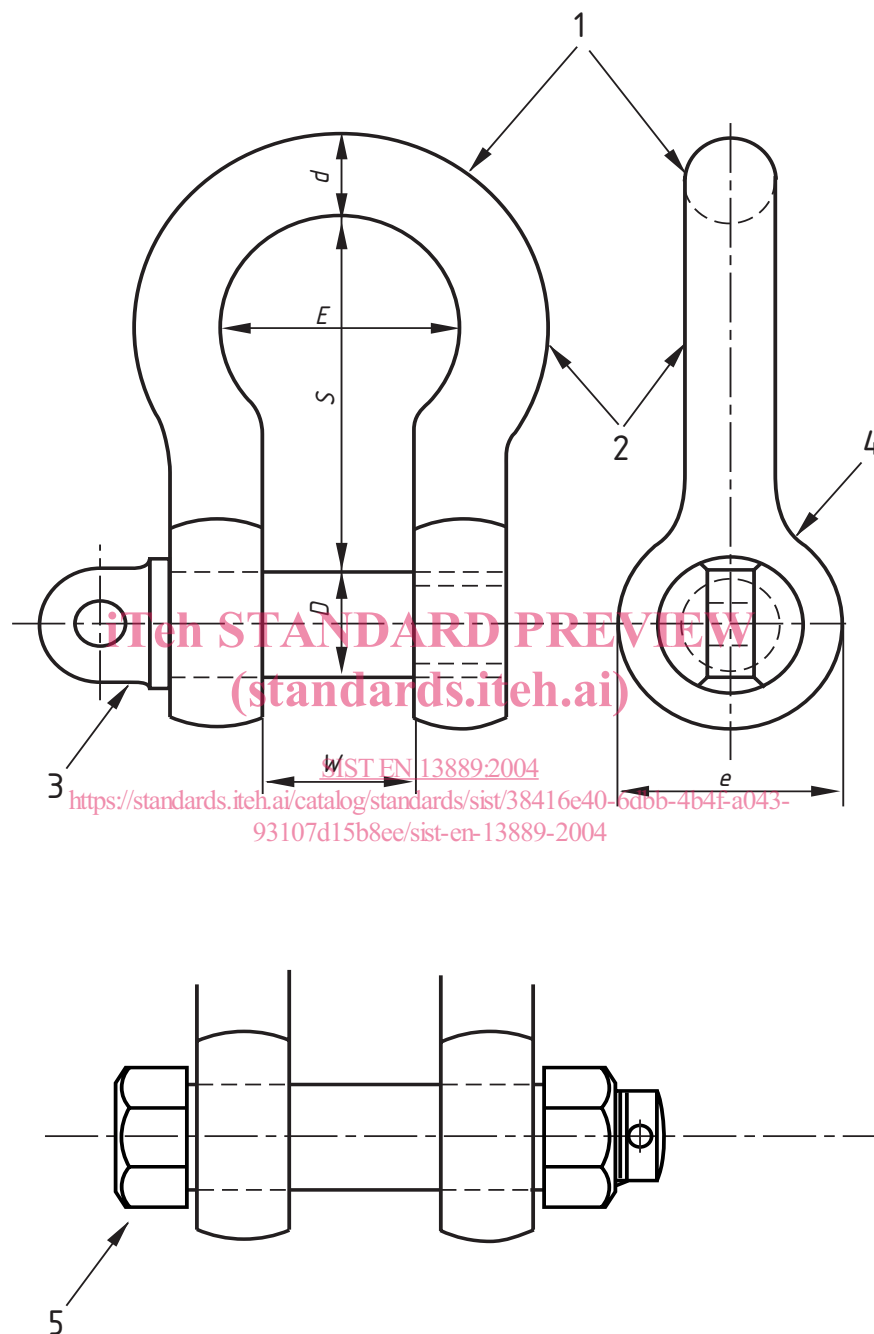

Key:

- 1 Crown
- 2 Body
- 3 Example of screwed pin with eye and collar – type W
- 4 Eye
- 5 Bolt type pin with hexagon head, hexagon nut and split cotter pin – type X

Figure 2 — Dimensions of Bow shackles

Table 2 — Limiting values for Dee shackles and Bow shackles

WLL	Nominal bow diameter d_n	Nominal pin diameter D_n	Nominal inside width W_n at pin	Minimum eye diameter e_n	Dee shackle: minimum inside length S	Bow shackle: minimum inside length S	Minimum inside width of bow E_{min}
t	mm	mm	mm	mm	mm	mm	mm
0,5	6,50	8	12	15,5	20	27	19
0,75	8	9,5	13,5	18,5	25	29	20
1	10	11	16,5	22	27	32	24
1,5	11,2	12,2	19	25	33	39	27
2	13,5	16	21,5	29,5	38	44	30
3,25	16,5	19	27	38	47	57	39
4,75	20	22	31,5	44	52	65	48
6,5	23	25	36,5	50	65	76	55
8,5	25,5	28	43	56	74	88	64
9,5	29	32	46,5	64	83	101	70
12	33	35	51,5	70	87	108	78
13,5	36,5	38	57	76	104	126	85
17	39,5	42	60	84	115	139	94
25	46	51	74	100	139	168	119
NOTE: Tolerances:							
- Bow dia, d_n : 0,5 t up to and including 2 t : +1,5/ - 1 mm							
: 3,25 t up to and including 12 t : +/- 2,5 mm							
: 13,5 t up to and including 25 t : +/- 3 mm							
Allow bow diameter d_n to be oval, + 10 % (for sizes 3,25 t up to and including 17 t, + 25 % for size 25 t (same tolerances as above)							
- Pin dia, D_n : 0,5 t up to and including 2 t : +/- 1 mm							
: 3,25 t up to and including 25 t : +/- 2 mm							
- Inside width at pin, W_n : 0,5 t up to and including 2 t : +/- 2,5 mm							
: 3,25 t up to and including 9,5 t : +/- 3 mm							
: 12 t up to and including 25 t : +/- 4 mm							

5.2 Design

5.2.1 Screw threads

Screw threads shall conform either to ISO 261 class 7H/8g or to ISO 263 class 1A/1B.

NOTE For hot dip galvanized or coated pins it is permissible for the threads to be undercut prior to galvanizing or coating.