

---

---

**Plastics piping systems — Glass-reinforced thermosetting plastics (GRP) pipes — System design of above ground pipe and joint installations without end thrust**

*Systèmes de canalisations en plastiques — Tubes en plastiques thermodurcissables renforcés de verre (PRV) — Conception de système d'installations de tubes et d'assemblages en aérien sans poussée d'extrémité*

(<https://standards.iteh.ai>)  
Document Preview

[ISO/TS 10986:2021](https://standards.iteh.ai/catalog/standards/iso/b91909c6-4046-4ed6-ba29-f76480980869/iso-ts-10986-2021)

<https://standards.iteh.ai/catalog/standards/iso/b91909c6-4046-4ed6-ba29-f76480980869/iso-ts-10986-2021>



iTeh Standards  
(<https://standards.iteh.ai>)  
Document Preview

[ISO/TS 10986:2021](https://standards.iteh.ai/catalog/standards/iso/b91909c6-4046-4ed6-ba29-f76480980869/iso-ts-10986-2021)

<https://standards.iteh.ai/catalog/standards/iso/b91909c6-4046-4ed6-ba29-f76480980869/iso-ts-10986-2021>



**COPYRIGHT PROTECTED DOCUMENT**

© ISO 2021

All rights reserved. Unless otherwise specified, or required in the context of its implementation, no part of this publication may be reproduced or utilized otherwise in any form or by any means, electronic or mechanical, including photocopying, or posting on the internet or an intranet, without prior written permission. Permission can be requested from either ISO at the address below or ISO's member body in the country of the requester.

ISO copyright office  
CP 401 • Ch. de Blandonnet 8  
CH-1214 Vernier, Geneva  
Phone: +41 22 749 01 11  
Email: [copyright@iso.org](mailto:copyright@iso.org)  
Website: [www.iso.org](http://www.iso.org)

Published in Switzerland

# Contents

Page

<b>Foreword</b> .....	<b>iv</b>
<b>Introduction</b> .....	<b>v</b>
<b>1 Scope</b> .....	<b>1</b>
<b>2 Normative references</b> .....	<b>1</b>
<b>3 Terms and definitions</b> .....	<b>1</b>
<b>4 Angular deflection of joints</b> .....	<b>1</b>
4.1 General.....	1
4.2 Effects of loads on joint angular deflection.....	3
4.3 Measuring deflections.....	3
4.4 Checking the installed joint.....	4
4.4.1 General.....	4
4.4.2 Coupling-to-pipe position.....	4
4.4.3 Joint misalignment.....	5
4.4.4 Gap between pipe ends.....	5
4.4.5 Adjusting joints.....	6
<b>5 Installation of above ground pipes</b> .....	<b>6</b>
5.1 General.....	6
5.2 Supporting of pipes.....	7
5.2.1 General.....	7
5.2.2 Support design.....	9
5.2.3 Loads on supports.....	10
5.3 Anchor design.....	11
5.4 Guide design.....	11
5.5 Maximum support spacing.....	14
5.5.1 General.....	14
5.5.2 Perpendicular forces.....	15
5.5.3 Forces due to angular deviation.....	15
5.5.4 Axial forces.....	15
5.5.5 Maximum total axial force.....	17
5.5.6 Deformations and bending moments for pipes resting on two supports.....	18
5.5.7 Deformations and bending moments for pipes resting on multiple supports.....	21
5.5.8 Load cases and combinations of long- and short-term loads.....	23
5.5.9 Checking of stresses and deformations.....	24
<b>Annex A (informative) Pipeline pressure testing and inspection</b> .....	<b>27</b>
<b>Annex B (informative) Recording above ground joint deflection data</b> .....	<b>34</b>
<b>Bibliography</b> .....	<b>37</b>

## Foreword

ISO (the International Organization for Standardization) is a worldwide federation of national standards bodies (ISO member bodies). The work of preparing International Standards is normally carried out through ISO technical committees. Each member body interested in a subject for which a technical committee has been established has the right to be represented on that committee. International organizations, governmental and non-governmental, in liaison with ISO, also take part in the work. ISO collaborates closely with the International Electrotechnical Commission (IEC) on all matters of electrotechnical standardization.

The procedures used to develop this document and those intended for its further maintenance are described in the ISO/IEC Directives, Part 1. In particular, the different approval criteria needed for the different types of ISO documents should be noted. This document was drafted in accordance with the editorial rules of the ISO/IEC Directives, Part 2 (see [www.iso.org/directives](http://www.iso.org/directives)).

Attention is drawn to the possibility that some of the elements of this document may be the subject of patent rights. ISO shall not be held responsible for identifying any or all such patent rights. Details of any patent rights identified during the development of the document will be in the Introduction and/or on the ISO list of patent declarations received (see [www.iso.org/patents](http://www.iso.org/patents)).

Any trade name used in this document is information given for the convenience of users and does not constitute an endorsement.

For an explanation of the voluntary nature of standards, the meaning of ISO specific terms and expressions related to conformity assessment, as well as information about ISO's adherence to the World Trade Organization (WTO) principles in the Technical Barriers to Trade (TBT), see [www.iso.org/iso/foreword.html](http://www.iso.org/iso/foreword.html).

This document was prepared by Technical Committee ISO/TC 138, *Plastics pipes, fittings and valves for the transport of fluids*, Subcommittee SC 6, *Reinforced plastics pipes and fittings for all applications*.

Any feedback or questions on this document should be directed to the user's national standards body. A complete listing of these bodies can be found at [www.iso.org/members.html](http://www.iso.org/members.html).

<https://standards.iteh.ai/catalog/standards/iso/b91909c6-4046-4ed6-ba29-f76480980869/iso-ts-10986-2021>

## Introduction

While pipes manufactured according to ISO 23856 are typically utilized in buried installations, there are circumstances where installing above ground is the preferred practice. These can include terrain not suitable for burial (e.g. rock), road or river crossings, unsuitable soils and installation on steep slopes.

For information on subjects such as shipping, handling, inspecting, rigid connections, thrust restraint and joining pipes, refer to ISO/TS 10465-1 which addresses the buried installation of GRP pipes. The guidelines and information on these subjects are also applicable to pipes used above ground. The information in this document is intended to supplement ISO/TS 10465-1 with practices and guidelines specific to above ground installation.

iTeh Standards  
(<https://standards.iteh.ai>)  
Document Preview

[ISO/TS 10986:2021](https://standards.iteh.ai/catalog/standards/iso/b91909c6-4046-4ed6-ba29-f76480980869/iso-ts-10986-2021)

<https://standards.iteh.ai/catalog/standards/iso/b91909c6-4046-4ed6-ba29-f76480980869/iso-ts-10986-2021>



# Plastics piping systems — Glass-reinforced thermosetting plastics (GRP) pipes — System design of above ground pipe and joint installations without end thrust

## 1 Scope

This document addresses the system design of pipe and joints of above ground installations without end-thrust as specified in systems standard ISO 23856. It is directed to pipelines with a minimum stiffness of SN 5000 laid in a straight line between thrust blocks. It is based on the safety concepts described in ISO TS 20656-1, with consequence class 2 (CC2) as default. For other consequence classes, certain details specified in this document can need to be modified. This document is directed to double bell coupling. However, much of the information can be adapted and utilized for other flexible joints systems.

This document does not cover fittings nor detailed engineering work like thrust blocks, support and anchor designs.

As installation is not included in the scope of this document and to assist system design, [Annex A](#) provides a pressure testing and inspection procedure. However, to ensure the use of clearly defined field test data in system design, [Annex A](#) can be used normatively by agreement between purchaser and supplier. An example of recording above ground joint deflection data is given in [Annex B](#).

## 2 Normative references

There are no normative references in this document.

## 3 Terms and definitions

No terms and definitions are listed in this document.

ISO and IEC maintain terminological databases for use in standardization at the following addresses:

- ISO Online browsing platform: available at <https://www.iso.org/obp>
- IEC Electropedia: available at <http://www.electropedia.org/>

## 4 Angular deflection of joints

### 4.1 General

The angular deflection at flexible joints shall be controlled to avoid excessive loads on the pipeline and its supporting structures. Above ground installations do not benefit from the stabilizing support that is given by the soil in buried installations, and they are therefore more susceptible to problems of joint misalignment. For this reason, control and measurement of joint angular deflection is of great importance. It is necessary to limit angular deflections to lower values than those normally permitted for buried applications.

There are two types of deflection to consider: pipe-to-pipe angular deflection and coupling-to-pipe deflection, as shown in [Figure 1](#). Both need to be considered as coupling-to-pipe angular deflection can be larger than the pipe-to-pipe angular deflection.

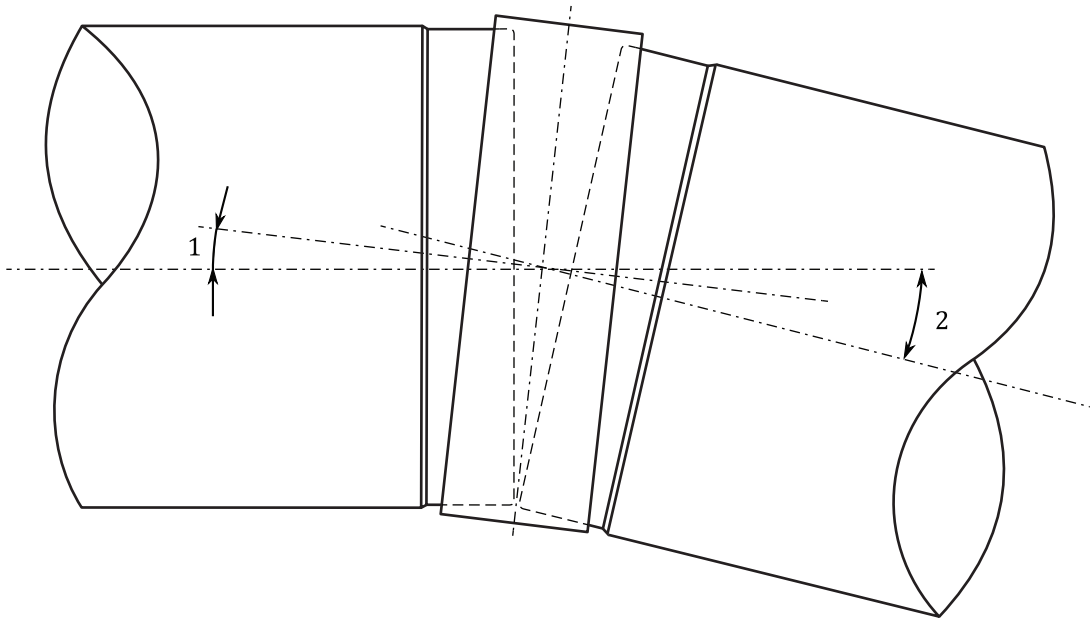

**Key**

- 1 coupling-to-pipe angular deflection
- 2 pipe-to-pipe angular deflection

**Figure 1 — "Pipe-to-pipe" and "coupling-to-pipe" deflection, example 1**

For some designs of double socket joint the pipe can only move on one side of the coupling. In that case, the pipe-to-pipe angular deflection is equal to the coupling-to-pipe angular deflection on one side (see [Figure 2](#)). The manufacturer should advise which case will occur with their design of joint.

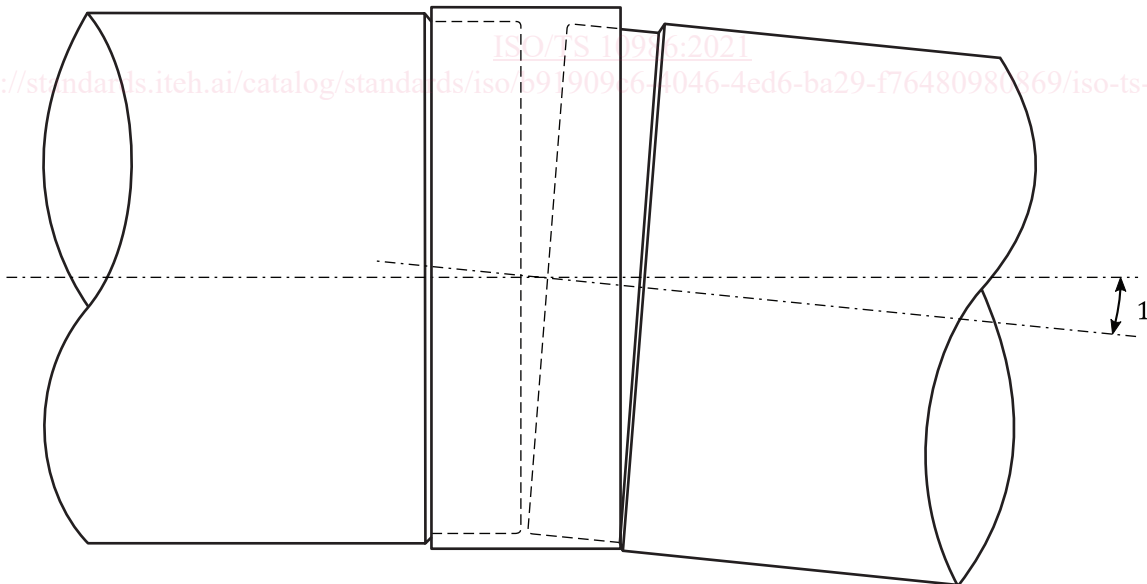

**Key**

- 1 pipe-to-pipe = pipe-to-coupling angular deflection

**Figure 2 — "Pipe-to-pipe" and "coupling-to-pipe" deflection, example 2**



## 4.2 Effects of loads on joint angular deflection

The angular deflection is influenced by several factors in addition to the initial pipe installation, such as load-induced pipe deflections and support settlement.

Pipe deflections after initial installation are caused by forces produced by the weight of fluid in the pipe, external loads and pressure within the pipeline. These forces can produce significant pipe-to-coupling deflections which, if acting in a similar plane to the initial installation deflection, can result in the total deflection at the coupling exceeding the allowable limit. An example of this effect is shown in [Figure A.3](#).

The initial pipe angular deflection therefore should be limited to allow for this effect to ensure that the total deflection does not exceed the maximum coupling deflection specification.

## 4.3 Measuring deflections

The coupling-to-pipe angular deflection is measured as an angular offset, see [Figure 3](#).

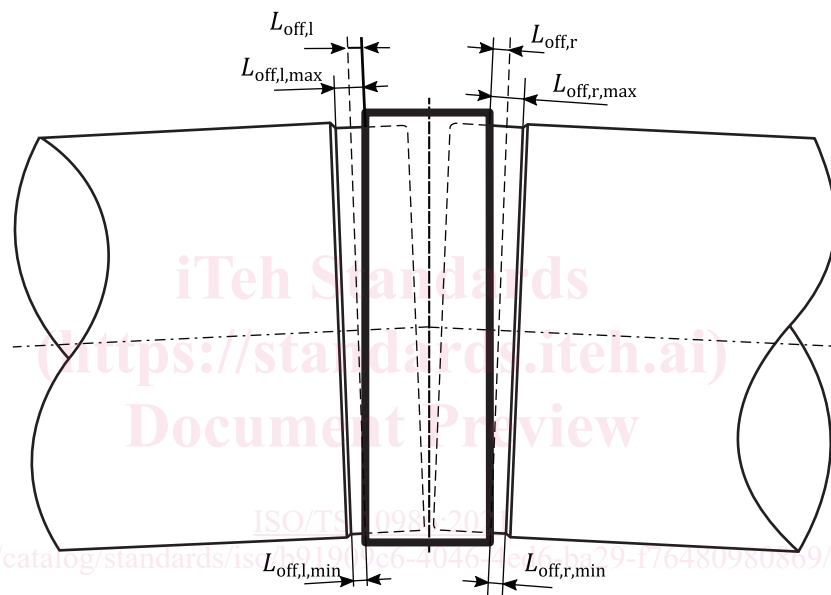

### Key

$L_{off,l}$  coupling offset (left pipe) =  $L_{off,l,max} - L_{off,l,min}$

$L_{off,r}$  coupling offset (right pipe) =  $L_{off,r,max} - L_{off,r,min}$

$L_{off,l,min}$  minimum coupling offset (left pipe)

$L_{off,l,max}$  maximum coupling offset (left pipe)

$L_{off,r,min}$  minimum coupling offset (right pipe)

$L_{off,r,max}$  maximum coupling offset (right pipe)

**Figure 3 — Measurements for determining the angular offset**

Coupling offsets  $L_{off,l}$  and  $L_{off,r}$  should be measured as follows:

Find the maximum and the minimum distance between the homeline and the face of the coupling along the circumference of the pipe. Subtract the minimum found value from the maximum found value.

The total pipe-to-pipe offset,  $L_{off,tot}$ , is calculated by additioning  $L_{off,l}$  and  $L_{off,r}$ , see [Formula \(1\)](#):

$$L_{off,tot} = L_{off,l} + L_{off,r} \tag{1}$$

The total pipe-to-pipe offset,  $L_{off,tot}$ , shall be smaller or equal to the maximum allowable coupling offset  $L_{off,max}$ , see [Formula \(2\)](#):

$$L_{off,tot} \leq L_{off,max} \tag{2}$$

with [Formula \(3\)](#):

$$L_{off,max} = DN \cdot \frac{\alpha_{max} \pi}{180} \tag{3}$$

NOTE [Formula \(1\)](#) and [Formula \(2\)](#) are only valid for conditions given in [Figure 3](#), but not for conditions seen in [Figure 9](#), where the coupling-to-pipe angular deflection is larger than the pipe-to-pipe angular deflection. However, the same logic applies.

The maximum pipe-to-pipe offset for empty pipes installed in straight alignment is shown in [Table 1](#).

**Table 1 — Maximum pipe-to-pipe offset for pressure pipes installed in straight alignment**

Pipe nominal size DN	Declared allowable joint (pipe-to-pipe) angular deflection, $\alpha_{max}$ in degrees	Maximum allowable installed angular deflection, $\alpha$ , in degrees (not filled, no pressure)	Example	
			DN	Maximum value ( $L_{off,l} + L_{off,r}$ ) in mm
$\leq 500$	3	1	500	9
$500 < DN \leq 900$	2	2/3	900	10
$900 < DN \leq 1\,800$	1	1/3	1\,800	10
$> 1\,800$	0,5	1/6	3\,600	10

In service, the following factors cause an increase in the angle,  $\alpha$ , and as a result,  $L_{off,tot}$ :

- weight of water
- pressurizing
- creep in the pipe material.

See [5.5.9.3](#) for further details.

#### 4.4 Checking the installed joint

##### 4.4.1 General

The quality of the joint installation should be checked as soon as possible after assembly as correction can be difficult when the coupling gaskets have settled. Information regarding forms that can be used for recording the joint quality control is given in [Annex B](#).

The installed joint should be checked at normal ambient temperatures. High or uneven pipe temperatures as can be caused by direct sunlight, for example, affect the results of the checks.

##### 4.4.2 Coupling-to-pipe position

It is important for the coupling to be located as centrally as possible between the two pipe ends in order to avoid interference of the pipe end with the gasket or the pipe ends touching during operation.

#### 4.4.3 Joint misalignment

Maximum misalignment of pipe ends should not exceed the lesser of 0,5 % of pipe diameter or 3 mm. The misalignment can be measured with two identical notched rulers pressed against the pipe at both sides of the coupling, see [Figure 4](#). If the depth of the machined spigot surface is different for the two pipes, the measured misalignment should be corrected accordingly. For pipes 700 mm and larger the misalignment can be measured with a ruler from the inside of the pipe, see [Figure 4](#).

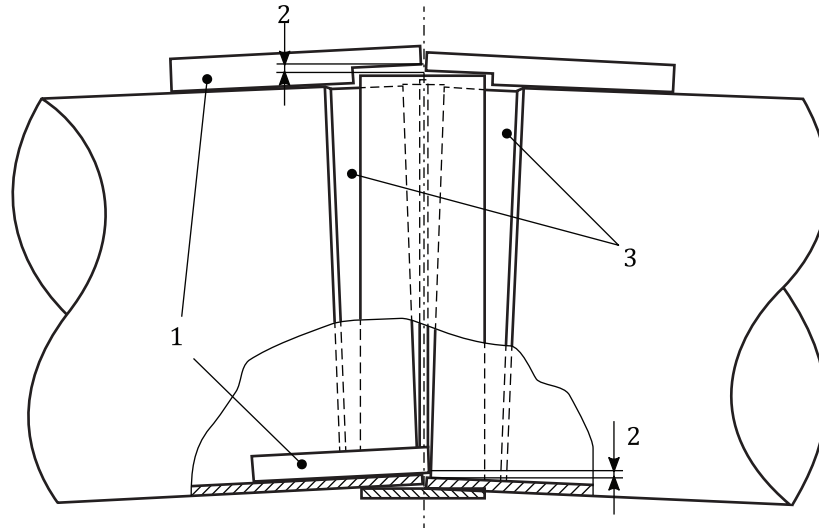

#### Key

- 1 rulers
- 2 joint misalignment
- 3 machined spigot surfaces (measure gaps between rulers and spigot surface)

NOTE On some pipes there is no machined spigot surface, either because it is not designed to have one or because it is negligible because the pipe barrel OD is the correct spigot diameter.

<https://standards.iteh.ai/catalog/standards/iso/b91909c6-4046-4ed6-ba29-f76480980869/iso-ts-10986-2021>  
**Figure 4 — Misalignment**

#### 4.4.4 Gap between pipe ends

The gap between pipe ends is checked by measuring the distance between the homelines (see [Figure 5](#)). The gap,  $d_g$ , is then calculated using [Formulae \(4\)](#) and [\(5\)](#):

$$d_{g,\min} = d_{\min} - 2d_1 \quad (4)$$

$$d_{g,\max} = d_{\max} - 2d_1 \quad (5)$$

where

$d_{g,\min}$  is the minimum measured gap between pipe ends;

$d_{g,\max}$  is the maximum measured gap between pipe ends;

$d_{\min}$  is the minimum measured distance between homelines;

$d_{\max}$  is the maximum measured distance between homelines;

$d_1$  is the distance from the pipe end to the homeline

The engineer should decide what the value of the gap should be, based on maximum and minimum allowable draw and installation and service conditions. These include at least increased rotation due to weight of water and effects of pressure and creep, Poisson’s effect and temperature change.

The distance from the pipe end to the homeline,  $d_1$ , can be found in the pipe specifications or measured prior to installation, see [Figure 5](#).

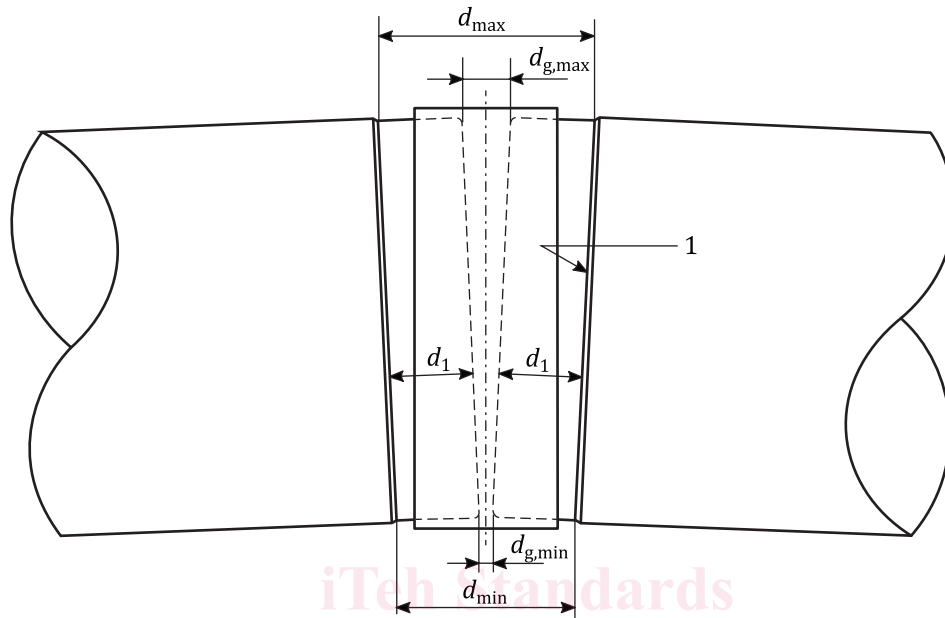

**Key**

- 1 homeline
- $d_1$  distance of homeline from end of pipe
- $d_{min}$  minimum measured distance between homelines
- $d_{g,min}$  minimum measured gap between pipe ends
- $d_{max}$  maximum measured distance between homelines
- $d_{g,max}$  maximum measured gap between pipe ends

**Figure 5 — Gap between pipe ends**

For pipes 700 mm and larger the gap can be measured directly from the inside of the pipe.

**4.4.5 Adjusting joints**

The joint should be adjusted if any of the checks described in the preceding clauses fall outside the specified limits. The necessary adjustments of coupling or pipe position should be made carefully, avoiding concentrated loads or impact loads that can damage the pipe or the coupling.

**5 Installation of above ground pipes**

**5.1 General**

The designer of an above ground pipe installation should be aware of the forces that act on the pipe system, particularly where high system pressures exist.

When a component in a pressurized pipeline has a change in cross-sectional area or alignment direction, a resultant force is induced. All components such as bends, reducers, tees, wyes or valves shall be anchored or restrained to withstand these loads. This is the case for above ground as well as buried pipes.

In buried pipelines, adequate resistance to movements at joints in undeflected installations is generally provided by the pipe embedment. Such resistance shall be provided at the supports of an above ground