



Standard Test Method for Blocking and Picking Points of Petroleum Wax¹

This standard is issued under the fixed designation D1465; the number immediately following the designation indicates the year of original adoption or, in the case of revision, the year of last revision. A number in parentheses indicates the year of last reapproval. A superscript epsilon (ϵ) indicates an editorial change since the last revision or reapproval.

1. Scope*

1.1 This test method covers the determination of the blocking point and picking point of petroleum wax.

1.2 **WARNING**—Mercury has been designated by many regulatory agencies as a hazardous material that can cause central nervous system, kidney and liver damage. Mercury, or its vapor, may be hazardous to health and corrosive to materials. Caution should be taken when handling mercury and mercury containing products. See the applicable product Material Safety Data Sheet (MSDS) for details and EPA's website—<http://www.epa.gov/mercury/faq.htm>—for additional information. Users should be aware that selling mercury and/or mercury containing products into your state or country may be prohibited by law.

1.3 The values stated in SI units are to be regarded as standard. The values given in parentheses are provided for information only.

1.4 *This standard does not purport to address all of the safety concerns, if any, associated with its use. It is the responsibility of the user of this standard to establish appropriate safety and health practices and determine the applicability of regulatory limitations prior to use.*

2. Referenced Documents

2.1 *ASTM Standards:*²

[D87 Test Method for Melting Point of Petroleum Wax \(Cooling Curve\)](#)

[D938 Test Method for Congealing Point of Petroleum Waxes, Including Petrolatum](#)

[D2423 Test Method for Surface Wax on Waxed Paper or Paperboard](#)

¹ This test method is under the jurisdiction of ASTM Committee D02 on Petroleum Products, Liquid Fuels, and Lubricants and is the direct responsibility of Subcommittee D02.10.0A on Physical/Chemical Properties. This test method was prepared jointly by the Technical Association of the Pulp and Paper Industry and the American Society for Testing and Materials.

Current edition approved May 1, 2010. Published June 2010. Originally approved in 1957. Last previous edition approved in 2004 as D1465–04. DOI: 10.1520/D1465-10.

² For referenced ASTM standards, visit the ASTM website, www.astm.org, or contact ASTM Customer Service at service@astm.org. For *Annual Book of ASTM Standards* volume information, refer to the standard's Document Summary page on the ASTM website.

E1 Specification for ASTM Liquid-in-Glass Thermometers

3. Terminology

3.1 *Definitions:*

3.1.1 *wax blocking point*—the lowest temperature at which film disruption occurs across 50 % of the waxed paper surface when the test strips are separated.

3.1.2 *wax picking point*—the temperature at which the first film disruption occurs on the waxed paper when test strips are separated.

4. Summary of Test Method

4.1 Paper test specimens are coated with the wax sample, folded with the waxed surfaces together, and placed on a blocking plate. The plate is heated at one end and cooled at the other end to impose a measured temperature gradient along its length. After a conditioning period on the plate, the specimens are removed, unfolded, and examined. The points of initial film disruption (picking point) and where 50 % of the specimen width is disrupted (50 % blocking point) are noted. The temperatures of corresponding points on the blocking plate are reported as the picking point and blocking point or blocking range.

5. Significance and Use

5.1 Blocking of waxed paper, because of the relatively low temperatures at which it may occur, can be a major problem to the paper-coating industry. For example, when the waxed surfaces in a roll of waxed paper stick together, upon separation the surface films are marred and the glossy finish is destroyed. The wax picking point and the wax blocking point indicate an approximate temperature range at or above which waxed surfaces in contact with each other are likely to cause surface film injury.

6. Apparatus

6.1 *Wax Coating Device*—Any manual- or machine-driven waxer that gives uniform coatings of the desired weights to a strip of paper not less than 51 mm (2 in.) wide.

6.2 *Trimming Board*, or other device for cutting paper strips.

6.3 *Paper Scales*, sensitive to 0.002 g, or suitable balance for measuring basis weights of unwaxed and waxed paper.

*A Summary of Changes section appears at the end of this standard

6.4 *Blocking Plate Assembly*, consisting of a metal plate 305 mm (12 in.) wide, 13 to 51 mm (½ to 2 in.) thick, and 559 to 914 mm (22 to 36 in.) long. It is heated at one end and cooled at the other end to provide a 457 to 762-mm (18 to 30-in.) test section having an average temperature gradient of 0.8 to 2.2°C (1.5 to 4.0°F)/in. The temperature gradient across the width of the plate from the longitudinal axis to 25 mm (1 in.) from the edge must not exceed 0.3°C (0.5°F). The temperature at any point should not vary more than 0.3°C (0.5°F). Details of two acceptable blocking plates are given in Fig. 1 and Fig. 2.

6.4.1 *Eight Foam Rubber Strips*, 25 to 38 mm (1 to 1½ in.) wide by 6 to 13 mm (¼ to ½ in.) thick, extending the length of the test section on the blocking plate.

6.4.2 *Eight Sets of Steel Weights*, 25 by 25 mm (1 by 1 in.) in cross section made from stock having a density range from 7800 to 8000 kg/m³ (0.28 to 0.29 lb/in³). The weights may be in single lengths or in sections to give sets equaling the length of the test section of the blocking plate.

6.5 *Temperature Recorder*, or indicator for measuring the temperature gradient of the blocking plate. The instrument and thermocouples when calibrated shall consistently be accurate to ± 0.3°C (0.5°F).

6.6 *Temperature Measuring Devices:*

6.6.1 *Thermometers*—For water bath and wax bath on the waxing device, use two ASTM Tag Closed Tester Thermometers having a range from -5 to 110°C (20 to 230°F), graduated in 0.5°C (1°F) subdivisions, and conforming to Thermometer 9C or 9F as prescribed in Specification E1.

6.6.2 Alternatively, bath temperatures may be monitored with a calibrated thermometer containing a liquid other than mercury or an electronic temperature measuring device of equivalent precision and accuracy to the thermometers described in 6.6.1.

7. Test Paper

7.1 *Paper*—Cereal glassine of basis weight 46 to 51 g/m² (28.5 to 31.5 lb/3000 ft²).

8. Sampling

8.1 Select a portion of the wax that is representative of the whole sample. The amount required will depend on the size of the waxing device used.

9. Standardization of Apparatus

9.1 Turn the blocking plate on with all sponge rubber strips and metal blocks in position. Allow sufficient time (3 h minimum) for the plate to reach an equilibrium temperature condition.

9.2 Calibrate a 30-gauge “test” thermocouple as follows: Heat a beaker of water to about 43.3°C (110°F) and measure its temperature with a temperature measuring device which is accurate to 0.3°C (0.5°F). Insert the “test” thermocouple in the water and measure the temperature with a manual potentiometer which is accurate to at least ±0.5°C (±1°F). A portable precision type potentiometer or a type K potentiometer, both of which are accurate to at least 0.5°F (0.3°C) in this temperature range, is preferred.

9.3 Lay the calibrated “test” thermocouple across the width of the plate with its junction directly over one of the imbedded thermocouples. Be sure that one of the sponge rubber strips covers the junction completely. Replace the weights on the rubber strips. After 3 to 4 min, note the temperature readings on the hand potentiometer and the corresponding point on the recorder. If the reading of the test thermocouple plus its calibration factor is more than 0.5°C (1°F) from that of the recorder reading, check the accuracy of the recorder separately.

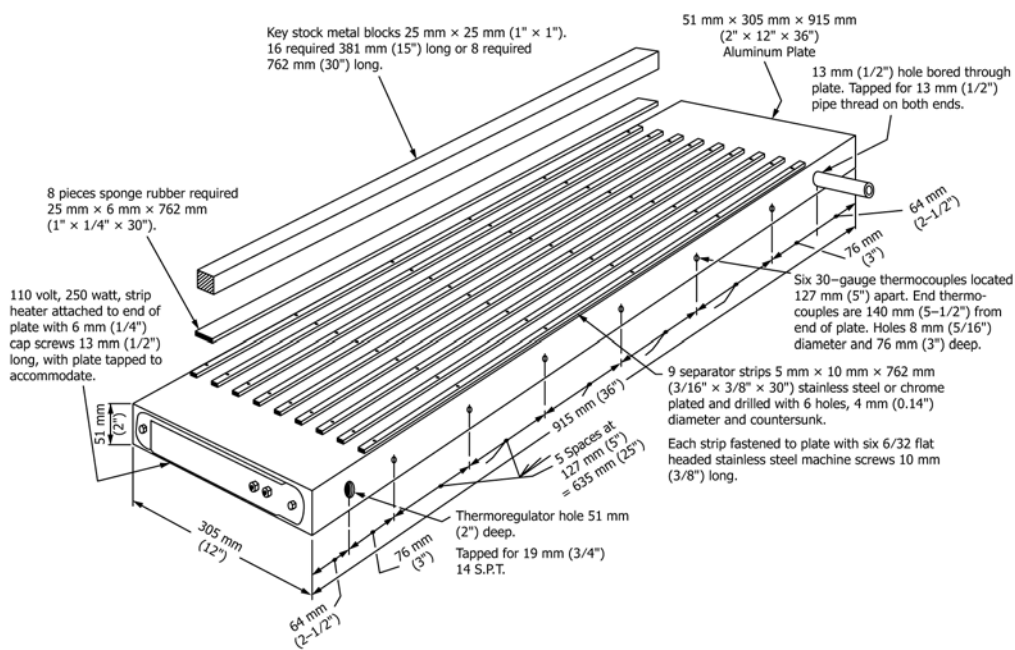

FIG. 1 Type A Blocking Plate