

FINAL
DRAFT

INTERNATIONAL
STANDARD

ISO/FDIS
22848

ISO/TC 156

Secretariat: SAC

Voting begins on:
2020-11-17

Voting terminates on:
2021-01-12

**Corrosion of metals and alloys —
Test method for measuring the
stress corrosion crack growth rate
of steels and alloys under static-load
conditions in high-temperature water**

iTeh STANDARD PREVIEW
(standards.iteh.ai)

[ISO/FDIS 22848](#)

<https://standards.iteh.ai/catalog/standards/sist/4e02f88a-0378-4c78-ad28-25139f25abc1/iso-fdis-22848>

RECIPIENTS OF THIS DRAFT ARE INVITED TO SUBMIT, WITH THEIR COMMENTS, NOTIFICATION OF ANY RELEVANT PATENT RIGHTS OF WHICH THEY ARE AWARE AND TO PROVIDE SUPPORTING DOCUMENTATION.

IN ADDITION TO THEIR EVALUATION AS BEING ACCEPTABLE FOR INDUSTRIAL, TECHNOLOGICAL, COMMERCIAL AND USER PURPOSES, DRAFT INTERNATIONAL STANDARDS MAY ON OCCASION HAVE TO BE CONSIDERED IN THE LIGHT OF THEIR POTENTIAL TO BECOME STANDARDS TO WHICH REFERENCE MAY BE MADE IN NATIONAL REGULATIONS.



Reference number
ISO/FDIS 22848:2020(E)

© ISO 2020

iTeh STANDARD PREVIEW
(standards.iteh.ai)

[ISO/FDIS 22848](https://standards.iteh.ai/catalog/standards/sist/4e02f88a-0378-4c78-ad28-25139f25abc1/iso-fdis-22848)

<https://standards.iteh.ai/catalog/standards/sist/4e02f88a-0378-4c78-ad28-25139f25abc1/iso-fdis-22848>



COPYRIGHT PROTECTED DOCUMENT

© ISO 2020

All rights reserved. Unless otherwise specified, or required in the context of its implementation, no part of this publication may be reproduced or utilized otherwise in any form or by any means, electronic or mechanical, including photocopying, or posting on the internet or an intranet, without prior written permission. Permission can be requested from either ISO at the address below or ISO's member body in the country of the requester.

ISO copyright office
CP 401 • Ch. de Blandonnet 8
CH-1214 Vernier, Geneva
Phone: +41 22 749 01 11
Email: copyright@iso.org
Website: www.iso.org

Published in Switzerland

Contents

Page

Foreword	iv
1 Scope	1
2 Normative references	1
3 Terms and definitions	1
4 Principle of test	2
5 Specimen	3
5.1 Specimen orientation.....	3
5.2 Specimen geometry.....	3
5.3 Specimen finish.....	4
5.4 Specimen size requirement.....	4
5.5 Specimen dimensional measurement.....	5
5.6 Stress intensity factor, K_I	5
6 Test equipment	5
7 Crack length measurement by potential drop method	6
8 Corrosion potential measurement	7
8.1 General.....	7
8.2 Measurement method.....	7
9 Test procedure	7
9.1 General.....	7
9.2 Installation in autoclave.....	8
9.3 Adjustment of test environment.....	9
9.4 Loading.....	9
9.4.1 General.....	9
9.4.2 Fatigue pre-cracking.....	9
9.4.3 SCC transitioning.....	9
9.4.4 Static loading.....	11
10 Evaluation of test results	11
11 Test report	14
Annex A (informative) CDCB specimen geometry and stress intensity factor calculation	16
Annex B (informative) Equipment for SCC growth testing	19
Annex C (informative) Water chemistry and monitoring items in simulated BWR and PWR environments	22
Annex D (informative) Approach to determine crack growth rate	24
Bibliography	25

Foreword

ISO (the International Organization for Standardization) is a worldwide federation of national standards bodies (ISO member bodies). The work of preparing International Standards is normally carried out through ISO technical committees. Each member body interested in a subject for which a technical committee has been established has the right to be represented on that committee. International organizations, governmental and non-governmental, in liaison with ISO, also take part in the work. ISO collaborates closely with the International Electrotechnical Commission (IEC) on all matters of electrotechnical standardization.

The procedures used to develop this document and those intended for its further maintenance are described in the ISO/IEC Directives, Part 1. In particular, the different approval criteria needed for the different types of ISO documents should be noted. This document was drafted in accordance with the editorial rules of the ISO/IEC Directives, Part 2 (see www.iso.org/directives).

Attention is drawn to the possibility that some of the elements of this document may be the subject of patent rights. ISO shall not be held responsible for identifying any or all such patent rights. Details of any patent rights identified during the development of the document will be in the Introduction and/or on the ISO list of patent declarations received (see www.iso.org/patents).

Any trade name used in this document is information given for the convenience of users and does not constitute an endorsement.

For an explanation of the voluntary nature of standards, the meaning of ISO specific terms and expressions related to conformity assessment, as well as information about ISO's adherence to the World Trade Organization (WTO) principles in the Technical Barriers to Trade (TBT) see www.iso.org/iso/foreword.html.

This document was prepared by Technical Committee ISO/TC 156, *Corrosion of metals and alloys*

Any feedback or questions on this document should be directed to the user's national standards body. A complete listing of these bodies can be found at www.iso.org/members.html.

Corrosion of metals and alloys — Test method for measuring the stress corrosion crack growth rate of steels and alloys under static-load conditions in high-temperature water

1 Scope

This document specifies a test method for determining the stress corrosion crack (SCC) growth rate of steels and alloys under static-load conditions in high-temperature water, such as the simulated water environment of light water reactors. The crack length of the specimen is monitored by a potential drop method (PDM) during the test in an autoclave.

The test method is applicable to stainless steels, nickel base alloys, low alloy steels, carbon steels and other alloys.

2 Normative references

The following documents are referred to in the text in such a way that some or all of their content constitutes requirements of this document. For dated references, only the edition cited applies. For undated references, the latest edition of the referenced document (including any amendments) applies.

ISO 7539-6, *Corrosion of metals and alloys — Stress corrosion testing — Part 6: Preparation and use of precracked specimens for tests under constant load or constant displacement*

<https://standards.iteh.ai/catalog/standards/sist/4e02f88a-0378-4c78-ad28-25139f25abc1/iso-fdis-22848>

3 Terms and definitions

For the purposes of this document, the terms and definitions given in ISO 7539-6 and the following apply.

ISO and IEC maintain terminological databases for use in standardization at the following addresses:

- ISO Online browsing platform: available at <https://www.iso.org/obp>
- IEC Electropedia: available at <http://www.electropedia.org/>

3.1

potential drop method

PDM

non-destructive method for measuring a crack length based on the change in the electric potential as a crack propagates in the presence of an applied DC or AC current

3.2

stress corrosion crack transitionning

SCC transitionning

use of cyclic loading at low frequency and with increasing hold time at maximum load in the test environment to promote a transition in the fracture surface morphology from a transgranular (TG) fatigue pre-crack to SCC, typically intergranular (IG) or interdendritic (ID) morphology for austenitic alloys

3.3

crack-tip re-activation loading

use of loading cycles to re-activate the tip of crack when crack retardation is observed under a static loading

**3.4
initial crack length**

a_0
<compact tension (CT) specimen> distance from the load line to the initial crack tip

Note 1 to entry: It can refer to the machined notch tip or the air fatigue pre-crack front in the specimen.

Note 2 to entry: For other fracture mechanics geometries, refer to ISO 7539-6. The crack length (a) is often expressed as a proportion of the distance from the load-line to the end of the specimen (W): a/W .

**3.5
final crack length**

a_f
distance from the load line to the final crack front at the end of the stress corrosion crack growth test, where the crack length is measured on the fracture surface of the specimen

**3.6
flow stress at test temperature**

σ_{flowT}
algebraic average of the yield stress (σ_{yT}) and the ultimate tensile strength (σ_{uT}) at the test temperature:

$$\sigma_{\text{flowT}} = (\sigma_{\text{yT}} + \sigma_{\text{uT}})/2$$

**3.7
crack engagement**

specimen thickness B where the stress corrosion crack has advanced

Note 1 to entry: It is expressed as a percentage.

**3.8
average crack extension**

A_1
average crack extension across the specimen thickness using a crack growth area or many equally spaced measurements of crack length (equally divided method)

**3.9
average crack extension in crack engagement area**

A_2
average crack extension based on the fraction of the specimen thickness where the stress corrosion crack has occurred

**3.10
minimum crack extension**

A_{min}
minimum extension of the stress corrosion crack in the specimen

**3.11
maximum crack extension**

A_{max}
maximum extension of the stress corrosion crack in the specimen

4 Principle of test

Stress corrosion cracking is a phenomenon in which a crack grows in an environment when stress is applied to a susceptible material. Thus, stress corrosion cracking is affected by three general factors: the material, stress and environment. The SCC growth rate is affected by the stress intensity factor, K_I . The SCC growth rate, da/dt , is defined as the time derivative of the crack length. While there is often no clear distinction between static loading and some very slowly increasing monotonically or cyclic loading, the primary interest in most SCC growth testing is the behaviour under static loading. By

applying a static load to a specimen with a crack at a known K_I and continuously measuring the crack length (a) using the PDM, the crack growth rate (da/dt) can be continuously obtained. Often the best insight into the effects of environment and temperature are obtained by making periodic changes while continuously measuring the SCC growth response.

This document specifies the preparation of specimens, the control of the testing environment, the method of transitioning from fatigue crack to SCC, and the determination of the growth rate of a crack using fracture mechanics specimens in high-temperature water environments, with an emphasis on light water reactors.

Although the minimum requirements and basic procedures of SCC growth rate testing in high-temperature water are summarized in this document, it should be noted that there are complex interdependencies of many influential parameters on stress corrosion cracking phenomena, and subtle variations in test conditions can have a major impact on the reproducibility and credibility of the data. Extensive efforts to obtain high-quality SCC growth rate data have been undertaken over the last four decades and many key issues must be understood and implemented (see References [1] to [3]). For example, reliable SCC transitioning prior to static loading is an essential element, and specific procedures have been developed to help achieve well-behaved response.

5 Specimen

5.1 Specimen orientation

The specimen orientation in the test material is designed in accordance with ISO 7539-6.

The relative orientation of the crack plane and growth direction in the test material shall be specified in relation to the product form (such as plate rolling direction or pipe longitudinal direction) and, if applicable, also specified in relation to the weld direction and additional cold work (e.g. for rolling or forging). When the specimen is taken in or near a weld, the location of the crack plane of the specimen in relation to the weld fusion line shall be provided because of a very pronounced effect on SCC behaviour is expected when the crack in the specimen propagates in the heat affected zone or weld metal of the test material, and the properties can vary from the weld root to the weld crown.

5.2 Specimen geometry

Many specimen geometries have been used for crack growth testing (see ISO 7539-6). The most common specimen is a compact tension (CT) specimen with a side-groove design, shown in [Figure 1](#). The specimen thickness, B , is usually between $12,5 \times 10^{-3}$ m and $25,4 \times 10^{-3}$ m. Smaller or larger specimens are sometimes used but shall be justified from K -size criteria (see [5.4](#)). The specimen width, W , is typically two times the specimen thickness (B).

Side grooves on both sides of the specimen are recommended to help maintain in-plane crack growth, but are not obligatory. The depth of each side groove is typically 5 % of B , and they are typically hemispherical.

The more complex contoured double cantilever beam (CDCB) specimen is also used because the stress intensity factor is practically considered constant over a certain range of crack lengths under constant-load conditions. However, note that the criteria for a CT specimen given in [5.4](#) is not applicable to a CDCB specimen. Details for a CDCB specimen are given in [Annex A](#).

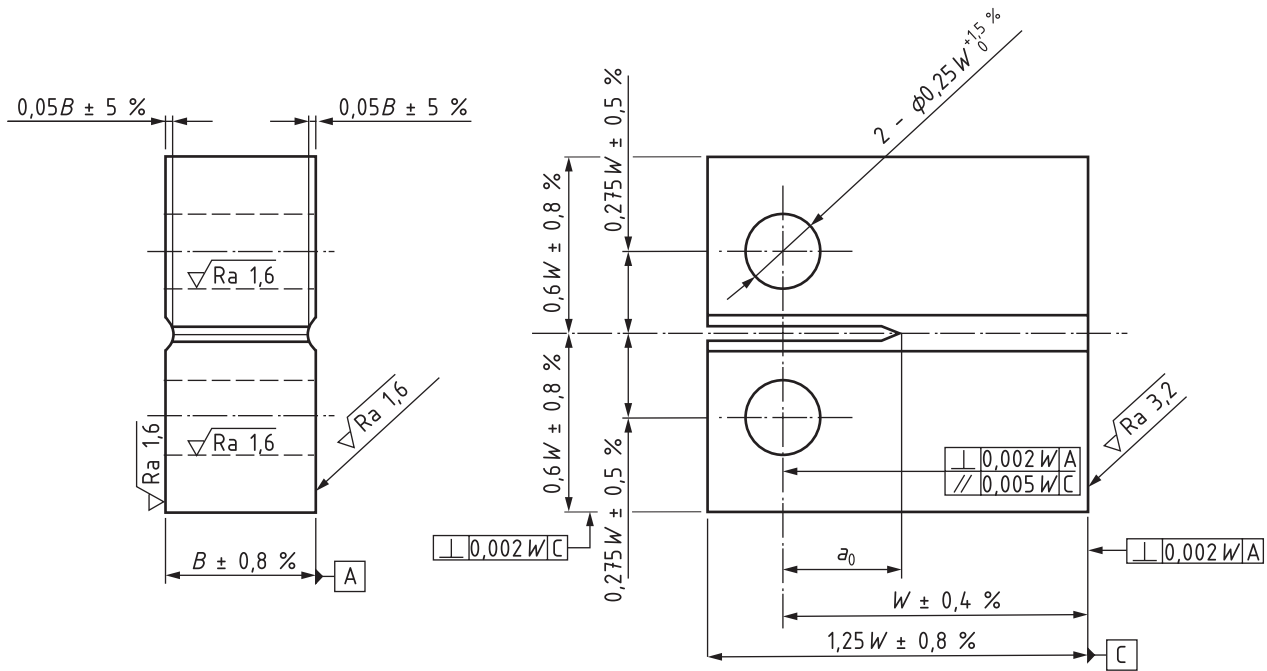

Figure 1 — Typical dimensions and tolerances of a CT specimen

iTeh STANDARD PREVIEW
(standards.iteh.ai)

5.3 Specimen finish

The surface of the specimen is mechanically finished to remove the working layers and residual stresses, and the recommended surface roughness is given in Figure 1. Surface condition generally has the largest effect on the corrosion potential, which in turn can affect SCC growth rates.

5.4 Specimen size requirement

Specimen size shall be chosen based on the mechanical properties of the test material and K_I value used in testing. There is no well-established K -size criterion for SCC growth testing, but the following formula is commonly used and considered conservative (except for low work-hardening materials, such as highly cold worked or irradiated materials). When load is applied to a sharp crack, some plasticity occurs, and linear elastic fracture mechanics (LEFM) requires that the plasticity (e.g. plastic zone size) be limited to small scale yielding. Different values of β are specified in various standards, for example, based on the magnitude of cyclic loading, which produces a smaller, fatigue hardened plastic zone. There are some studies on specimen size effects in SCC testing, including irradiated materials. Some publications are helpful for determining specimen size (see References [4] to [7]).

$$B_e, W - a > \beta \left(K_I / \sigma_{yT} \right)^2 \tag{1}$$

where

B_e is the effective thickness of the specimen, $(B \cdot B_N)^{1/2}$, where B_N is the specimen thickness at the base of the side grooves; if no side grooves are used, $B_e = B$ (in m);

W is the specimen width (in m);

a is the crack length (in m);

β is the factor related to the extent of plasticity considered acceptable ($\beta = 2,5$ is sometimes used);

K_I is the stress intensity factor (in MPa $\sqrt{\text{m}}$);

σ_{yT} is the yield stress at the test temperature (in MPa).

However, in [Formula \(1\)](#), when $\sigma_{uT} / \sigma_{yT} > 1,3$ is satisfied, $\sigma_{\text{flow}T}$ can be used instead of σ_{yT} .

5.5 Specimen dimensional measurement

The dimensions of the specimen are measured and confirmed to be within the fabrication tolerance shown in [Figure 1](#).

5.6 Stress intensity factor, K_I

The stress intensity factor, K_I , for a CT specimen is defined as shown in [Formula \(2\)](#):

$$K_I = \frac{P}{B_e \sqrt{W}} \frac{(2+\alpha)}{(1-\alpha)^{3/2}} (0,886 + 4,64\alpha - 13,32\alpha^2 + 14,72\alpha^3 - 5,6\alpha^4) \quad (2)$$

where

K_I is the stress intensity factor (in MPa $\sqrt{\text{m}}$);

P is the load (in MN);

α a/W .

NOTE The accuracy of [Formula \(2\)](#) is $\pm 0,5\%$ over the range $0,2 \leq \alpha \leq 1,0$. K_I can also be obtained by finite element analysis.

<https://standards.iteh.ai/catalog/standards/sist/4e02f88a-0378-4c78-ad28-25139f25abc1/iso-fdis-22848>

6 Test equipment

A typical test system consists of a high-temperature, high-pressure autoclave with a loading machine and a water circulation system that flows a simulated light water reactor environment through the autoclave. While the volume and pressure of the autoclave depends on the size of the specimen and target test temperature, a smaller volume is generally preferable to achieve better control of the test parameters. An ion exchanger shall be incorporated in the circulation loop to remove ionic impurities generated by corrosion of the test specimen or system materials. If dosing species (such as pH control additives or boric acid) are added to the test environment for a simulated pressurized water reactor (PWR) environment, the demineralizer shall be equilibrated to the desired chemistry (e.g. B, Li). A once-through system can also be used to maintain the environment chemistry, although a circulating system generally provides a better control of the water chemistry in the autoclave because of the higher refresh rate. For relatively pure boiling water reactor (BWR) environments, a recirculating system is necessary, and if impurities are desired (e.g. 30 $\mu\text{g}/\text{l}$ sulfate), they are ideally continuously added to the water flowing into the autoclave, with appropriate continuous monitoring of ionic species or solution conductivity, and clean-up of return water from the autoclave.

Control of dissolved gases, especially oxygen or hydrogen, in the test environment is usually accomplished by continuous bubbling in the reservoir, which ideally has a much smaller diameter than height, and generally should be of limited volume (e.g. < 10 l). The solubility of oxygen at standard temperature and pressure (STP) is about 43 mg/l (and varies with temperature), and the solubility of hydrogen is about 1,6 mg/l (and varies less near room temperature). Conditions (dissolved gases, autoclave volume, refresh rate and system materials) shall be chosen to ensure that the outlet gas concentration is a high fraction of the inlet (e.g. $> 80\%$); this is especially an issue for dissolved oxygen concentrations below about 100 $\mu\text{g}/\text{l}$, and a bigger issue if hydrogen is also present.

Test stability is important, and load, temperature, water purity and dissolved gas concentration shall be kept constant during a given test segment. Stability of room temperature is also important, because it can affect dissolved gas concentration, water purity and precision instrumentation used to control temperature and measure crack length.

The test equipment includes devices to continuously monitor the crack length, temperature, water quality parameters such as solution conductivity and dissolved gases, and corrosion potential. The corrosion potential measurement is less important in a simulated PWR environment (with dissolved hydrogen and no dissolved oxygen) than in a simulated BWR environment with dissolved oxygen. Nevertheless, measuring corrosion potential is recommended to ensure that the corrosion potential has reached an appropriate value prior to the testing and to detect changes in water chemistry.

Some examples of test equipment in BWR and PWR water environments are provided in [Annex B](#), together with a typical schematic diagram of the water loop. More detailed water chemistry and monitoring items are provided in [Annex C](#) and Reference [3].

7 Crack length measurement by potential drop method

7.1.1 Both direct current (DC) and alternating current (AC) PDMs have been used. DC is most widely used because it is less susceptible to electrical noise, and easier and less expensive to implement.

7.1.2 The PDM has many applications in the measurement of the fatigue crack growth rate and extensive guidelines exist for measuring fatigue crack growth rates (see References [8] and [9]). While the majority of the practices described in the standards are valid when applied to SCC growth testing, there are additional factors specific to SCC growth tests in high-temperature water environments.

7.1.3 For high-quality PDM measurements using reversed DC current, a digital voltmeter capable of integration over ≥ 1 power line cycle is essential, and many \pm current readings shall be averaged (typically 100 to 5 000, depending on the crack growth rate) to achieve good crack length resolution. If PDM readings are taken during any unloading and reloading cycles, some bias downward in crack length may be observed from crack closure.

7.1.4 The wires inside the high-temperature autoclave shall be insulated. Below about 300 °C, polytetrafluoroethylene (PTFE) (standard tubing, or heat-shrinkable tubing) is commonly used. At higher temperatures, pieces of partially stabilized zirconia (e.g. 3 % mass fraction MgO) are commonly used.

7.1.5 The electrical resistivity changes with time at temperature in many nickel base alloys, and can create the false impression of crack advance when using PDM measurements. Higher temperature or cold work produces a faster approach to saturation. The need for compensation for resistivity changes depends on both the alloy and heat as well as the crack growth rate being measured. For example, at 10^{-8} m/s, a resistivity change even early in the test would not affect the subsequent measured growth rate. But below 10^{-11} m/s, small changes can affect the measured growth rate. A “reference potential” shall be measured on the same material and condition as the specimen because the alloy, heat, cold work and prior temperature exposure affect the resistivity change versus time. The reference potential can be measured on a separate rod or coupon, or on the back-face of the specimen. When the back-face potential is used, the change in reference potential as the crack grows should be considered. The resistivity change with time for stainless and ferritic steels is much smaller than nickel base alloys, and compensation is rarely done. Historically, a reference potential measurement has been used to compensate for temperature or DC current fluctuations, but eliminating these fluctuations is much more effective than compensating for them.

7.1.6 The temperature fluctuation in the autoclave has a big effect on the accuracy of the crack length measurement by the PDM. It is necessary to suppress the change of temperature as much as possible.

7.1.7 Uneven crack advance is more common in SCC growth tests in high-temperature water than in fatigue tests, and it significantly affects the accuracy of all forms of crack length measurement, which

are strongly biased by the regions of least crack advance. The (commonly IG) crack morphology, crack branching and less planar crack growth in SCC versus fatigue growth tests can produce current shorting in the wake of the crack, causing a significant underestimation of crack size. In such circumstances, where a large discrepancy is observed between the PDM and fractography measurements, a linear post-test correction of crack depth, crack growth rate and K is recommended because it is not known how or when the problems developed during the test.

The following issues should be addressed to reduce the noise of the PDM signal: wire routing of the PDM cables, electrical insulation between the specimen(s) and the loading clevis, position and stability of the current lead attachment.

The current applied to the specimen during PDM measurements can affect the measurement of corrosion potential, although the effect is minimized by using continuous PTFE insulation of the current leads from outside the autoclave to the specimen. It is recommended that the current applied to the specimen be turned off for several seconds before corrosion potential measurements.

8 Corrosion potential measurement

8.1 General

Corrosion potential (E_{corr}) shall be measured in simulated BWR environment tests. It should be measured in simulated PWR environment tests.

8.2 Measurement method

A high-input-impedance ($\geq 10^{14} \Omega$ is recommended) electrometer is used to measure the potential between the CT specimen and a reference electrode.

Several types of reference electrodes are commonly used:

- Ag/AgCl/Cl⁻ electrodes (internal type and pressure balanced external type);
- Membrane, metal/metal oxide electrodes (Fe/Fe₃O₄, Cu/Cu₂O, etc.).

Also, to ensure the accuracy of the potential measurements, including a platinum electrode is recommended because its potential is precisely known in hydrogen-only environments, and is quite well defined in oxygen-only environments.

9 Test procedure

9.1 General

A flow chart of SCC growth testing is shown in [Figure 2](#). After preparing the specimen and getting ready for the PDM measurement and E_{corr} measurement (leads, reference electrode, etc.), the crack growth test is performed using the following procedures.

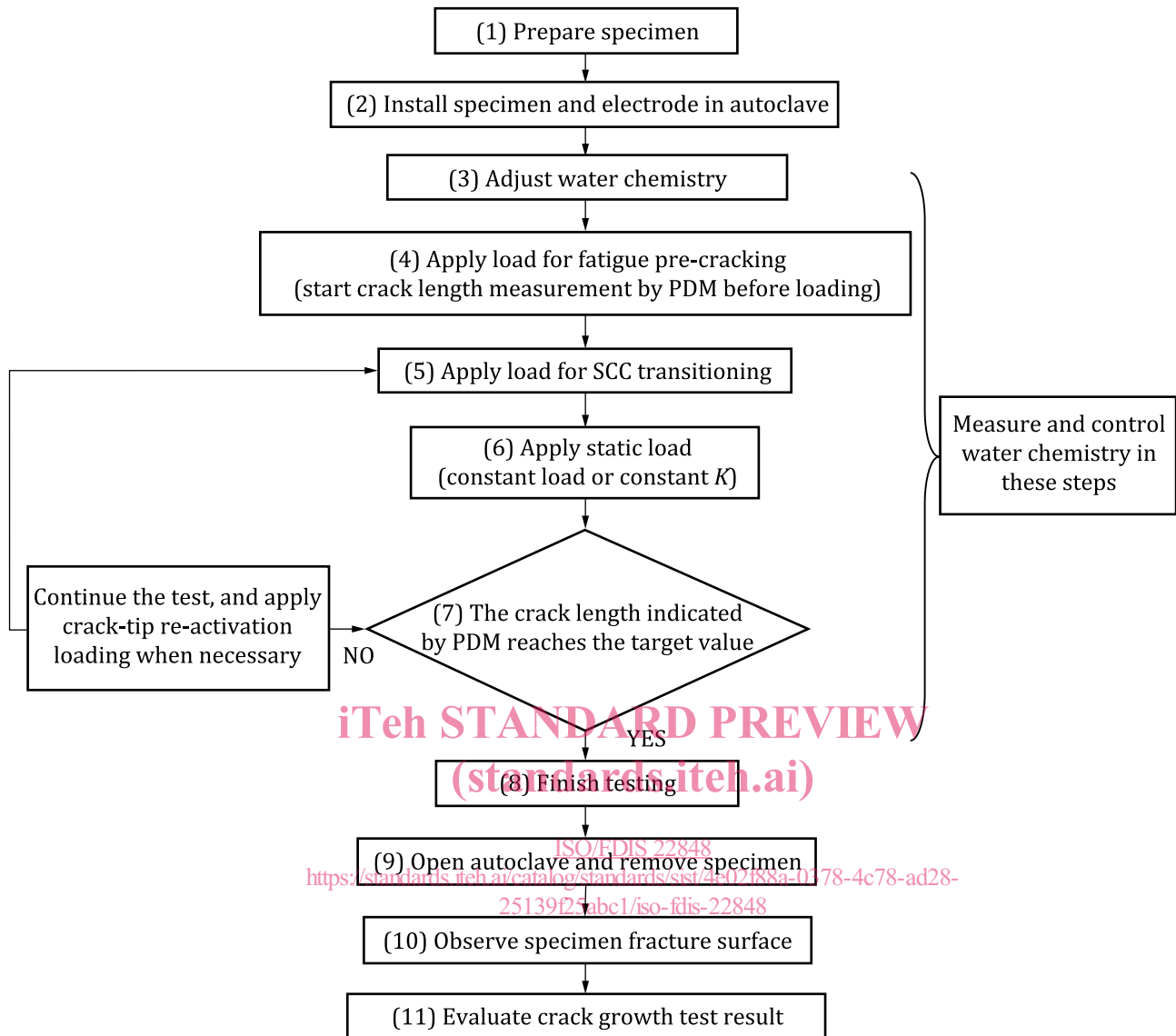

Figure 2 — A flow chart of SCC growth test in simulated light water reactor environment

9.2 Installation in autoclave

9.2.1 After cleaning, the specimen is installed in the loading clevises, and leads for PDM are attached: one set for the DC or AC current to the specimen and one for measuring the electrical potential drop as the crack grows. A third set is needed if reference potentials are used. The loading linkage shall be insulated at least at one location to eliminate an alternate current path. The current shall flow only through the specimen (see 7.1.4). A ground isolated power supply is also essential to prevent “ground loops” (current that could flow through the linkage and autoclave materials to ground, thereby creating an alternative path to its flow through the specimen).

9.2.2 A reference electrode for the E_{corr} measurement is installed in the autoclave near the specimen. Also, it is recommended that a platinum electrode is installed near the reference electrode. The wiring and inter-connections (which are often a limiting factor) shall be carefully designed to maintain a high impedance between the two leads.