



Designation: ~~D2463-10~~ Designation: D2463 – 10a

Standard Test Method for Drop Impact Resistance of Blow-Molded Thermoplastic Containers¹

This standard is issued under the fixed designation D2463; the number immediately following the designation indicates the year of original adoption or, in the case of revision, the year of last revision. A number in parentheses indicates the year of last reapproval. A superscript epsilon (ϵ) indicates an editorial change since the last revision or reapproval.

1. Scope

1.1 This test method provides measures of the drop impact resistance of blow-molded thermoplastic containers as a summation of the effects of material, manufacturing conditions, container design, and perhaps other factors.

1.2 Three procedures are provided as follows:

1.2.1 *Procedure A, Static Drop Height Method*—This procedure is particularly useful for quality control since it is quick.

1.2.2 *Procedure B, Bruceton Staircase Method*—This procedure is used to determine the mean failure height and the standard deviation of the distribution.

1.3 The values stated in SI units are to be regarded as standard. The inch-pound units given in parentheses are for information only.

NOTE 1—There is no known ISO equivalent to this standard.

1.4 *This standard does not purport to address all of the safety concerns, if any, associated with its use. It is the responsibility of the user of this standard to establish appropriate safety and health practices and determine the applicability of regulatory limitations prior to use.*

2. Referenced Documents

2.1 *ASTM Standards:*²

B177 [Guide for Engineering Chromium Electroplating](#)

E691 [Practice for Conducting an Interlaboratory Study to Determine the Precision of a Test Method](#)

iTeh Standards

(<https://standards.itih.ai>)
Document Preview

[ASTM D2463-10a](#)

<https://standards.itih.ai/catalog/standards/sist/cff09f23-d676-4c5a-9d8f-5555bead5b31/astm-d2463-10a>

¹ This test method is under the jurisdiction of ASTM Committee D20 on Plastics and is the direct responsibility of Subcommittee D20.19 on Film and Sheeting. Current edition approved Feb. 1, 2010. Published February 2010. Originally approved in 1965. Last previous edition approved in 2005 as D2463-95(2005). DOI: 10.1520/D2463-10 on Molded and Extruded Products.

Current edition approved May 15, 2010. Published June 2010. Originally approved in 1965. Last previous edition approved in 2010 as D2463-10. DOI: 10.1520/D2463-10A.

² For referenced ASTM standards, visit the ASTM website, www.astm.org, or contact ASTM Customer Service at service@astm.org. For *Annual Book of ASTM Standards* volume information, refer to the standard's Document Summary page on the ASTM website.

2.2 *Society of Plastics Industry Standard:*
PBI-4 Test for Drop Impact Resistance of Plastic Bottles³

3. Terminology

3.1 Definitions:

3.1.1 *failure*—any rupture visible to an observer with the unaided eye and normal eyesight is considered a failure. Any evidence of contained liquid on the outside of the container through any aperture other than the molded opening is also a failure. Container should be squeezed gently after impact to determine any pinhole type failures. If a cap pops off during impact, consider that sample as a NO TEST and replace the sample with another container.

4. Summary of Test Method

4.1 The drop impact resistance is determined by dropping conditioned blow-molded containers filled with water from a platform onto a prescribed surface. Data developed with a water-filled container are not always representative of what might be expected with a carbonated liquid, an aerosol pack, a product of high specific gravity, or a powder of low bulk density.

4.1.1 *Procedure A* consists of dropping at least 20 containers from a fixed height and reporting the percent failures.

4.1.2 *Procedure B* consists of dropping at least 20 test containers from varying heights above and below the mean failure height of the set. A mean failure height and standard deviation are then calculated from the data.

5. Significance and Use

5.1 These procedures provide measures of the drop impact resistance of the group or lot of blown containers from which the test specimens were selected.

5.2 It is acceptable to use these procedures for routine inspection purposes.

5.3 These procedures will evaluate the effect of construction, materials, and processing conditions on the impact resistance of the blown containers.

5.4 Before proceeding with this test method, reference the specification of the material being tested. Any test specimen preparation, conditioning, dimensions, or testing parameters, or combination thereof, covered in the materials specification shall take precedence over those mentioned in this test method. If there are no material specifications, then the default conditions apply.

6. Apparatus

6.1 *Drop Testing Machine* (see Fig. 1), having the following features:

6.1.1 A platform (see Fig. 2) upon which to set the test specimens, which can be raised or lowered either manually or by means of an electric motor.

6.1.2 The platform shall be adjustable to make it suitable for being leveled but shall also be stable so that it will not tilt under the weight of the test specimen.

6.1.3 The platform shall be spring-loaded so that upon release it will move rapidly out of the path of the test specimen and will not interfere with its fall.

6.1.4 A manually or electrically operated platform release mechanism that will hold the platform securely when being loaded but will release the platform instantaneously and will not interfere with its path of travel.

6.2 A surface on which the containers are dropped consisting of a flat hot-rolled steel plate, or equivalent, with minimum dimensions of 1000 mm by 1000 mm by 13 mm (36 in. by 36 in. by ½ in.) having an unpolished chrome-plated surface, plated in accordance with Practice B177, and securely attached to an industrial concrete surface or floor, so that the line of drop of the containers is perpendicular to the chrome-plated surface.

6.3 A means of measuring the height of the platform above the impact surface.

6.3.1 If a more stringent impact test is desired, securely fasten a positioning jig capable of holding a test container at the proper angle for a 45° angle impact to the platform. When such a jig is used, the drop height must be measured from the lowest part of the container. Precision data are not available for testing under these conditions.

7. Test Specimens

7.1 A minimum of 20 containers shall be selected so they are representative of the lot being tested for any one of the test procedures. These shall be fitted with suitable closures.

8. Preparation of Apparatus

8.1 Periodically, or before each test series, check the platform of the drop impact machine, and adjust it if necessary, to ensure that the specimen will strike the impact area squarely on the desired surface. If this is necessary, use the following procedure:

8.1.1 Move the platform to the approximate mean failure height of the containers to be tested with a specimen on the platform in the desired position.

³ Available from the Society of the Plastics Industry, Inc., 1295 K Street, N.W., Washington, DC 20005.

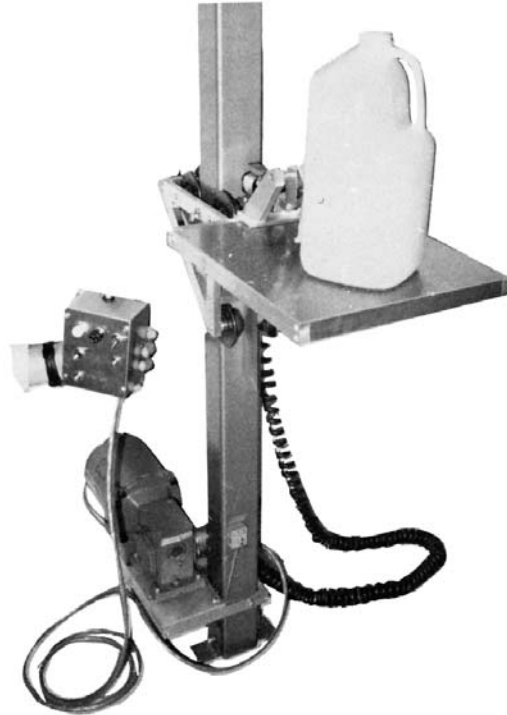

FIG. 1 Apparatus for Dropping Containers

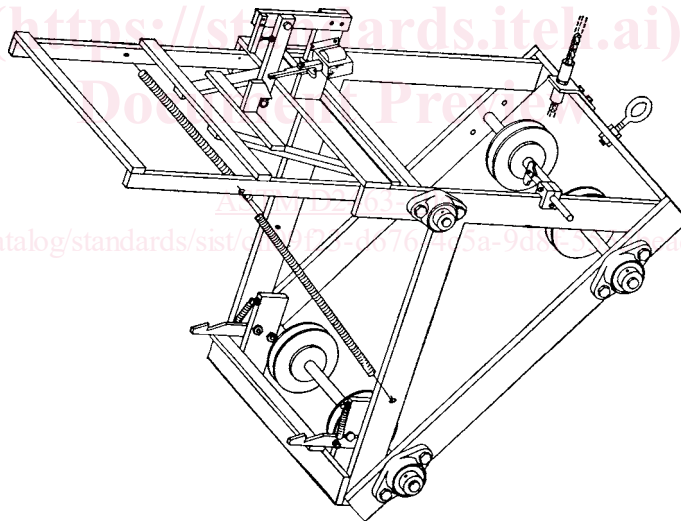

FIG. 2 Platform Assembly

8.1.2 Release the platform allowing the specimen to fall onto the impact surface.

8.1.3 Take a snapshot picture of the container just before it strikes the impact surface. Two photographs shall be taken at right angles to each other to ascertain that the container impacts as desired—front to back and side to side. The position of the container relative to the impact surface as it appears in the photographs will indicate whether or not adjustments in the platform are necessary.

8.1.3.1 When photographs are taken, set up the camera approximately 300 mm (12 in.) above and 1800 mm (72 in.) from the impact area.

NOTE 2—A camera from which prints are immediately available is most suitable.

8.1.4 Make adjustments in the platform and repeat the procedure as specified in 8.1.3 as necessary.

9. Conditioning

9.1 Fill containers with tap water to their nominal fill capacity and condition them uncapped for 24 h at $23 \pm 2^\circ\text{C}$ ($73 \pm 3.6^\circ\text{F}$).

9.2 If the test is intended for immediate quality control, fill the containers with room temperature water and test at that