



Designation: D6640 – 01 (Reapproved 2010)

Standard Practice for Collection and Handling of Soils Obtained in Core Barrel Samplers for Environmental Investigations¹

This standard is issued under the fixed designation D6640; the number immediately following the designation indicates the year of original adoption or, in the case of revision, the year of last revision. A number in parentheses indicates the year of last reapproval. A superscript epsilon (ϵ) indicates an editorial change since the last revision or reapproval.

1. Scope

1.1 This practice covers procedures for obtaining soils from core barrel samplers for chemical and physical analysis, with an emphasis on the collection and handling procedures that maintain the representativeness of the chemical contaminants of concern. Core barrel samplers are initially empty (hollow) until they are pushed into the ground to collect and retrieve a cylindrical soil sample with minimal disturbance. The selection of equipment and the sample handling procedures are dependent on the soil properties, the depth of sampling, and the general properties of the chemical contaminants of concern, that is, volatile organic compounds, semi-volatile organic compounds, and inorganic constituents. The sampling procedures described are designed to maintain representative concentrations of the contaminants regardless of their physical state(s), that is, solid, liquid or gas.

1.2 Four general types of core barrel samplers are discussed in this practice: split-barrel, ring-lined barrel, thin-walled tube, and solid-barrel samplers.

1.3 This document does not cover all the core barrel devices that are available for the collection of soil samples.

1.4 The procedures described may or may not be applicable to handling of samples for assessing certain geotechnical properties, for example, soil porosity.

NOTE 1—Prior to commencement of any intrusive exploration, the site should be checked for underground utilities.

1.5 *This standard does not purport to address all of the safety concerns, if any, associated with its use. It is the responsibility of the user of this standard to establish appropriate safety and health practices and determine the applicability of regulatory limitations prior to use.*

¹ This practice is under the jurisdiction of ASTM Committee D34 on Waste Management and is the direct responsibility of Subcommittee D34.01.03 on Sampling Equipment.

Current edition approved May 1, 2010. Published June 2010. Originally approved in 2001. Last previous edition approved in 2005 as D6640-01 (2005). DOI: 10.1520/D6640-01R10.

2. Referenced Documents

2.1 *ASTM Standards*:²

- D653 Terminology Relating to Soil, Rock, and Contained Fluids
- D1586 Test Method for Penetration Test (SPT) and Split-Barrel Sampling of Soils
- D1587 Practice for Thin-Walled Tube Sampling of Soils for Geotechnical Purposes
- D3550 Practice for Thick Wall, Ring-Lined, Split Barrel, Drive Sampling of Soils
- D3694 Practices for Preparation of Sample Containers and for Preservation of Organic Constituents
- D4547 Guide for Sampling Waste and Soils for Volatile Organic Compounds
- D4687 Guide for General Planning of Waste Sampling
- D4700 Guide for Soil Sampling from the Vadose Zone
- D5088 Practice for Decontamination of Field Equipment Used at Waste Sites
- D5784 Guide for Use of Hollow-Stem Augers for Geoenvironmental Exploration and the Installation of Subsurface Water-Quality Monitoring Devices
- D5792 Practice for Generation of Environmental Data Related to Waste Management Activities: Development of Data Quality Objectives
- D5875 Guide for Use of Cable-Tool Drilling and Sampling Methods for Geoenvironmental Exploration and Installation of Subsurface Water-Quality Monitoring Devices
- D5876 Guide for Use of Direct Rotary Wireline Casing Advancement Drilling Methods for Geoenvironmental Exploration and Installation of Subsurface Water-Quality Monitoring Devices
- D6051 Guide for Composite Sampling and Field Subsampling for Environmental Waste Management Activities
- D6151 Practice for Using Hollow-Stem Augers for Geotechnical Exploration and Soil Sampling

² For referenced ASTM standards, visit the ASTM website, www.astm.org, or contact ASTM Customer Service at service@astm.org. For *Annual Book of ASTM Standards* volume information, refer to the standard's Document Summary page on the ASTM website.

D6169 Guide for Selection of Soil and Rock Sampling Devices Used With Drill Rigs for Environmental Investigations

D6232 Guide for Selection of Sampling Equipment for Waste and Contaminated Media Data Collection Activities

D6282 Guide for Direct Push Soil Sampling for Environmental Site Characterizations (Withdrawn 2014)³

D6286 Guide for Selection of Drilling Methods for Environmental Site Characterization

3. Summary of Practice

3.1 Obtaining soil samples from the surface and subsurface for chemical and physical analysis often involves the advancement of a core barrel sampler into the ground. A core barrel sampler can be operated by hand or mechanically, and it may be of a closed or open design (D6282). Once the core barrel has been filled, the sampler is recovered from the bore hole and the soil sample is handled appropriately for the chemical constituents of concern.

3.2 This practice describes collection and handling procedures used with four types of core barrel samplers. The standards related to data quality objectives (D5792), equipment specifications (D6232, D6169 and D4700), their limitations and advantages (D6282), and the site-specific geological and hydrological data should be reviewed to determine the soil coring equipment that is best suited for a specific project.

4. Significance and Use

4.1 Often during environmental investigations, soils are analyzed after being collected from the surface, the vadose zone (D653) and sometimes from below the ground water table to identify and quantify the presence of a chemical contaminant. A contaminant is a substance that is typically hazardous and either is not normally present or that occurs naturally but is of an uncharacteristically high concentration (D4687). A three-dimensional spatial array of samples can often provide information as to the source and route(s) of migration of the contaminant. The resultant information is used to direct remedial and corrective actions or can be used for monitoring purposes. Obtaining a soil sample with a core barrel sampler involves driving this device into the ground and then retrieving it for sample processing. Several methods for advancing a core barrel are generally acceptable (e.g., D1586, D1587, D3550, D4700, D5784, D5875, D5876, D6151, D6282, and D6286). Drilling methods that use drilling fluids (liquids or air) should be avoided because they are more susceptible to cross-contamination (See Section 5.1.6).

5. Equipment Selection Criteria

5.1 Important criteria to consider when selecting a core barrel sampler for soil sampling are:

5.1.1 The materials that come into direct contact with the soil sample (barrel or barrel liner) should be compatible with the chemical or physical properties of the contaminant(s) of concern and the chemical properties of the soil. As a general

rule samples obtained for semi-volatile organic compound analysis can be obtained within a core barrel or core barrel liner that is composed of stainless steel, steel, or brass. When only inorganic constituents are of concern, a plastic core barrel liner would be more appropriate than the previously cited materials. All of these materials are suitable for volatile organic compounds as long as the contact time is minimized. Often all of the above samples (semi-volatile organic, inorganic, and volatile organic compounds) are obtained from a single soil core. In this situation, soils should be taken from the interior of the soil core to avoid potential interferences between the contaminants of concern and the surface of the core barrel that is in direct contact with the sample.

5.1.2 The design of the core barrel sampler should allow for easy access to the sampled substrate for all subsequent handling procedures.

5.1.3 Core barrel size requirements depend on the type and number of chemical constituents of concern. For example, more soil is needed for the collection of samples intended for semi-volatile organic compound analysis than for the analysis of volatile organic compounds or inorganic constituents or both. Typically, a 250-mL (8-oz) bottle is filled for the analysis of semi-volatile organic compounds, a 125-mL (4-oz) bottle for inorganic constituents, and only 5-g subsamples are taken for volatile organic compounds.

5.1.4 Suitability for soil type, that is, grain size, cohesion properties, and moisture content. For example, when sampling non-cohesive materials or when sampling below the water table, a core catcher (basket) should be used to limit the loss of sample and ground water during retrieval (D4700 and D6282).

5.1.5 The spreading of contamination between sampling depths should be minimized. Sealed hollow-barrel samplers (6.1.4) or cased bore holes and proper advancement techniques should be used to limit cross-contamination between sampling depths in the vadose zone. Although a cased bore hole does not guarantee that contamination will not be spread from one sampling depth to another, it lowers the possibility and eliminates the potential for bore hole collapse and side wall slough that can compromise the integrity of the samples removed from uncased bore holes. When there is standing ground water in the bore hole, a sealed sampler system should be used.

5.1.6 Other criteria that should be considered when selecting a core barrel sampler for soil sampling include sampling depth (see Guide D6286, for selection of drilling method), site accessibility, time constraints, and appropriate equipment availability.

6. Sampling Equipment

6.1 The types of core barrel samplers discussed in this practice are the split-barrel, ring-lined barrel, thin-walled tube, and solid-barrel samplers. These samplers are part of equipment that is either manually or mechanically powered, are designed to excavate a bore hole to the sampling depth, and may remain in the bore hole during the sample collection activity (i.e., cased bore hole or dual-walled casing).

6.1.1 *Split-Barrel Sampler*—As described in Methods D1586 and D4700, the split-barrel sampler is composed of a

³ The last approved version of this historical standard is referenced on www.astm.org.

core barrel cut in half along the length of the barrel, a hardened metal drive shoe (cutting tip) and a sample head that vents (e.g., a ball check valve) to allow air to be displaced as it is filled (see Fig. 1). The shoe and the head thread onto opposite ends of the split barrel and hold the two halves together. A common barrel size is 5.08 cm (2 in.) outside diameter and 3.81 cm (1.5 in.) inside diameter. The drive shoe used with this particular barrel size has an inside diameter of 3.49 cm (1.375 in.). If fitted with a liner for encasing the sample, the inside diameter of the core barrel liner should not be less than the drive shoe. Several other sizes of split-barrel samplers are available, with inside diameters ranging from 2.5 to 10 cm. A core barrel catcher (basket) can be used with this type of sampler to help retain non-cohesive materials. The split-barrel sampler is often used in conjunction with hollow-stem continuous-flight augers or an equivalent drilling or direct-push probe system (D4700 and D6282).

6.1.2 *Ring-Lined Barrel Sampler*—As described in Methods D3550 and D4700, the ring-lined barrel sampler consists of an intact barrel or two split-barrel halves, a drive shoe, rings, a waste barrel, and a sampler head that vents (e.g., a ball check valve) to allow air to be displaced as it is filled (Fig. 2). The rings, which come in various lengths and are made of several different materials, should fit snugly within the barrel. The

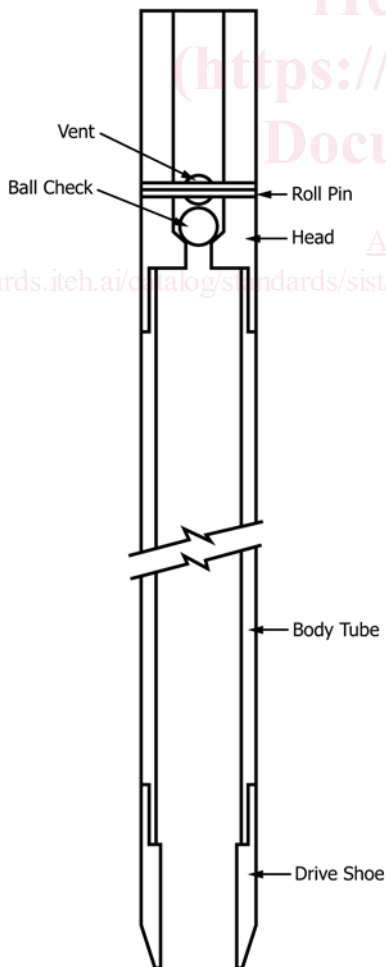

FIG. 1 Split Barrel Sampler

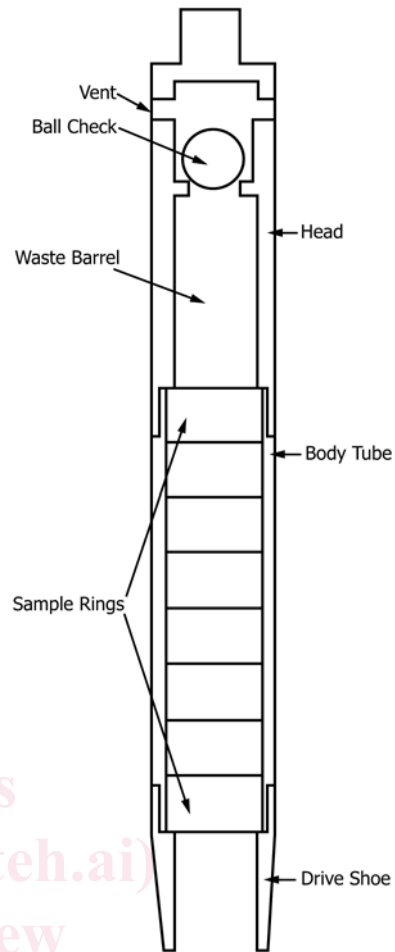

FIG. 2 Ring-Lined Barrel Sampler

inside diameter of the rings should not be less than that of the drive shoe opening. The lengths of the rings will depend on the sampling plan so as to either allow quick access to a cross section of the soil core at a depth of interest or allow the appropriate size sample to be collected (see section 8.1.2). The waste barrel section allows the rings to be filled with undisturbed soil by leaving space to contain the disturbed soil that often is present at the bottom of a hole. A core catcher (basket) can be used with this type of sampler to help retain non-cohesive materials. This sampler is often used in conjunction with hollow-stem continuous flight augers, or an equivalent drilling or direct-push probe system (D4700 and D6282).

6.1.3 *Thin-Walled Tube Sampler*—As described in Methods D1587 and D4700, the thin-walled tube sampler consists of a core barrel attached to a head (Fig. 3). The head connects to standard drill rods and contains a vent (e.g., a ball check valve) to allow air to be displaced as it is filled. This sampler description is unique to the Shelby tube, which is available with outside diameters of 5.08, 7.62, and 12.70 cm (2, 3, and 5 in.), and a length of approximately 0.91 m (36 in.). In all cases the drive end of the thin-walled tube sampler has a slightly smaller diameter than the inside of the tube. A core barrel catcher (basket) cannot be used with this type of sampler; therefore, non-cohesive materials may be lost during retrieval. These samplers are often used in conjunction with