INTERNATIONAL STANDARD



2491

INTERNATIONAL ORGANIZATION FOR STANDARDIZATION • МЕЖДУНАРОДНАЯ ОРГАНИЗАЦИЯ ПО СТАНДАРТИЗАЦИИ • ORGANISATION INTERNATIONALE DE NORMALISATION

Thin parallel keys and their corresponding keyways (Dimensions in millimetres)

Clavetage par clavettes parallèles minces (Dimensions en millimètres)

First edition – 1974-08-15

iTeh STANDARD PREVIEW
(standards.iteh.ai)

[ISO 2491:1974](https://standards.iteh.ai/catalog/standards/sist/5f68866f-ebef-4a32-ab7a-3c091a30acf3/iso-2491-1974)

<https://standards.iteh.ai/catalog/standards/sist/5f68866f-ebef-4a32-ab7a-3c091a30acf3/iso-2491-1974>

UDC 621.886.6 : 621.824.44

Ref. No. ISO 2491-1974 (E)

Descriptors : fasteners, cotter pins, dimensions, specifications.

FOREWORD

ISO (the International Organization for Standardization) is a worldwide federation of national standards institutes (ISO Member Bodies). The work of developing International Standards is carried out through ISO Technical Committees. Every Member Body interested in a subject for which a Technical Committee has been set up has the right to be represented on that Committee. International organizations, governmental and non-governmental, in liaison with ISO, also take part in the work.

Draft International Standards adopted by the Technical Committees are circulated to the Member Bodies for approval before their acceptance as International Standards by the ISO Council.

International Standard ISO 2491 was drawn up by Technical Committee ISO/TC 16, *Keys and keyways*, and circulated to the Member Bodies in August 1971.

It has been approved by the Member Bodies of the following countries:

Austria	India	Spain 2491:1974
Belgium	Japan	Sweden
Canada	Netherlands	Switzerland
Czechoslovakia	New Zealand	United Kingdom
Egypt, Arab Rep. of	Norway	U.S.S.R.
France	Romania	
Germany	South Africa, Rep. of	

No Member Body expressed disapproval of the document.

Thin parallel keys and their corresponding keyways (Dimensions in millimetres)

iTeh STANDARD PREVIEW (standards.iteh.ai)

1 SCOPE

This International Standard specifies the dimensional characteristics of thin parallel keys and of the corresponding keyways in shaft and hub.

It also specifies the material of these keys and gives the relation which should be observed between the diameter of shaft and the section of key.

2 FIELD OF APPLICATION

This International Standard is of general application for cylindrical shaft ends. It is recommended that the values given be adhered to even for special applications.

This kind of key is suitable for special applications, for example for keying in thin walls. For normal cases and when required because of the forces to be transmitted, the normal parallel keys and corresponding keyways in accordance with ISO/R 773 are to be used.

3 SHAPES, DIMENSIONS AND TOLERANCES OF KEYS

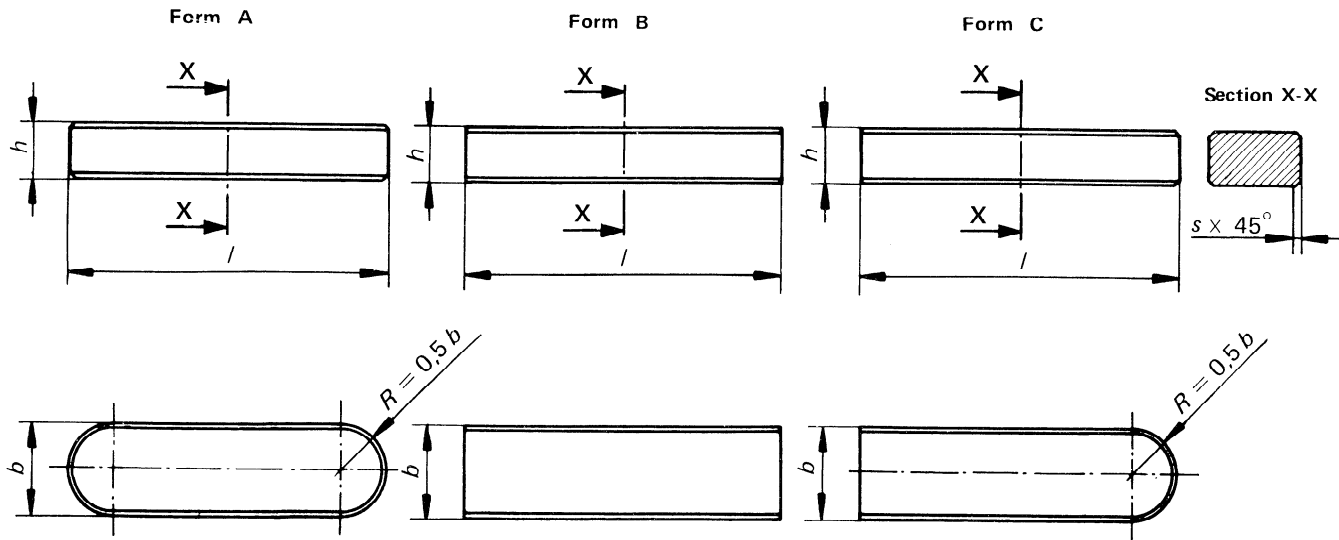

iTeh STANDARD PREVIEW
(standards.iteh.ai)

Values in millimetres

Width <i>b</i>		Thickness <i>h</i>		Chamfer ¹⁾		Length ²⁾	
nominal	tolerance h9	nominal	tolerance h11	min.	max.	from	to
5	0	3	0 -0,060	0,25	0,40	10	56
6	-0,030	4		0,25	0,40	14	70
8	0	5		0,25	0,40	18	90
10	-0,036	6	0 -0,075	0,40	0,60	22	110
12		6		0,40	0,60	28	140
14	0	6		0,40	0,60	36	160
16	-0,043	7		0,40	0,60	45	180
18		7		0,40	0,60	50	200
20		8	0 -0,090	0,60	0,80	56	220
22	0	9		0,60	0,80	63	250
25	-0,052	9		0,60	0,80	70	280
28		10		0,60	0,80	80	320
32	0	11	0 -0,110	0,60	0,80	90	360
36	-0,062	12		1,00	1,20	100	400

1) Only the longitudinal edges and those of the rounded ends shall be chamfered; the other edges shall be merely broken.

2) Lengths of the keys : 10, 12, 14, 16, 18, 20, 22, 25, 28, 32, 36, 40, 45, 50, 56, 63, 70, 80, 90, 100, 110, 125, 140, 160, 180, 200, 220, 250, 280, 320, 360 and 400.

4 MATERIAL

Steel having a tensile strength of not less than 590 N/mm² (60 kgf/mm²) in the finished condition, unless another specification is agreed between the interested parties.

NOTE – The mechanical properties of the steel will be completed later.

5 SHAPE, DIMENSIONS AND TOLERANCES OF KEYWAYS

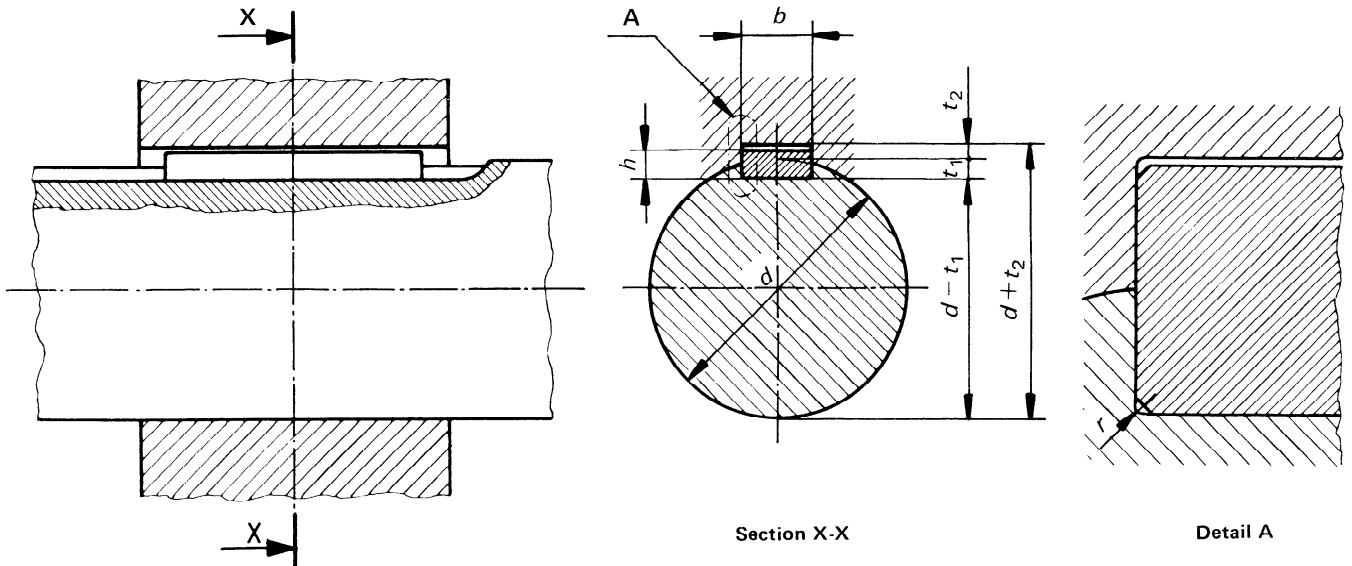

iTeh STANDARD PREVIEW
(standards.iteh.ai)

Values in millimetres

Shaft		Key ¹⁾ Section $b \times h$	Keyway											
Diameter d			Width b					Depth ²⁾				Radius r		
over	to	nominal	Tolerance for class fit						Shaft t_1		Hub t_2		max.	min.
				Free		Normal		Close	nom.	tol.	nom.	tol.	max.	min.
				Shaft H9	Hub D10	Shaft N9	Hub J _s 9							
12	17	5 × 3	5	+ 0,030	+ 0,078	0	± 0,015	- 0,012	1,8		1,4		0,25	0,16
17	22	6 × 4	6	0	+ 0,030	- 0,030	± 0,015	- 0,042	2,5		1,8		0,25	0,16
22	30	8 × 5	8	+ 0,036	+ 0,098	0	± 0,018	- 0,015	3	+ 0,1	2,3	+ 0,1	0,25	0,16
30	38	10 × 6	10	0	+ 0,040	- 0,036	± 0,018	- 0,051	3,5	0	2,8	0	0,40	0,25
38	44	12 × 6	12						3,5		2,8		0,40	0,25
44	50	14 × 6	14	+ 0,043	+ 0,120	0	+ 0,0215	- 0,018	3,5		2,8		0,40	0,25
50	58	16 × 7	16	0	+ 0,050	- 0,043	+ 0,0215	- 0,061	4		3,3		0,40	0,25
58	65	18 × 7	18						4		3,3		0,40	0,25
65	75	20 × 8	20						5		3,3		0,60	0,40
75	85	22 × 9	22	+ 0,052	+ 0,149	0	± 0,026	- 0,022	5,5	+ 0,2	3,8	+ 0,2	0,60	0,40
85	95	25 × 9	25	0	+ 0,065	- 0,052	± 0,026	- 0,074	5,5	0	3,8	0	0,60	0,40
95	110	28 × 10	28						6		4,3		0,60	0,40
110	130	32 × 11	32	+ 0,062	+ 0,180	0	± 0,031	- 0,026	7		4,4		0,60	0,40
130	150	36 × 12	36	0	+ 0,080	- 0,062	± 0,031	- 0,088	7,5		4,9		1,00	0,70

1) The relation between the diameter of the shaft and the section of the key must be strictly respected.

2) The depth of keyways in shafts and hubs shall be obtained by direct measurement or by measuring the dimensions $(d-t_1)$ and $(d+t_2)$. The tolerances applicable to t_1 and t_2 apply to these two composite dimensions $(d-t_1)$ and $(d+t_2)$, but the sign for the tolerance given in the table for t_1 has to be reversed. Keyway depths shall not be measured from the side corner. The tolerance on t_1 and t_2 is approximately equal to the tolerance k12 which would be obtained by adopting the thickness h of the key as the nominal size.

iTeh STANDARD PREVIEW

This page intentionally left blank
(standards.iteh.ai)

[ISO 2491:1974](#)

<https://standards.iteh.ai/catalog/standards/sist/5f68866f-ebef-4a32-ab7a-3c091a30acf3/iso-2491-1974>

iTeh STANDARD PREVIEW

This page intentionally left blank
(standards.iteh.ai)

[ISO 2491:1974](#)

<https://standards.iteh.ai/catalog/standards/sist/5f68866f-ebef-4a32-ab7a-3c091a30acf3/iso-2491-1974>

iTeh STANDARD PREVIEW

This page intentionally left blank
(standards.iteh.ai)

[ISO 2491:1974](#)

<https://standards.iteh.ai/catalog/standards/sist/5f68866f-ebef-4a32-ab7a-3c091a30acf3/iso-2491-1974>