

ETSI TS 123 273 V16.13.0 (2025-01)



**5G;
5G System (5GS) Location Services (LCS);
Stage 2
(3GPP TS 23.273 version 16.13.0 Release 16)**

[ETSI TS 123 273 V16.13.0 \(2025-01\)](https://standards.iteh.ai/catalog/standards/etsi/0a4945f4-5ffb-478c-ab8a-824453444cef/etsi-ts-123-273-v16-13-0-2025-01)

<https://standards.iteh.ai/catalog/standards/etsi/0a4945f4-5ffb-478c-ab8a-824453444cef/etsi-ts-123-273-v16-13-0-2025-01>



Reference

RTS/TSGS-0223273v16.13.0

Keywords

5G

ETSI

650 Route des Lucioles
F-06921 Sophia Antipolis Cedex - FRANCE

Tel.: +33 4 92 94 42 00 Fax: +33 4 93 65 47 16

Siret N° 348 623 562 00017 - APE 7112B
Association à but non lucratif enregistrée à la
Sous-Préfecture de Grasse (06) N° w061004871

Important notice

The present document can be downloaded from the
[ETSI Search & Browse Standards application](#).

The present document may be made available in electronic versions and/or in print. The content of any electronic and/or print versions of the present document shall not be modified without the prior written authorization of ETSI. In case of any existing or perceived difference in contents between such versions and/or in print, the prevailing version of an ETSI deliverable is the one made publicly available in PDF format on [ETSI deliver repository](#).

Users should be aware that the present document may be revised or have its status changed, this information is available in the [Milestones listing](#).

If you find errors in the present document, please send your comments to the relevant service listed under [Committee Support Staff](#).

If you find a security vulnerability in the present document, please report it through our [Coordinated Vulnerability Disclosure \(CVD\)](#) program.

Notice of disclaimer & limitation of liability

The information provided in the present deliverable is directed solely to professionals who have the appropriate degree of experience to understand and interpret its content in accordance with generally accepted engineering or other professional standard and applicable regulations.

No recommendation as to products and services or vendors is made or should be implied.

No representation or warranty is made that this deliverable is technically accurate or sufficient or conforms to any law and/or governmental rule and/or regulation and further, no representation or warranty is made of merchantability or fitness for any particular purpose or against infringement of intellectual property rights.

In no event shall ETSI be held liable for loss of profits or any other incidental or consequential damages.

Any software contained in this deliverable is provided "AS IS" with no warranties, express or implied, including but not limited to, the warranties of merchantability, fitness for a particular purpose and non-infringement of intellectual property rights and ETSI shall not be held liable in any event for any damages whatsoever (including, without limitation, damages for loss of profits, business interruption, loss of information, or any other pecuniary loss) arising out of or related to the use of or inability to use the software.

Copyright Notification

No part may be reproduced or utilized in any form or by any means, electronic or mechanical, including photocopying and microfilm except as authorized by written permission of ETSI.

The content of the PDF version shall not be modified without the written authorization of ETSI.

The copyright and the foregoing restriction extend to reproduction in all media.

© ETSI 2025.
All rights reserved.

Intellectual Property Rights

Essential patents

IPRs essential or potentially essential to normative deliverables may have been declared to ETSI. The declarations pertaining to these essential IPRs, if any, are publicly available for **ETSI members and non-members**, and can be found in ETSI SR 000 314: "*Intellectual Property Rights (IPRs); Essential, or potentially Essential, IPRs notified to ETSI in respect of ETSI standards*", which is available from the ETSI Secretariat. Latest updates are available on the [ETSI IPR online database](#).

Pursuant to the ETSI Directives including the ETSI IPR Policy, no investigation regarding the essentiality of IPRs, including IPR searches, has been carried out by ETSI. No guarantee can be given as to the existence of other IPRs not referenced in ETSI SR 000 314 (or the updates on the ETSI Web server) which are, or may be, or may become, essential to the present document.

Trademarks

The present document may include trademarks and/or tradenames which are asserted and/or registered by their owners. ETSI claims no ownership of these except for any which are indicated as being the property of ETSI, and conveys no right to use or reproduce any trademark and/or tradename. Mention of those trademarks in the present document does not constitute an endorsement by ETSI of products, services or organizations associated with those trademarks.

DECT™, **PLUGTESTS™**, **UMTS™** and the ETSI logo are trademarks of ETSI registered for the benefit of its Members. **3GPP™**, **LTE™** and **5G™** logo are trademarks of ETSI registered for the benefit of its Members and of the 3GPP Organizational Partners. **oneM2M™** logo is a trademark of ETSI registered for the benefit of its Members and of the oneM2M Partners. **GSM®** and the GSM logo are trademarks registered and owned by the GSM Association.

Legal Notice

This Technical Specification (TS) has been produced by ETSI 3rd Generation Partnership Project (3GPP).

The present document may refer to technical specifications or reports using their 3GPP identities. These shall be interpreted as being references to the corresponding ETSI deliverables. (2025-01)

The cross reference between 3GPP and ETSI identities can be found at [3GPP to ETSI numbering cross-referencing](#).

Modal verbs terminology

In the present document "**shall**", "**shall not**", "**should**", "**should not**", "**may**", "**need not**", "**will**", "**will not**", "**can**" and "**cannot**" are to be interpreted as described in clause 3.2 of the [ETSI Drafting Rules](#) (Verbal forms for the expression of provisions).

"**must**" and "**must not**" are **NOT** allowed in ETSI deliverables except when used in direct citation.

Contents

Intellectual Property Rights	2
Legal Notice	2
Modal verbs terminology.....	2
Foreword.....	6
1 Scope	8
2 References	8
3 Definitions and Abbreviations.....	9
3.1 Definitions	9
3.2 Abbreviations	10
4 Architecture Model and Concepts	10
4.1 General Concepts	10
4.1a Types of Location Request.....	11
4.1a.1 Network Induced Location Request (NI-LR)	11
4.1a.2 Mobile Terminated Location Request (MT-LR).....	11
4.1a.3 Mobile Originated Location Request (MO-LR)	11
4.1a.4 Immediate Location Request	11
4.1a.5 Deferred Location Request	11
4.1a.5.1 Types of event.....	11
4.1b LCS Quality of Service	12
4.2 Architectural Reference Model	13
4.2.1 Non-roaming reference architecture	13
4.2.2 Roaming reference architecture	14
4.2a Interconnection between 5GC and EPC	15
4.2a.1 General.....	15
4.2a.2 Non-roaming architecture	15
4.2a.3 Roaming architecture.....	16
4.2b Positioning methods	18
4.3 Functional description of LCS per network function	18
4.3.1 Access Network	18
4.3.2 LCS Clients, Application Functions and Network Functions	19
4.3.3 Gateway Mobile Location Centre, GMLC	19
4.3.4 Location Retrieval Function, LRF	20
4.3.5 UE.....	20
4.3.6 UDM.....	21
4.3.7 Access and Mobility Management Function, AMF.....	21
4.3.8 Location Management Function, LMF.....	21
4.3.9 Network Exposure Function, NEF.....	22
4.3.10 Unified Data Repository, UDR.....	22
4.4 Reference Point to Support Location Services	22
4.4.1 Le Reference Point.....	22
4.4.2 NL3 Reference Point	22
4.4.3 N1 Reference Point.....	22
4.4.4 N2 Reference Point	23
4.4.5 Void.....	23
4.4.6 NL5 Reference Point	23
4.4.7 NL2 Reference Point	23
4.4.8 NL6 Reference Point	23
4.4.9 N51 Reference Point.....	23
4.4.10 NL1 Reference Point	23
4.4.11 N52 Reference Point.....	23
4.4.12 NL7 Reference Point	23
4.5 Service Based Interfaces to Support Location Services	23
5 High Level Features	24

5.1	LMF Selection.....	24
5.1a	GMLC Discovery and Selection	24
5.2	3GPP access specific aspects.....	25
5.3	Non-3GPP Access Specific Aspects	25
5.3.1	Location Information for Non-3GPP Access.....	25
5.3.2	Access Type Selection for LCS Service	26
5.4	UE LCS privacy	27
5.4.1	General.....	27
5.4.2	Content of UE LCS Privacy Profile.....	27
5.4.2.1	General	27
5.4.2.2	Privacy Classes	28
5.4.2.2.1	Universal Class.....	28
5.4.2.2.2	Call/Session related Class.....	28
5.4.2.2.3	Call/Session unrelated Class.....	28
5.4.2.2.4	PLMN Operator Class	28
5.4.2.3	Location Privacy Indication (LPI).....	29
5.4.3	Provision of UE LCS privacy profile.....	29
5.4.4	Privacy Override Indicator (POI).....	29
5.4.5	LCS service authorization for an Immediate UE Location	29
5.4.6	LCS service authorization for a Deferred UE Location.....	30
5.5	Location service exposure	31
5.6	LCS Charging.....	33
5.7	Support of Concurrent Location Requests.....	33
5.7.1	General.....	33
5.7.2	Combining location requests by an H-GMLC or NEF	34
5.7.3	Combining location requests by a V-GMLC	34
5.7.4	Combining location requests by an AMF.....	34
5.7.5	Combining location requests by an LMF.....	34
5.7.6	Combining location requests by a UE.....	34
5.8	Interworking with the IMS	34
6	Location Service Procedures	35
6.1	5GC-MT-LR Procedure	35
6.1.1	5GC-MT-LR procedure for the regulatory location service	35
6.1.2	5GC-MT-LR Procedure for the commercial location service.....	36
6.2	5GC-MO-LR Procedure	40
6.3	Deferred 5GC-MT-LR Procedure for Periodic, Triggered and UE Available Location Events.....	43
6.3.1	Initiation and Reporting of Location Events.....	43
6.3.2	Cancellation of Reporting of Location Events by a UE.....	49
6.3.3	Cancellation of Reporting of Location Events by an AF or External LCS Client or GMLC	50
6.4	LMF Change Procedure	51
6.5	Unified Location Service Exposure Procedure.....	53
6.5.1	Unified Location Service Exposure Procedure without routing by a UDM	53
6.5.2	Unified Location Service Exposure Procedure with routing via a UDM.....	55
6.6	NG-RAN Location Service Exposure Procedure	56
6.7	Low Power Periodic and Triggered 5GC-MT-LR Procedures	56
6.7.1	Event Reporting with no change of LMF	57
6.7.2	Event Reporting with change of LMF	59
6.8	Bulk Operation of LCS Service Request Targeting to Multiple UEs.....	59
6.9	Procedures to Support Non-3GPP Access.....	62
6.9.1	Common Positioning Procedures when a UE is served by only one PLMN	62
6.9.2	MT-LR Procedures when a UE is served by Different PLMNs for 3GPP Access and Non-3GPP Access.....	64
6.9.3	MO-LR Procedures when UE is served by the Different PLMNs via 3GPP Access and Non-3GPP Access.....	67
6.9.4	NI-LR Procedures when a UE is served by Different PLMNs for 3GPP access and non-3GPP access.....	67
6.10	Procedures dedicated to Support Regulatory services	67
6.10.1	5GC-NI-LR Procedure.....	67
6.10.2	5GC-MT-LR Procedure without UDM Query.....	69
6.10.3	Location continuity for Handover of an Emergency session from NG-RAN	70
6.11	Common Sub-Procedures.....	71
6.11.1	UE Assisted and UE Based Positioning Procedure.....	71

6.11.2	Network Assisted Positioning Procedure.....	73
6.11.3	Obtaining Non-UE Associated Network Assistance Data	73
6.12	UE Location Privacy Setting Procedure	75
6.12.1	UE Location Privacy Setting Procedure Initiated by UE.....	75
6.12.2	UE Location Privacy Setting Procedure Initiated by AF.....	75
6.13	Procedures with interaction between 5GC and EPC	76
6.13.1	MT-LR Procedure.....	76
6.13.2	MO-LR Transfer to a Third Party Procedure.....	77
6.14	Procedures for Broadcast of Assistance Data	78
6.14.1	Broadcast of Assistance Data by an LMF.....	78
6.14.2	Delivery of Cipherring Keys to UEs for Broadcast Assistance Data	79
7	Information storage	81
7.1	UDM	81
7.2	GMLC	83
7.2.1	Information for an LCS Client.....	83
8	Network Function Services	85
8.1	AMF Services.....	85
8.2	UDM Services	85
8.3	LMF Services	85
8.3.1	General.....	85
8.3.2	Nlmf_Location service	85
8.3.2.1	General	85
8.3.2.2	Nlmf_Location_DetermineLocation service operation	85
8.3.2.3	Nlmf_Location_EventNotify service operation	86
8.3.2.4	Nlmf_Location_CancelLocation service operation.....	86
8.3.2.5	Nlmf_Location_LocationContextTransfer service operation.....	86
8.3.3	Nlmf_Broadcast service.....	87
8.3.3.1	General	87
8.3.3.2	Nlmf_Broadcast_CipherringKeyData service operation.....	87
8.4	GMLC Services.....	87
8.4.1	General.....	87
8.4.2	Ngmlc_Location service	88
8.4.2.1	General	88
8.4.2.2	Ngmlc_Location_ProvideLocation service operation	88
8.4.2.3	Ngmlc_Location_LocationUpdate service operation.....	88
8.4.2.4	Ngmlc_Location_EventNotify service operation.....	89
8.4.2.5	Ngmlc_Location_CancelLocation service operation	89
8.4.2.6	Ngmlc_Location_LocationUpdateNotify service operation	89
8.5	NEF Services.....	90
8.6	UDR Services.....	90
Annex A (informative):	Differences with TS 23.271 [4]	91
A.0	General	91
A.1	Differences in Parameters for a Location Request.....	91
A.2	Differences in Information Storage in the UDR/UDM versus HSS/GMLC for EPS.....	91
A.3	Differences in Information Storage in the GMLC	92
A.4	Differences with TS 23.271 [4] on Privacy.....	93
A.4.1	Differences in UE LCS Privacy	93
Annex B (informative):	LCS privacy selection rule in serving NF	95
B.1	LCS privacy selection flow rule.....	95
Annex C (informative):	Change history	96
History		99

Foreword

This Technical Specification has been produced by the 3rd Generation Partnership Project (3GPP).

The contents of the present document are subject to continuing work within the TSG and may change following formal TSG approval. Should the TSG modify the contents of the present document, it will be re-released by the TSG with an identifying change of release date and an increase in version number as follows:

Version x.y.z

where:

- x the first digit:
 - 1 presented to TSG for information;
 - 2 presented to TSG for approval;
 - 3 or greater indicates TSG approved document under change control.
- y the second digit is incremented for all changes of substance, i.e. technical enhancements, corrections, updates, etc.
- z the third digit is incremented when editorial only changes have been incorporated in the document.

In the present document, modal verbs have the following meanings:

- shall** indicates a mandatory requirement to do something
- shall not** indicates an interdiction (prohibition) to do something

The constructions "shall" and "shall not" are confined to the context of normative provisions, and do not appear in Technical Reports.

The constructions "must" and "must not" are not used as substitutes for "shall" and "shall not". Their use is avoided insofar as possible, and they are not used in a normative context except in a direct citation from an external, referenced, non-3GPP document, or so as to maintain continuity of style when extending or modifying the provisions of such a referenced document.

- should** indicates a recommendation to do something
- should not** indicates a recommendation not to do something
- may** indicates permission to do something
- need not** indicates permission not to do something

The construction "may not" is ambiguous and is not used in normative elements. The unambiguous constructions "might not" or "shall not" are used instead, depending upon the meaning intended.

- can** indicates that something is possible
- cannot** indicates that something is impossible

The constructions "can" and "cannot" are not substitutes for "may" and "need not".

- will** indicates that something is certain or expected to happen as a result of action taken by an agency the behaviour of which is outside the scope of the present document
- will not** indicates that something is certain or expected not to happen as a result of action taken by an agency the behaviour of which is outside the scope of the present document
- might** indicates a likelihood that something will happen as a result of action taken by some agency the behaviour of which is outside the scope of the present document

might not indicates a likelihood that something will not happen as a result of action taken by some agency the behaviour of which is outside the scope of the present document

In addition:

is (or any other verb in the indicative mood) indicates a statement of fact

is not (or any other negative verb in the indicative mood) indicates a statement of fact

The constructions "is" and "is not" do not indicate requirements.

iTeh Standards
(<https://standards.iteh.ai>)
Document Preview

[ETSI TS 123 273 V16.13.0 \(2025-01\)](https://standards.iteh.ai/catalog/standards/etsi/0a4945f4-5ffb-478c-ab8a-824453444cef/etsi-ts-123-273-v16-13-0-2025-01)

<https://standards.iteh.ai/catalog/standards/etsi/0a4945f4-5ffb-478c-ab8a-824453444cef/etsi-ts-123-273-v16-13-0-2025-01>

1 Scope

The present document specifies the stage 2 of the service-based architecture used for location services in the 5G system, and corresponding Network Functions (NFs), NF services and procedures, to meet the service requirements defined in TS 22.261 [3] and TS 22.071 [2].

Location Services specified in the present document include regulatory location services and commercial location services. The architecture and signalling procedures in NG-RAN are defined in TS 38.305 [9].

2 References

The following documents contain provisions which, through reference in this text, constitute provisions of the present document.

- References are either specific (identified by date of publication, edition number, version number, etc.) or non-specific.
- For a specific reference, subsequent revisions do not apply.
- For a non-specific reference, the latest version applies. In the case of a reference to a 3GPP document (including a GSM document), a non-specific reference implicitly refers to the latest version of that document *in the same Release as the present document*.

- [1] 3GPP TR 21.905: "Vocabulary for 3GPP Specifications".
- [2] 3GPP TS 22.071: "Technical Specification Group Systems Aspects; Location Services (LCS)".
- [3] 3GPP TS 22.261: "Service requirements for next generation new services and markets; Stage 1".
- [4] 3GPP TS 23.271: "Functional stage 2 description of Location Services (LCS)".
- [5] 3GPP TS 43.059: "Functional Stage 2 description of Location Services in GERAN".
- [6] Void.
- [7] 3GPP TS 36.305: "Stage 2 functional specification of User Equipment (UE) positioning in E-UTRAN".
- [8] 3GPP TS 23.032: "Universal Geographical Area Description (GAD)".
- [9] 3GPP TS 38.305: "Stage 2 functional specification of User Equipment (UE) positioning in NG-RAN".
- [10] 3GPP TS 23.167: "IP Multimedia Subsystem (IMS) emergency sessions".
- [11] 3GPP TS 24.501: "Non-Access-Stratum (NAS) protocol for 5G System (5GS); Stage 3".
- [12] 3GPP TS 29.572: "5G System; Location Management Services; Stage 3".
- [13] OMA MLP TS: "Mobile Location Protocol", [<http://www.openmobilealliance.org>].
- [14] OMA RLP TS: "Roaming Location Protocol", [<http://www.openmobilealliance.org>].
- [15] 3GPP TS 38.455: "NG-RAN; NR Positioning Protocol A (NRPPa)".
- [16] 3GPP TS 29.518: "5G System; Access and Mobility Management Services; Stage 3".
- [17] 3GPP TS 25.305: "Stage 2 functional specification of User Equipment (UE) positioning in UTRAN".
- [18] 3GPP TS 23.501: "System Architecture for the 5G System; Stage 2".
- [19] 3GPP TS 23.502: "Procedures for the 5G System; Stage 2".

- [20] 3GPP TS 36.355: "Evolved Universal Terrestrial Radio Access (E-UTRA); LTE Positioning Protocol (LPP)".
- [21] 3GPP TS 23.316: "Wireless and wireline convergence access support for the 5G System (5GS)".
- [22] ETSI ES 282 004: "Telecommunications and Internet converged Services and Protocols for Advanced Networking (TISPAN); NGN Functional Architecture; Network Attachment Sub-System (NASS)".
- [23] ITU-T Recommendation E.164: "The international public telecommunication numbering plan".
- [24] 3GPP TS 23.222: "Common Application Programming Interface (API) framework for 3GPP northbound APIs".
- [25] RFC 2396: "Uniform Resource Identifiers".
- [26] RFC 3261: "SIP: Session Initiation Protocol".
- [27] 3GPP TS 23.228: "IP multimedia subsystem (IMS)".
- [28] 3GPP TS 23.003: "Numbering, addressing and identification".
- [29] 3GPP TS 29.002: "Mobile Application Part (MAP) specification".
- [30] 3GPP TS 32.271: "Telecommunication management; Charging management; Location Services (LCS) charging".
- [31] 3GPP TS 32.298: "Telecommunication management; Charging management; Charging Data Record (CDR) parameter description".
- [32] Void.
- [33] 3GPP TS 29.571: "5G System; Common Data Types for Service Based Interfaces; Stage 3".
- [34] 3GPP TS 29.171: "Location Services (LCS); LCS Application Protocol (LCS-AP) between the Mobile Management Entity (MME) and Evolved Serving Mobile Location Centre (E-SMLC); SLs interface".
- [35] 3GPP TS 29.122: "T8 reference point for Northbound APIs".
- [36] 3GPP TS 24.571: "5G System (5GS); Control plane Location Services (LCS) procedures; Stage 3".

3 Definitions and Abbreviations

3.1 Definitions

For the purposes of the present document, the terms and definitions given in TR 21.905 [1] and the following apply. A term defined in the present document takes precedence over the definition of the same term, if any, in TR 21.905 [1].

LCS Client: entity that interacts with GMLC for the purpose of obtaining location information for one or more UEs. The LCS Client may reside in the UE.

For the purposes of the present document, the following terms and definitions given in TS 23.271 [4] apply:

Call Related: see TS 23.271 [4].

Codeword: see TS 23.271 [4].

Current Location: see TS 23.271 [4].

Deferred location request: see TS 23.271 [4].

Immediate location request: see TS 23.271 [4].

Last Known Location: see TS 23.271 [4].

LCS (LoCation Services): see TS 23.271 [4].

Location Estimate: see TS 23.271 [4].

Pseudonym: see TS 23.271 [4].

Pseudonym mediation device: Functionality that verifies pseudonyms to verinym.

Requestor: see TS 23.271 [4].

Requestor Identity: see TS 23.271 [4].

Response Method: for LCS Client using the OMA MLP protocol. Detail see TS 23.271 [4].

Service Type: see TS 23.271 [4].

Target UE: see TS 23.271 [4].

Velocity: see TS 23.271 [4].

Verinym: see TS 23.271 [4].

3.2 Abbreviations

For the purposes of the present document, the abbreviations given in TR 21.905 [1] and the following apply. An abbreviation defined in the present document takes precedence over the definition of the same abbreviation, if any, in TR 21.905 [1].

APN	Access Point Name
APN-NI	APN Network Identifier
EDT	Early Data Transmission
E-SMLC	Evolved Serving Mobile Location Centre
GMLC	Gateway Mobile Location Centre
HGMLC	Home GMLC
LCS	LoCation Services
LDR	Location Deferred Request
LMF	Location Management Function
LPI	LCS Privacy Indicator
LRF	Location Retrieval Function
MO-LR	Mobile Originated Location Request
MT-LR	Mobile Terminated Location Request
NI-LR	Network Induced Location Request
PMD	Pseudonym mediation device functionality
POI	Privacy Override Indicator
TNAN	Trusted Non-3GPP Access Network
UNAN	Untrusted Non-3GPP Access Network
VGMLC	Visited GMLC

4 Architecture Model and Concepts

4.1 General Concepts

A general description of location services and service requirements are given in the specification TS 22.071 [2]. Support of location services for GERAN, UTRAN and E-UTRAN access networks is described in TS 23.271 [4], TS 43.059 [5], TS 25.305 [17] and TS 36.305 [7].

The positioning of a UE can be supported by RAT dependent position methods, which rely on for example 3GPP RAT measurements obtained by a target UE and/or on measurements obtained by an Access Network of 3GPP RAT signals

transmitted by a target UE. Positioning of a UE can also be supported by RAT independent position methods which may rely on non-RAT measurements obtained by a UE and/or on other information.

The positioning of a UE can be performed by either 3GPP access network or non-3GPP access network. A proper access type shall be determined to assure that the positioning result can fulfil the requested QoS and operator policy.

Location information for one or multiple target UEs may be requested by and reported to an LCS client or an AF within or external to a PLMN, or a control plane NF within a PLMN. Location information contained in the location request and location information contained in the location response are defined in clause 5.5.

For location request from LCS client (neither in the UE nor in the NG-RAN) or AF external to a PLMN, privacy verification of the target UE shall be enabled to check whether it is allowed to acquire the UE location information based on UE LCS privacy profile and whether the LCS client or the AF is authorised to use the location service as defined in clause 5.4. Additionally, UEs may optionally support privacy notification and verification on behalf of a user. Privacy override is also supported for regulatory LCS services according to local regulation.

The capabilities of a target UE to support LCS may be signalled by the UE to a serving PLMN at the AS, NAS and application (positioning protocol) levels to enable use of position methods supported by the UE.

To provide Location Service in the EPC interworking scenario, an EPC and 5GC common interface shall be used for the location request from LCS client or AF.

4.1a Types of Location Request

4.1a.1 Network Induced Location Request (NI-LR)

With a Network Induced Location Request (NI-LR), a serving AMF for a UE initiates location of the UE for some regulatory service (e.g. an emergency call from the UE).

4.1a.2 Mobile Terminated Location Request (MT-LR)

With a Mobile Terminated Location Request (MT-LR), an LCS client or AF external to or internal to a serving PLMN sends a location request to the PLMN (which may be the HPLMN or VPLMN) for the location of a target UE.

4.1a.3 Mobile Originated Location Request (MO-LR)

With a Mobile Originated Location Request (MO-LR), a UE sends a request to a serving PLMN for location related information for the UE.

4.1a.4 Immediate Location Request

With an immediate location request, an LCS client or AF sends or instigates a location request for a target UE (or group of target UEs) and expects to receive a response containing location information for the target UE (or group of target UEs) within a short time period which may be specified using QoS. An immediate location request may be used for an NI-LR, MT-LR or MO-LR.

4.1a.5 Deferred Location Request

With a deferred location request, an LCS client or AF sends a location request to a PLMN for a target UE (or group of target UEs) and expects to receive a response containing the indication of event occurrence and location information if requested for the target UE (or group of target UEs) at some future time (or times), which may be associated with specific events associated with the target UE (or group of target UEs). In this version of the specification, only deferred location requests for an MT-LR are supported.

4.1a.5.1 Types of event

The following types of event are defined for a deferred location request.

- a) UE availability: Any event in which the 5GCN has established a contact with the UE. This event is considered to be applicable when the UE is temporarily unavailable due to inaction by the user, or for temporarily loss of radio connectivity or IMSI detach and so on. The UE Available event only requires one response to an LCS client/AF and after this response, the UE Available event is concluded.
- b) Area: An event where the UE enters, leaves or remains within a pre-defined geographical area. At least one type of area event can be defined (i.e. entering, leaving or remaining within the area). The LCS client or AF may define the target area as a geographical area or as a geopolitical name of an area. The PLMN may translate and define the target area as the identities of one or more radio cells or tracking areas. The area event may be reported one time only, or multiple times. The area event report shall contain an indication of the event occurrence. The location estimate may be included in the report. If an area event is detected by the UE but an event report cannot be sent (e.g. because the UE cannot access the network or due to a minimum reporting interval), a report shall be sent later when possible irrespective of whether the area event still applies for the current UE location. Area event reporting is controlled by a minimum and a maximum reporting time. The minimum reporting time defines the minimum allowed time between successive area events. The maximum reporting time defines the maximum time between successive reports. When a UE sends a report due to expiration of the maximum reporting time, the UE indicates expiration of the maximum reporting time as the trigger event. The maximum reporting time enables the AF, LCS client and HGMLC to remain aware of continuing support by the UE for the area event (e.g. to detect if area event reporting may have been aborted due to UE power off).
- c) Periodic Location: An event where a defined periodic timer expires in the UE and activates a location report. If a periodic event is detected by the UE but an event report cannot be sent (e.g. because the UE cannot access the network temporarily), a report shall be sent later when possible and the periodic timer for the next event shall then be started. The reporting duration for periodic location shall equal the requested number of reports multiplied by the periodic interval even when reports are delayed.
- d) Motion: An event where the UE moves by more than some predefined straight line distance from a previous location. The motion event may be reported one time only, or multiple times. The motion event report shall contain an indication of the event occurrence. A location estimate may be included in the report if requested by the LCS client or AF. For successive motion event reports, motion is determined relative to the UE location corresponding to the immediately preceding event report (including an event report triggered by expiration of the maximum reporting time). If a motion event is detected by the UE but an event report is deferred (e.g. because the UE cannot access the network temporarily), a report shall be sent later when possible irrespective of whether the motion event still applies to the current UE location. Motion reporting is controlled by a minimum and a maximum reporting time. The minimum reporting time defines the minimum allowed time between successive event reports. The maximum reporting time defines the maximum time between successive reports. When a UE sends a report due to expiration of the maximum reporting time, the UE indicates expiration of the maximum reporting time as the trigger event. The maximum reporting time enables the AF, LCS client and HGMLC to remain aware of continuing support by the UE for the motion event (e.g. to detect if motion event reporting may have been aborted due to UE power off).

4.1b LCS Quality of Service

LCS Quality of Service is used to characterise the location request. It can either be determined by the operator or determined based on the negotiation with the LCS client or the AF. It is optional for LCS client or the AF to provide the LCS Quality of Service in the location request.

LCS Quality of Service information is characterised by 3 key attributes:

- LCS QoS Class as defined below.
- Accuracy: i.e. Horizontal Accuracy (see clause 4.3.1 of TS 22.071 [2]) and Vertical Accuracy (see clause 4.3.2 of TS 22.071 [2]).
- Response Time (e.g. no delay, low delay or delay tolerant as described in clause 4.3.3 of TS 22.071 [2]).

The LCS QoS Class defines the degree of adherence by the Location Service to another quality of service parameter (Accuracy), if requested. The 5G system shall attempt to satisfy the other quality of service parameter regardless of the use of QoS Class. There are 2 LCS QoS Classes:

- Best Effort Class: This class defines the least stringent requirement on the QoS achieved for a location request. If a location estimate obtained does not fulfil the other QoS requirements, it should still be returned but with an

appropriate indication that the requested QoS was not met. If no location estimate is obtained, an appropriate error cause is sent.

- Assured Class: This class defines the most stringent requirement on the accuracy achieved for a location request. If a location estimate obtained does not fulfil the other QoS requirements, then it shall be discarded, and an appropriate error cause shall be sent.

For LCS client, it may indicate accuracy defined in TS 29.572 [12], tables 6.1.6.3.2-1 and 6.1.6.3.5-1. For AF, it may either indicate the accuracy defined in TS 29.572 [12], table 6.1.6.3.2-1, or indicate a particular value e.g. PLMN ID defined in TS 29.122 [35], table 5.3.2.4.7-1.

4.2 Architectural Reference Model

4.2.1 Non-roaming reference architecture

Figure 4.2.1-1 shows an architectural reference model for 5GS LCS for a non-roaming UE in reference point representation.

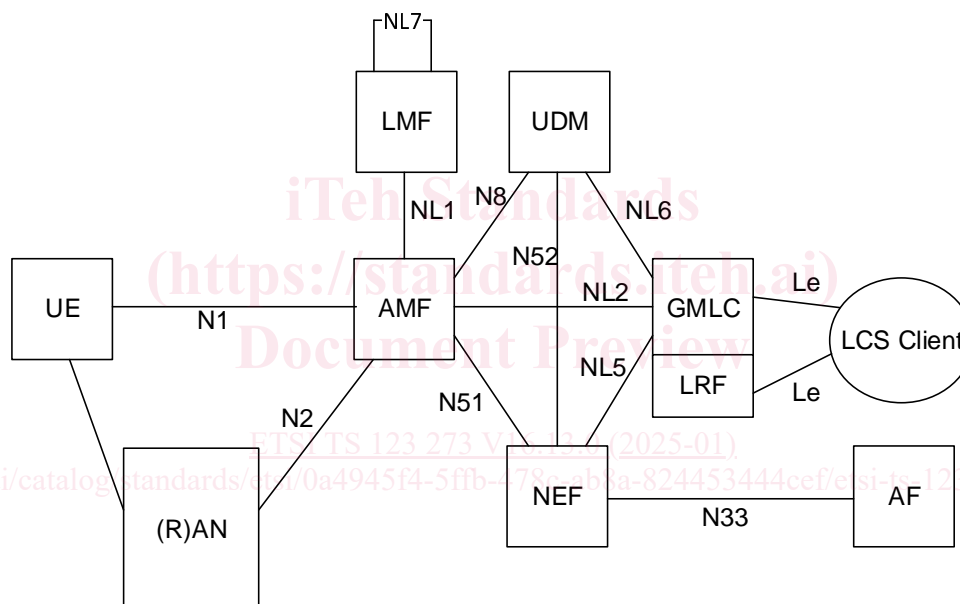

Figure 4.2.1-1: Non-roaming reference architecture for Location Services in reference point representation

NOTE 1: (R)AN represents NG-RAN, trusted non-3GPP access or untrusted non-3GPP access.

NOTE 2: Reference point interface related to charging functionality is not shown in this specification.

Figure 4.2.1-2 shows an architectural reference model for 5GS LCS for a non-roaming UE in SBI representation.