

FINAL
DRAFT

INTERNATIONAL
STANDARD

ISO/FDIS
22941

ISO/TC 45/SC 4

Secretariat: DSM

Voting begins on:
2021-06-02

Voting terminates on:
2021-07-28

Rubber sheets for livestock — Dairy cattle — Specification

*Feuille de caoutchouc pour le bétail — Bovins laitiers —
Spécifications*

iTeh STANDARD PREVIEW
(standards.iteh.ai)

[ISO/FDIS 22941](https://standards.iteh.ai/catalog/standards/sist/5fc210fd-4c3f-4ba9-b42d-8a059ac47745/iso-fdis-22941)

<https://standards.iteh.ai/catalog/standards/sist/5fc210fd-4c3f-4ba9-b42d-8a059ac47745/iso-fdis-22941>

RECIPIENTS OF THIS DRAFT ARE INVITED TO SUBMIT, WITH THEIR COMMENTS, NOTIFICATION OF ANY RELEVANT PATENT RIGHTS OF WHICH THEY ARE AWARE AND TO PROVIDE SUPPORTING DOCUMENTATION.

IN ADDITION TO THEIR EVALUATION AS BEING ACCEPTABLE FOR INDUSTRIAL, TECHNOLOGICAL, COMMERCIAL AND USER PURPOSES, DRAFT INTERNATIONAL STANDARDS MAY ON OCCASION HAVE TO BE CONSIDERED IN THE LIGHT OF THEIR POTENTIAL TO BECOME STANDARDS TO WHICH REFERENCE MAY BE MADE IN NATIONAL REGULATIONS.



Reference number
ISO/FDIS 22941:2021(E)

© ISO 2021

iTeh STANDARD PREVIEW (standards.iteh.ai)

ISO/FDIS 22941

<https://standards.iteh.ai/catalog/standards/sist/5fc210fd-4c3f-4ba9-b42d-8a059ac47745/iso-fdis-22941>



COPYRIGHT PROTECTED DOCUMENT

© ISO 2021

All rights reserved. Unless otherwise specified, or required in the context of its implementation, no part of this publication may be reproduced or utilized otherwise in any form or by any means, electronic or mechanical, including photocopying, or posting on the internet or an intranet, without prior written permission. Permission can be requested from either ISO at the address below or ISO's member body in the country of the requester.

ISO copyright office
CP 401 • Ch. de Blandonnet 8
CH-1214 Vernier, Geneva
Phone: +41 22 749 01 11
Email: copyright@iso.org
Website: www.iso.org

Published in Switzerland

Contents

	Page
Foreword	iv
1 Scope	1
2 Normative references	1
3 Terms and definitions	1
4 Classification	1
5 Requirements	2
5.1 General	2
5.2 Dimensions	2
5.3 Physical properties	2
6 Labelling	2
Annex A (normative) Liquid resistance	4
Annex B (normative) Deformability	5
Annex C (normative) Slip resistance	8
Bibliography	10

iTeh STANDARD PREVIEW (standards.iteh.ai)

[ISO/FDIS 22941](https://standards.iteh.ai/catalog/standards/sist/5fc210fd-4c3f-4ba9-b42d-8a059ac47745/iso-fdis-22941)

<https://standards.iteh.ai/catalog/standards/sist/5fc210fd-4c3f-4ba9-b42d-8a059ac47745/iso-fdis-22941>

Foreword

ISO (the International Organization for Standardization) is a worldwide federation of national standards bodies (ISO member bodies). The work of preparing International Standards is normally carried out through ISO technical committees. Each member body interested in a subject for which a technical committee has been established has the right to be represented on that committee. International organizations, governmental and non-governmental, in liaison with ISO, also take part in the work. ISO collaborates closely with the International Electrotechnical Commission (IEC) on all matters of electrotechnical standardization.

The procedures used to develop this document and those intended for its further maintenance are described in the ISO/IEC Directives, Part 1. In particular, the different approval criteria needed for the different types of ISO documents should be noted. This document was drafted in accordance with the editorial rules of the ISO/IEC Directives, Part 2 (see www.iso.org/directives).

Attention is drawn to the possibility that some of the elements of this document may be the subject of patent rights. ISO shall not be held responsible for identifying any or all such patent rights. Details of any patent rights identified during the development of the document will be in the Introduction and/or on the ISO list of patent declarations received (see www.iso.org/patents).

Any trade name used in this document is information given for the convenience of users and does not constitute an endorsement.

For an explanation of the voluntary nature of standards, the meaning of ISO specific terms and expressions related to conformity assessment, as well as information about ISO's adherence to the World Trade Organization (WTO) principles in the Technical Barriers to Trade (TBT), see www.iso.org/iso/foreword.html.

This document was prepared by Technical Committee ISO/TC 45, *Rubber and rubber products*, Subcommittee SC 4, *Products (other than hoses)*. [ISO/FDIS 22941](https://standards.iteh.ai/catalog/standards/sist/5fc210fd-4c3f-4ba9-b42d-fc591d75451d/iso-fdis-22941)

Any feedback or questions on this document should be directed to the user's national standards body. A complete listing of these bodies can be found at www.iso.org/members.html.

Rubber sheets for livestock — Dairy cattle — Specification

1 Scope

This document specifies the characteristics of solid rubber sheets for dairy cattle. These sheets are used in a walking or lying area. This document does not include design of the product.

2 Normative references

The following documents are referred to in the text in such a way that some or all of their content constitutes requirements of this document. For dated references, only the edition cited applies. For undated references, the latest edition of the referenced document (including any amendments) applies.

ISO 37, *Rubber, vulcanized or thermoplastic — Determination of tensile stress-strain properties*

ISO 48-4, *Rubber, vulcanized or thermoplastic — Determination of hardness — Part 4: Indentation hardness by durometer method (Shore hardness)*

ISO 188, *Rubber, vulcanized or thermoplastic — Accelerated ageing and heat resistance tests*

ISO 815-1:2019, *Rubber, vulcanized or thermoplastic — Determination of compression set — Part 1: At ambient or elevated temperatures*

ISO 1817, *Rubber, vulcanized or thermoplastic — Determination of the effect of liquids*

ISO 3302-1, *Rubber — Tolerances for products — Part 1: Dimensional tolerances*

ISO 4649:2017, *Rubber, vulcanized or thermoplastic — Determination of abrasion resistance using a rotating cylindrical drum device*

ISO 5893, *Rubber and plastics test equipment — Tensile, flexural and compression types (constant rate of traverse) — Specification*

3 Terms and definitions

For the purposes of this document, the following terms and definitions apply.

ISO and IEC maintain terminological databases for use in standardization at the following addresses:

— ISO Online browsing platform: available at <https://www.iso.org/obp>

— IEC Electropedia: available at <http://www.electropedia.org/>

3.1

walking area

passage or area where cattle walk through in housing and stand for milking

3.2

lying area

area where cattle rest in housing

4 Classification

A rubber sheet is classified into two types depending on the application:

— walking area;

— lying area.

5 Requirements

5.1 General

Under visual inspection, the rubber sheet shall be free from any visual defects such as foreign materials, holes, blisters, porosity and indentations that may adversely affect performance and appearance.

5.2 Dimensions

The length, width and thickness of the rubber sheets shall be agreed between the interested parties. The tolerances of all dimensions shall conform to ISO 3302-1 class M4.

At least three measurements of each dimension shall be determined, and the median value of each dimension reported.

5.3 Physical properties

The physical properties of rubber sheets shall comply with the requirements given in [Table 1](#).

The nominal hardness of the rubber sheets shall be as agreed between the purchasers and the manufacturers with tolerance ± 5 Shore A.

Table 1 — Physical properties requirements
(standards.iteh.ai)

Physical properties	Requirement		Test method
	Walking area	Lying area	
Hardness, Shore A	50 to 80	50 to 80	ISO 48-4
Tensile strength, MPa, min.	3	3	ISO 37, dumbbell type 1
Elongation at break, %, min.	80	80	ISO 37, dumbbell type 1
After accelerated-ageing test			ISO 188, air-oven method, (70 ± 1) °C, (72 ± 2) h
— Change in hardness, Shore A, max.	±5	±5	
— Change in tensile strength, %, max.	±20	±20	
— Change in elongation at break, %, max.	±30	±30	
Abrasion resistance, mm ³ , max.	300	300	ISO 4649:2017, method A
Compression set, %, max.	40	25	ISO 815-1:2019, method A (70 ± 1) °C, 24 ₋₂ ⁰ h,
Liquid resistance, %, max.			Annex A
— Change in hardness	±20	±20	
— Change in mass	±20	±20	
Deformability, mm	1,0 to 9,0	≥ 5,0	Annex B
Slip resistance, coefficient of friction (both wet and dry conditions)	≥ 0,40	≥ 0,40	Annex C

6 Labelling

The product label shall contain the following information:

- a) product name;
- b) product type: walking area or lying area;

- c) size: width, length and thickness;
- d) manufacturer's or supplier's identification;
- e) date of manufacture and/or manufacturer's identifying lot number.

iTeh STANDARD PREVIEW
(standards.iteh.ai)

[ISO/FDIS 22941](https://standards.iteh.ai/catalog/standards/sist/5fc210fd-4c3f-4ba9-b42d-8a059ac47745/iso-fdis-22941)

<https://standards.iteh.ai/catalog/standards/sist/5fc210fd-4c3f-4ba9-b42d-8a059ac47745/iso-fdis-22941>

Annex A (normative)

Liquid resistance

A.1 Chemical reagents

A.1.1 Ammonia, 2 % mass fraction aqueous solution.

A.1.2 Stall disinfectant, peracetic acid, 3 g/kg aqueous solution.

A.2 Procedure

The preparation and number of test pieces including test procedure shall comply with ISO 1817. The test chemicals include ammonia ([A.1.1](#)) and stall disinfectant ([A.1.2](#)).

The immersion time shall be 7 days \pm 2 h at standard laboratory temperature.

The physical properties concerned in the service application should be mass change (in accordance with ISO 1817) and hardness change (in accordance with ISO 48-4).

ITEH STANDARD PREVIEW
(standards.iteh.ai)

[ISO/FDIS 22941](#)

<https://standards.iteh.ai/catalog/standards/sist/5fc210fd-4c3f-4ba9-b42d-8a059ac47745/iso-fdis-22941>

Annex B (normative)

Deformability

B.1 Apparatus

B.1.1 Compression-testing machine, complying with the requirement of ISO 5893, equipped with means of autographic recording of the force-deformation relationship to an accuracy corresponding to grade 1 in respect of force.

B.1.2 Indentors, made of steel. For the walking area test, the indenter consisting of two mounted hoof segments with a standing area of (75 ± 5) cm² is employed (see [Figure B.1](#)). For the lying area test, the calotte shaped indenter is employed (see [Figure B.2](#)).

NOTE The standing area corresponds to that of a cow's foot.

iTeh STANDARD PREVIEW
(standards.iteh.ai)

[ISO/FDIS 22941](#)

<https://standards.iteh.ai/catalog/standards/sist/5fc210fd-4c3f-4ba9-b42d-8a059ac47745/iso-fdis-22941>

Dimensions in millimetres

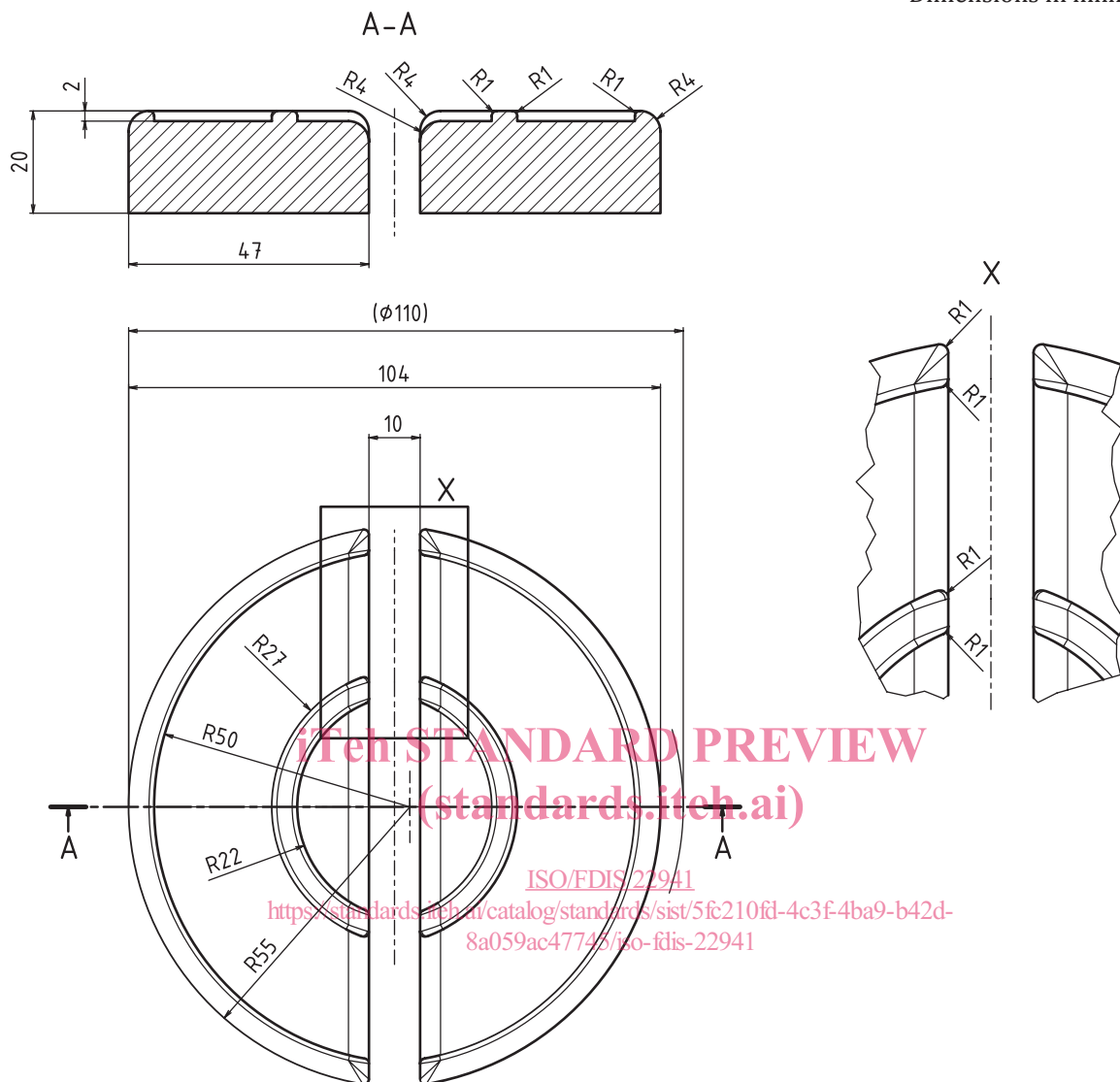

Figure B.1 — Indenter for walking area test