



Designation: ~~C1207-03~~ Designation: C1207 - 10

Standard Test Method for Nondestructive Assay of Plutonium in Scrap and Waste by Passive Neutron Coincidence Counting¹

This standard is issued under the fixed designation C1207; the number immediately following the designation indicates the year of original adoption or, in the case of revision, the year of last revision. A number in parentheses indicates the year of last reapproval. A superscript epsilon (ϵ) indicates an editorial change since the last revision or reapproval.

1. Scope

1.1 This test method describes the nondestructive assay of scrap or waste for plutonium content using passive thermal-neutron coincidence counting. This test method provides rapid results and can be applied to a variety of carefully sorted materials in containers as large as ~~208-L drums, several thousand liters in volume.~~ The test method applies to measurements of ²³⁸Pu, ²⁴⁰Pu, and ²⁴²Pu and has been used to assay items whose total plutonium content ranges from ~~0.01-10 mg to 6000-g~~ **6 kg (1)**.²

1.2 This test method requires knowledge of the relative abundances of the ~~plutonium~~ Pu isotopes to determine the total ~~plutonium mass.~~ Pu mass (Test Method C1030).

1.3 This test method may not be applicable to the assay of scrap or waste containing other spontaneously fissioning nuclides.

1.3.1 This test method may give biased results for measurements of containers that include large amounts of hydrogenous materials.

1.3.2 The techniques described in this test method have been applied to materials other than scrap and waste **(2, 3)**.

1.4 This test method assumes the use of shift-register-based coincidence technology **(4)**.

1.5 Several other techniques that are ~~related to~~ often encountered in association with passive neutron coincidence counting exist. These include neutron multiplicity counting **(5, 6)**, ~~add-a-source analysis~~ **6**, Test Method C1500), ~~add-a-source analysis for matrix correction (7), and cosmic-ray rejection,~~ **flux probes also for matrix compensation, cosmic-ray rejection (8)**. ~~Discussions of these techniques are not included in this method.~~ **to improve precision close to the detection limit, and alternative data collection electronics such as list mode data acquisition. Passive neutron coincidence counting may also be combined with certain active interrogation schemes as in Test Methods C1316 and C1493. Discussions of these established techniques are not included in this method.**

1.6 *This standard does not purport to address all of the safety concerns, if any, associated with its use. It is the responsibility of the user of this standard to establish appropriate safety and health practices and determine the applicability of regulatory limitations prior to use.*

2. Referenced Documents

2.1 *ASTM Standards:*³ ~~C859~~ Terminology Relating to Nuclear Materials

C986 Guide for Developing Training Programs in the Nuclear Fuel Cycle

C1009 Guide for Establishing a Quality Assurance Program for Analytical Chemistry Laboratories Within the Nuclear Industry
E1030

C1030 Test Method for Determination of Plutonium Isotopic Composition by Gamma-Ray Spectrometry

C1068 Guide for Qualification of Measurement Methods by a Laboratory Within the Nuclear Industry

C1128 Guide for Preparation of Working Reference Materials for Use in Analysis of Nuclear Fuel Cycle Materials

C1133 Test Method for Nondestructive Assay of Special Nuclear Material in Low-Density Scrap and Waste by Segmented Passive Gamma-Ray Scanning ~~C1156~~ Guide for Establishing Calibration for a Measurement Method Used to Analyze Nuclear Fuel Cycle Materials

C1210 Guide for Establishing a Measurement System Quality Control Program for Analytical Chemistry Laboratories Within the Nuclear Industry

C1215 Guide for Preparing and Interpreting Precision and Bias Statements in Test Method Standards Used in the Nuclear Industry

¹ This practice is under the jurisdiction of ASTM Committee C26 on Nuclear Fuel Cycle and is the direct responsibility of Subcommittee C26.10 on Nondestructive Assay. Current edition approved Feb. 10, 2003. Published March 2003. Originally approved in 1991. Last previous edition approved in 1997 as C1207-97. DOI: 10.1520/C1207-03 on Non Destructive Assay.

Current edition approved June 1, 2010. Published July 2010. Originally approved in 1991. Last previous edition approved in 2003 as C1207 - 03. DOI: 10.1520/C1207-10.

² The boldface numbers in parentheses refer to the list of references at the end of this test method.

³ For referenced ASTM standards, visit the ASTM website, www.astm.org, or contact ASTM Customer Service at service@astm.org. For *Annual Book of ASTM Standards* volume information, refer to the standard's Document Summary page on the ASTM website.

[C1500 Test Method for Nondestructive Assay of Plutonium by Passive Neutron Multiplicity Counting](#) [1316 Test Method for Nondestructive Assay of Nuclear Material in Scrap and Waste by Passive-Active Neutron Counting Using ²⁵²Cf Shuffler](#)
[C1458 Test Method for Nondestructive Assay of Plutonium, Tritium and ²⁴¹Am by Calorimetric Assay](#)
[C1490 Guide for the Selection, Training and Qualification of Nondestructive Assay \(NDA\) Personnel](#)
[C1493 Test Method for Non-Destructive Assay of Nuclear Material in Waste by Passive and Active Neutron Counting Using a Differential Die-Away System](#)
[C1500 Test Method for Nondestructive Assay of Plutonium by Passive Neutron Multiplicity Counting](#)
[C1592 Guide for Nondestructive Assay Measurements](#)
[C1673 Terminology of C26.10 Nondestructive Assay Methods](#)

2.2 ANSI Standards:⁴

ANSI 15.20 Guide to Calibrating Nondestructive Assay Systems ANSI 15.35 Guide to Preparing Calibration Materials for NDA Systems that Count Passive Gamma-Rays

ANSI 15.36 Nondestructive Assay Measurement Control and Assurance

3. Terminology The following definitions are needed in addition to those presented in ASTM C859:

3.1 Definitions:

3.1.1 *(α, n) reactions*—occur when energetic alpha particles collide with low atomic number nuclei, such as O, F, or Mg, producing single neutrons.

3.1.2 *coincidence Gate Length*—the time interval following the detection of a neutron during which additional neutrons are considered to be in coincidence with the original neutron.

3.1.3 *coincident neutrons*—two or more neutrons emitted simultaneously from a single event, such as from a nucleus during fission.

3.1.4 *Die-away time*—the average life time of the neutron population as measured from the time of emission to detection, escape, or absorption. The average life time is the time required for the neutron population to decrease by a factor of $1/e$. It is a function of several parameters including chamber design, detector design, assay item characteristics, and neutron energy.

3.1.5 *item*—an item refers to the entire scrap or waste container being measured and its contents.

3.1.6 *matrix*—the material which comprises the bulk of the item, except for the special nuclear material and the container. This is the material in which the special nuclear material is embedded.

3.1.6.1 *benign matrix*—a matrix that has negligible effects on neutron transport. A benign matrix includes very little neutron moderator.

3.1.6.2 *matrix-specific calibration*—uses a calibration matrix similar to the matrix to be measured. No matrix correction factors are used. This calibration is generally not appropriate for other matrices.

3.1.7 *neutron absorbers*—materials which have relatively large thermal-neutron absorption cross sections. Absorbers with the largest cross sections are commonly known as neutron poisons. Some examples are lithium, boron, cadmium, and gadolinium.

3.1.8 *neutron moderators*—materials which slow down neutrons. Materials containing large amounts of low atomic weight materials, e.g. hydrogen are highly moderating.

3.1.9 *passive neutron coincidence counting*—a technique used to measure the rate of coincident neutron emission in the assay item. The terminology used in this test method refers specifically to shift-register electronics (9, 10). Fig. 1 shows the probability of detecting a neutron as a function of time and illustrates the time intervals discussed.

3.1.9.1 *Shift-register-based coincidence circuit*—an electronic circuit for determining totals τ , reals plus accidentals ($r + a$), and accidentals (a) in a selected count time t (9, 10). Shift register-based circuitry was developed to reduce dead times in thermal neutron coincidence counters. This technique permits improved measurement precision and operation at higher count rate (≥ 100 kHz).

3.1.9.2 *totals τ* —the total number of neutrons detected during the count time. This is a measured quantity.

3.1.9.3 *reals plus accidentals, ($r + a$)*—the number of neutrons detected in the ($r + a$) gate period (Fig. 1) following the initial detection of each neutron. This is a measured quantity during the count time (4, 9).

3.1.9.4 *accidentals, (a)*—the number of neutrons detected in the (a) gate period (Fig. 1) following the initial detection of each neutron during the selected count time t . This is a measured quantity (4, 9).

3.1.9.5 *Reals, (r)*—This quantity is the difference between the ($r + a$) and (a) quantities (4, 9). It is proportional to the number of fissions in the sample.

3.1.10 *Neutron multiplication*—Multiplication takes place when a neutron interaction yields more than one neutron as a product. Induced fission is the primary mechanism for neutron multiplication, however ($n, 2n$) interactions are also multiplication events.

3.1.11 *Poisson assumption*—For passive neutron coincidence measurements, it is assumed that the net counts in a fixed period of time follow a Poisson distribution. This assumption can be verified by comparing the observed standard deviation of a series of measurements on an item with the square root of the average number of counts. If the Poisson assumption is correct, these numbers should be equal within random error.

⁴ Available from American National Standards Institute (ANSI), 25 W. 43rd St., 4th Floor, New York, NY 10036, <http://www.ansi.org>.

3.1.12 *Precision*—The precision of a measurement is taken to be the standard deviation or (percent) relative standard deviation of a series of measurements taken on the same item under essentially the same conditions.

3.1.13 *Pre-delay*—the coincidence circuit has a pre-delay immediately after a neutron has been detected to allow the amplifiers to recover and prepare to detect subsequent neutrons. This principle is shown in Fig. 1.

²⁴⁰Pu effective mass, m_{eff} —is the mass of ²⁴⁰Pu that would produce the same coincident neutron response in the instrument as the assay item. It is correlated to the quantity of even mass isotopes of plutonium in the assay item ~~(11)~~.

3.1.15 *transuranic waste (TRU waste)*—as defined in DOE Order 5820.2 ~~(12)~~, transuranic waste is radioactive waste containing alpha-emitting isotopes with atomic number greater than 92 and half-life greater than 20 years, and with activity concentrations greater than 100 nCi per gram of waste at the time of the measurement. Terminology

3.1 Refer to Terminology C1673 for definitions used in this test method.

4. Summary of Test Method

4.1 The even mass isotopes of plutonium fission spontaneously. On the average, two or more neutrons are emitted per fission event. The number of these coincident neutrons detected by the instrument is correlated to the quantity of even mass isotopes of plutonium in the assay item, m_{eff} . The total plutonium mass is determined from the known plutonium isotopic ratios and the measured quantity of even mass isotopes.

4.1 The even mass isotopes of Pu fission spontaneously. On the average, two or more prompt neutrons are emitted per fission event. The number of time correlated or coincident neutrons detected by the instrument is related to the effective mass of ²⁴⁰Pu, m_{eff} , present in the time. The effective ²⁴⁰Pu mass is a weighted sum of the even mass isotopes of Pu in the assay item. The total Pu mass is determined from the known plutonium isotopic ratios and the measured quantity m_{eff} .

4.2 The shift register technology is intended to correct for the effects of *accidental neutron coincidences*.

4.3 Other factors which may affect the assay are neutron multiplication and matrix components with large (α , n) reaction rates, neutron absorbers, or moderators. Corrections for these effects are often not possible from the measurement data alone, consequently assay items are sorted into material categories or additional information is used to obtain the best assay result. Accidental neutron coincidences which result from the registration of neutrons in the coincidence gate which are not correlated in time to the neutron which triggered the inspection of the gate.

4.3 Other factors which may affect the assay are neutron self multiplication, matrix components with large (α , n) reaction rates, neutron absorbers, or moderators. Corrections for these effects are often not possible from the measurement data alone, consequently assay items are commonly sorted into material categories or additional information is sometimes used.

4.4 Corrections are typically made for electronic deadtime and neutron background.

4.5 Calibrations are based on measurements of well documented and appropriate reference materials.

4.5 Calibrations are typically based on measurements of well documented and appropriate reference materials. Modeling based on knowledge of the instrument design and the physical principles of neutron interactions may also be applied.

4.6 This method includes measurement control tests to verify reliable and stable performance of the instrument.

5. Significance and Use

5.1 This test method is useful for determining the plutonium content of scrap and waste in containers as large as 208-L (55-gal) drums. Total plutonium content ranges from 10 mg to 6 kg

5.1 This test method is useful for determining the plutonium content of scrap and waste in containers ranging from small cans with volumes of the order of a mL to crates and boxes of several thousand liters in volume. A common application would be to 208-L (55-gal) drums. Total Pu content ranges from 10 mg to 6 kg ~~(1)~~. The upper limit may be restricted to smaller mass values depending on specific matrix, calibration material, criticality safety, or counting equipment considerations.

5.2 This test method is applicable for U.S. Department of Energy shipper/receiver confirmatory measurements ~~(13)(9)~~, nuclear material diversion detection, and International Atomic Energy Agency attributes measurements ~~(14)(10)~~.

5.3 This test method should be used in conjunction with a scrap and waste management plan that segregates scrap and waste assay items into material categories according to some or all of the following criteria: bulk density, the chemical forms of the plutonium and the matrix, americium to plutonium isotopic ratio, and hydrogen content. Packaging for each category should be uniform with respect to size, shape, and composition of the container. Each material category ~~with~~ might require calibration standards and may have different ~~plutonium~~ Pu mass limits.

5.4 Bias in passive neutron coincidence measurements is related to item size and density, the homogeneity and composition of the matrix, and the quantity and distribution of the nuclear material. The precision of the measurement results is related to the quantity of nuclear material, the (α ,n) reaction rate, and the count time of the measurement.

5.4.1 For both benign matrix and matrix specific measurements, the method assumes the calibration reference materials match the items to be measured with respect to the homogeneity and composition of the matrix, the neutron moderator and absorber content, and the quantity of nuclear material, to the extent they affect the measurement.

5.4.2 Measurements of smaller containers containing scrap and waste are generally more accurate than measurements of 208-L (55-gal) drums. larger items.

5.4.3 It is recommended that where feasible measurements be made on items with homogeneous contents. Heterogeneity in the distribution of nuclear material, neutron moderators, and neutron absorbers have the potential to cause biased results.

5.5 The coincident neutron production rates measured by this test method are proportional related to the mass of the even number isotopes of plutonium. If the relative abundances of these isotopes are not accurately known, biases in the total plutonium Pu assay value will result.

5.6 Typical count time is 1000 seconds. Typical count times are in the range of 300 to 3600 s.

5.7 Reliable results from the application of this method require training of the personnel who package the scrap and waste prior to measurement and of personnel who perform the measurements. Training guidance is available from ANSI 15.20, ASTM C1009, ASTM Guides C986, and ASTM, C1009, C1068, and C1490.

6. Interferences

6.1 Conditions affecting measurement uncertainty include neutron background, moderators, multiplication, large (α, n) rates, absorbers, matrix and nuclear material heterogeneity, and other sources of coincident neutrons. It is usually not possible to detect these problems or to calculate corrections for these effects from the measurement data alone. Consequently, assay items are sorted into material categories defined on the basis of these effects.

6.2 Neutron background levels from external sources should be kept as low and as constant as practical. Corrections can be made for the effects of high-neutron background levels, but these will adversely affect measurement precision and detection limits.

6.3 Neutron moderation by low atomic mass materials will not only increase thermal-neutron absorption effects, but will also increase multiplication effects. Consequently, the measured neutron rates may be either smaller or larger than those for a nonmoderating matrix. Hydrogenous matrices contribute the most to this effect.

6.4 Both spontaneous and induced fissions produce coincident neutrons. The instrument, however, cannot distinguish between them. Three factors that strongly affect the degree of multiplication are the mass of fissile material, its density, and its geometry. Increases in mass that are not accompanied by changes in either density or geometry will result in predictable multiplication increases that can be incorporated into the calibration function. Localized increases in nuclear material density and/or changes in the geometry are likely to cause unknown changes in multiplication and measurement bias.

6.5 Neutrons from (α, n) reactions are an interference source if they induce multiplication effects. In addition, (α, n) neutrons can increase the Accidentals rate thereby affecting the statistical precision of the assay which is based on the coincidence rate.

6.6 Biases may result from non-uniformity in the source distribution and heterogeneity in the matrix distribution.

6.7 Other spontaneous fission nuclides (for example, curium or californium) will increase the coincident neutron count rates, causing an overestimation of the plutonium content.

6.8 Cosmic rays, which are difficult to shield against, can produce coincident neutrons. Cosmic ray effects become larger for small quantities of plutonium Pu in the presence of large quantities of relatively high atomic number materials, for example, iron or lead are more prolific producers than cellulosic wastes (see 12.5).

7. Apparatus

7.1 Counting Assembly—See Fig. 2 Fig. 1.

7.1.1 The apparatus used in this test method can be obtained commercially. Specific applications may require customized design. The neutron detectors are usually ³He proportional counters embedded in polyethylene. The detection efficiency for neutrons of fission energy should be at least 15%. Larger detection efficiencies provide better precision and lower detection limits for a given count time. Ideally, the counter detection efficiency should vary less than 10% over the item volume.

7.1.2 Reproducible positioning of the item in the chamber is important for obtaining the best accuracy. This counting geometry should be maintained for the measurement of all reference materials and assay items. (See He proportional counters embedded in

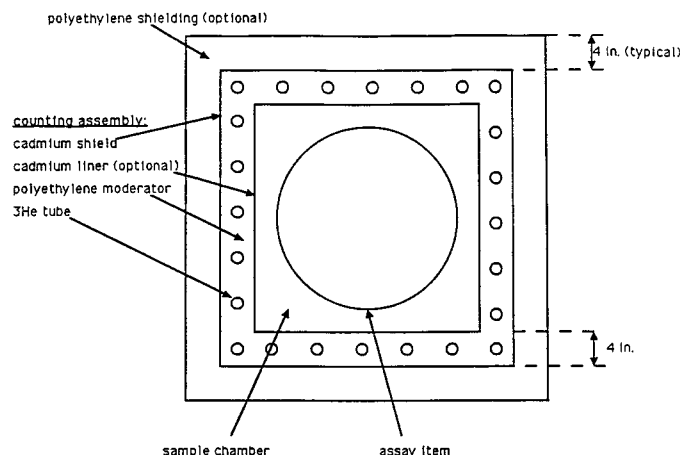

FIG.-2 1 A Cross-section View of a Typical Thermal-Neutron Coincidence Counter

polyethylene. The detection efficiency for neutrons of fission energy is typically at least 15 %. Larger detection efficiencies provide better precision and lower detection limits for a given count time. A short dieaway time is also important in that it allows a shorter gate width to be used which in turn helps control the Accidents. Ideally, the counter detection efficiency should vary less than 10 % over the item volume. The coincident response varies as the square of the detection efficiency.

7.1.2 Reproducible positioning of the item in the assay chamber is important for obtaining the best accuracy. This counting geometry should be maintained for the measurement of all reference materials and assay items. (See 11.7.)

7.1.3 A 0.4 mm to 1mm thick cadmium liner (~~16~~(12)) is often installed on the inside surfaces of the counting chamber surrounding the assay item. This liner will reduce the dieaway time, decrease multiplication inside the item from returning neutrons and decrease the effects on the assay of neutron absorbers inside the item. The liner will also decrease neutron detection efficiency due to absorption of thermalized neutrons and may increase the cosmic ray spallation background. The final design may represent a compromise between multiple conflicting influences.

7.2 *Shielding*—The detector assembly is often surrounded by cadmium and an additional layer of hydrogenous material (see Fig. 21). ~~Four inches~~ Approximately 100 mm of polyethylene can reduce the neutron background in the ~~sample~~ assay chamber by approximately a factor of 10 (~~17~~13).

7.3 *Electronics*—High-count-rate nuclear electronics provide a standard logic pulse from the ³He proportional counters. These pulses are processed by the shift-register coincidence technology.

7.4 Data acquisition and reduction can be facilitated by interfacing the instrument to a computer.

8. Hazards

8.1 *Safety Hazards*—Consult qualified professionals as needed.

8.1.1 Precautions should be taken to prevent inhalation, ingestion, or the spread of plutonium Pu contamination during waste or scrap handling operations. All containers should be surveyed on a regular basis with an appropriate monitoring device to verify their continued integrity.

8.1.2 Precautions should be taken to minimize personnel exposure to radiation.

8.1.3 Precautions should be taken regarding nuclear criticality, especially of unknown items. The measurement chamber approximates a reflecting geometry for fast neutrons. The assumption that waste is not of criticality concern is not recommended.

8.1.4 Counting chambers may contain a cadmium liner. Precautions should be taken to prevent the inhalation or ingestion of cadmium. It is a heavy metal poison. Cadmium shielding should be covered with nontoxic materials.

8.1.5 Precautions should be taken to avoid contact with high voltage. The ³He tubes proportional counters require low current, high voltage, power supplies.

8.1.6 The weight of the instrument may exceed facility floor loading capacities. Check for adequate floor loading capacity before installation.

8.2 *Technical Hazards*:

8.2.1 Locate the instrument in an area of low-neutron background. Prohibit the movement of radioactive material in the vicinity of the instrument while a measurement is in progress.

8.2.2 Utilizing a measurement result outside of the calibration range should be carefully evaluated and, in general, is not recommended.

8.2.3 Utilizing a measurement result based on a calibration for a different material category should be carefully evaluated and, in general, is not recommended.

9. Instrument Preparation and Calibration

NOTE 1—Instrument preparation, determination of material categories, and calibration of passive neutron coincidence counters is discussed in the section below. Many details of these operations are site specific, depend on the matrix categories and nuclear materials to be measured, and should be evaluated by subject matter experts. Additional sources of information are ASTM Guide C1009C1592, C1068, C1128, C1156, C1210, and C1215; ANSI 15.20, 15.35, and 15.36.

9.1 *Initial Preparation of Apparatus*:

9.1.1 Locate the instrument in an area with the lowest practical neutron background. Prohibit the movement of radioactive material in the vicinity of the instrument while a measurement is in progress.

9.1.2 Perform the initial setup recommended by the system manufacturer in consultation with subject matter experts.

9.1.3 If the high-voltage plateau, die-away time, and dead-time correction coefficients were not supplied by the manufacturer, determine them. Consult an appropriate text on radiation detectors (1814) or the manufacturer if assistance is needed.

9.1.4 If it is a user adjustable feature, set the gate length. The optimum gate length for a wide range of count rates is 1.257 times the die-away time (~~19~~or the manufacturer if assistance is needed and involve subject matter experts. Repeating these determinations can be a powerful check on the operational health of the instrument.

9.1.4 Set the gate length if it is a user adjustable feature. The optimum gate length for a wide range of count rates is about 1.257 times the die-away time (15). Low count rate applications sometimes benefit from longer gate lengths Changingchanging the gate length alters all calibrations. Whenever the gate length is changed, the instrument must be recalibrated.

~~9.1.5~~ If it is a user adjustable feature, place 9.1.5 Place the necessary cadmium liners in the assay chamber if it is a user

adjustable feature. Very low gram quantity applications benefit from having no cadmium liner. Separate calibrations are required for each cadmium liner configuration.

9.1.6 Use a stable neutron source and refer to vendor's manuals to verify that the electronics are stable and operating properly.

9.1.6.1 Place a source of coincident neutrons, for example, ^{252}Cf with an emission rate of $\sim 4\sim 5 \times 10^4$ neutrons/s, n.s.⁻¹, in the center of the counting chamber. Determine the Totals (T), reals (r), Reals (R), and Accidentals (A) neutron count rates from the measured quantities:

$$(1) \quad A = at,$$

$$A_{calc} = T^2 \times \text{gate length}, \quad (2)$$

$$(3) \quad R = [(r+a) - a]t$$

where:

$$T = \text{totals rate} = \tau/t. \quad (4)$$

~~A necessary but not sufficient indication of proper electronics operation is agreement between A_{calc} and r neutron count rates from the accumulated quantities divided by the count time. A necessary but not sufficient indication of proper electronics operation is agreement between A within counting statistics. This test is termed the Accidentals/Totals test, and the calculated quantity (calculated from the product of the square of the Totals rate and the gate width) within counting statistics or a predefined threshold.~~

9.1.6.2 Leaving the ^{252}Cf neutron source inside the assay chamber, place a source of random neutrons, for example, americium-lithium with an emission rate of $\sim 4\sim 5 \times 10^4$ neutrons/s, n.s.⁻¹, in, or near, the counting chamber. Determine the reals Reals rates from the measured quantities for ^{252}Cf with and without the random neutron source. The reals Reals rates should agree to within counting statistics for the two measurements (see 11.1).

9.1.6.3 Use these measurements as part of the measurement control data described in 10.1.

9.2 Determination of Material Categories for Required Calibrations:

9.2.1 Use this test method in conjunction with a scrap and waste management plan that segregates scrap and waste materials into categories with respect to the characteristics discussed in 5.3, and Sections 6 and 12. Packaging for each category defined ~~must~~ should be uniform. Each material category will require a set of representative reference materials.

9.2.2 The material categories are normally one of three classifications: oxide, metal, or salt.

9.2.3 The effectiveness of the scrap and waste management plan and the validity of the resulting calibrations are best evaluated by the R/T ratio check described in Appendix X1.

9.3 Preparation and Characterization of Reference Materials Preparation and Characterization of Reference Materials (Guide C1128):

~~9.3.1~~ 9.3.1 Reference materials 9.3.1 Calibration items should be as similar as possible to the assay items with respect to parameters such as size, shape, and composition which affect the measurement (see 5.3).

9.3.1.1 The plutonium Pu mass loadings should ideally span the range of loadings expected in the assay items and be adequate to define the shape of the calibration curve. Three to eight mass loadings are deemed suitable for each material category. ()

9.3.1.2 The ~~reals-to-totals~~ Reals-to-Totals ratio, (R/T), may be used as an indicator to determine whether the neutron emission characteristics of the measured item matches the reference materials. Reasonable agreement between the R/T ratios for the reference materials and assay items (defined by a facility-dependent evaluation for each material category) suggests that the reference material is appropriate. See Appendix X1 for more information.

9.3.2 For waste measurements of small gram quantities of plutonium, dilute the plutonium used in the reference materials sufficiently to eliminate multiplication effects.

~~9.3.3~~ 9.3.3 Certify 9.3.3 The accuracy of the ~~reference materials~~ calibration items should be established; ideally by a technique that has significantly smaller measurement uncertainty than that desired for the coincidence counter results.

9.3.4 Permanently record the following information for each ~~reference material~~ calibration item: packaging material(s), matrix, plutonium mass, m_{eff} , plutonium isotopic composition, and americium content with the date(s) measured.

9.4 Calibration Procedure—Use the following calibration procedure for each material category.

9.4.1 Calibration of a neutron coincidence counting instrument determines the relationship between the ~~reals~~ Reals count rate (R) and the ^{240}Pu effective mass, m_{eff} .

9.4.2 Measure each ~~reference material~~ calibration item such that the measurement precision is substantially (for example, 3 to 5 times) better than that expected for assay items of similar plutonium Pu mass. See Section 10.2 for counting procedures and Section 11 for required calculations.

9.4.3 Choice of calibration functions will depend on the characteristics of the material category as indicated below.

9.4.3.1 Measurements of small quantities of plutonium Pu that exhibit no multiplication will normally show a linear relation of the form:

$$R = a_0 + a_1 m_{eff} \quad (1)$$

where a_1 and a_0 are coefficients determined by the fitting procedure.

9.4.3.2 Measurements of large quantities of plutonium Pu of consistent chemical form and item geometry, will normally often show a calibration function of the form: