



Designation: C1472 – 10

## Standard Guide for Calculating Movement and Other Effects When Establishing Sealant Joint Width<sup>1</sup>

This standard is issued under the fixed designation C1472; the number immediately following the designation indicates the year of original adoption or, in the case of revision, the year of last revision. A number in parentheses indicates the year of last reapproval. A superscript epsilon ( $\epsilon$ ) indicates an editorial change since the last revision or reapproval.

### 1. Scope

1.1 This guide provides information on performance factors such as movement, construction tolerances, and other effects that should be accounted for to properly establish sealant joint size. It also provides procedures to assist in calculating and determining the required width of a sealant joint enabling it to respond properly to those movements and effects. Information in this guide is primarily applicable to single- and multi-component, cold-applied joint sealants and secondarily to precured sealant extrusions when used with properly prepared joint openings and substrate surfaces.

1.2 Although primarily directed towards the understanding and design of sealant joints for walls for buildings and other areas, the information contained herein is also applicable to sealant joints that occur in horizontal slabs and paving systems as well as various sloped building surfaces.

1.3 This guide does not describe the selection and properties of joint sealants (**1**)<sup>2</sup>, nor their use and installation, which is described by Guide C1193.

1.4 For protective glazing systems that are designed to resist blast and other effects refer to Guide C1564 in combination with this guide.

1.5 This guide is not applicable to the design of joints sealed with aerosol foam sealants.

1.6 For structural sealant glazing systems refer to Guide C1401 in combination with this guide.

1.7 The values and calculations stated in SI units are to be regarded as the standard. The values given in parentheses and inch-pound units are provided for information only. SI units in this guide are in conformance with IEEE/ASTM SI 10-1997.

1.8 The Committee having jurisdiction for this guide is not aware of any comparable standards published by other organizations.

<sup>1</sup> This guide is under the jurisdiction of ASTM Committee C24 on Building Seals and Sealants and is the direct responsibility of Subcommittee C24.10 on Specifications, Guides and Practices.

Current edition approved June 1, 2010. Published June 2010. Originally approved in 2000. Last previous edition approved in 2006 as C1472 – 06. DOI: 10.1520/C1472-10.

<sup>2</sup> The boldface numbers in parentheses refer to the list of references at the end of this standard.

1.9 *This standard does not purport to address all of the safety concerns, if any, associated with its use. It is the responsibility of the user of this standard to establish appropriate safety and health practices and determine the applicability of regulatory limitations prior to use.*

### 2. Referenced Documents

#### 2.1 ASTM Standards:<sup>3</sup>

C216 Specification for Facing Brick (Solid Masonry Units Made from Clay or Shale)

C717 Terminology of Building Seals and Sealants

C719 Test Method for Adhesion and Cohesion of Elastomeric Joint Sealants Under Cyclic Movement (Hockman Cycle)

C794 Test Method for Adhesion-in-Peel of Elastomeric Joint Sealants

C920 Specification for Elastomeric Joint Sealants

C1193 Guide for Use of Joint Sealants

C1401 Guide for Structural Sealant Glazing

C1481 Guide for Use of Joint Sealants with Exterior Insulation and Finish Systems (EIFS)

C1518 Specification for Precured Elastomeric Silicone Joint Sealants

C1523 Test Method for Determining Modulus, Tear and Adhesion Properties of Precured Elastomeric Joint Sealants

C1564 Guide for Use of Silicone Sealants for Protective Glazing Systems

#### 2.2 American Concrete Institute (ACI), American Society of Civil Engineers (ASCE), and The Masonry Society (TMS):<sup>4</sup>

Building Code Requirements for Masonry Structures (ACI 530-02/ASCE 5-02/TMS 401-02) Reported by the Masonry Standards Joint Committee (MSJC)

<sup>3</sup> For referenced ASTM standards, visit the ASTM website, www.astm.org, or contact ASTM Customer Service at service@astm.org. For *Annual Book of ASTM Standards* volume information, refer to the standard's Document Summary page on the ASTM website.

<sup>4</sup> Available from American Concrete Institute (ACI), P.O. Box 9094, Farmington Hills, MI 48333, American Society of Civil Engineers (ASCE), 1801 Alexander Bell Dr., Reston, VA 20191 and The Masonry Society, 3970 Broadway, Suite 201-D, Boulder, CO 80304-1135.

2.3 *Prestressed Concrete Institute (PCI):*<sup>5</sup>

**Manual for Quality Control for Plants and Production of Architectural Precast Concrete Products, MNL-177-77**

2.4 *American Society of Heating, Refrigerating and Air-Conditioning Engineers, Inc. (ASHRAE):*<sup>6</sup>

**Chapter 27, Climatic Design Information, Tables 1A, 1B, 2A, 2B, 3A, 3B, ASHRAE 2002 Fundamentals Handbook**

2.5 *Brick Industry Association (BIA):*<sup>7</sup>

**Volume Changes, and Effects of Movement, Part I, Technical Notes on Brick Construction, No. 18, Reissued Sept. 2000**

2.6 *Institute of Electrical and Electronics Engineers, Inc. (IEEE) and ASTM:*<sup>3</sup>

**IEEE/ASTM SI 10-2002 Standard for Use of the International System of Units (SI): The Modern Metric System**

### 3. Terminology

#### 3.1 Definitions:

3.1.1 Refer to Terminology **C717** for definitions of the terms used in this guide.

#### 3.2 Definitions of Terms Specific to This Standard:

3.2.1 *coefficient of linear thermal movement*—an increase or decrease in unit length per unit change in material temperature of a material or assembly of materials.

3.2.2 *coefficient of solar absorption*—a factor describing the capability of a material or assembly of materials to absorb a percentage of incident solar radiation.

3.2.3 *heat capacity constant*—a factor describing the capability of a material or assembly of materials to store heat generated by absorbed solar radiation.

#### 3.3 Symbols:

$\alpha$	=	Coefficient of linear thermal movement
$\alpha_B$	=	Coefficient of linear thermal movement for brick
$\alpha_X$	=	Coefficient of linear thermal movement for a particular material
$A$	=	Coefficient of solar absorption
$A_B$	=	Coefficient of solar absorption for brick
$A_X$	=	Coefficient of solar absorption for a particular material
$B$	=	Sealant backing length
$C$	=	Compression
$C_B$	=	Construction tolerance for brick masonry
$C_X$	=	Construction tolerance for a particular material or system
$E$	=	Extension
$E_L$	=	Longitudinal extension
$E_T$	=	Transverse extension
$E_X$	=	Longitudinal or transverse movement for a particular condition
$H$	=	Heat capacity constant

$H_X$	=	Heat capacity constant for a particular material
$I$	=	Moisture-induced irreversible growth
$L$	=	Unrestrained length or sealant joint spacing
$\Delta L_B$	=	Dimensional change due to brick thermal movement
$\Delta L_C$	=	Dimensional change due to compression
$\Delta L_E$	=	Dimensional change due to extension
$\Delta L_I$	=	Dimensional change due to irreversible moisture movement
$\Delta L_L$	=	Dimensional change due to longitudinal extension
$\Delta L_P$	=	Dimensional change due to precast concrete thermal movement
$\Delta L_R$	=	Dimensional change due to reversible moisture movement
$\Delta L_T$	=	Dimensional change due to transverse extension
$\Delta L_X$	=	Dimensional change for a particular condition
$R$	=	Moisture induced reversible growth
$S$	=	Sealant movement capacity
$T_A$	=	Hottest summer air temperature
$T_{IS}$	=	Maximum summer installation wall surface temperature
$T_{IW}$	=	Minimum winter installation wall surface temperature
$T_S$	=	Hottest summer wall surface temperature
$T_W$	=	Coldest winter wall surface temperature
$\Delta T_M$	=	Maximum expected temperature difference
$\Delta T_S$	=	Summer installation temperature difference
$\Delta T_W$	=	Winter installation temperature difference
$\Delta T_X$	=	Temperature difference for a particular condition
$W$	=	Final designed sealant joint width
$W_M$	=	Sealant joint width required for movement
$W_R$	=	Sealant joint width at rest prior to movement

### 4. Significance and Use

4.1 Design professionals, for aesthetic reasons, have desired to limit the spacing and width of sealant joints on exterior walls and other locations of new buildings. Analysis of the performance factors and especially tolerances that affect a sealant joint is necessary to determine if a joint will have durability and be effective in maintaining a seal against the passage of air and water and not experience premature deterioration. If performance factors and tolerances are not understood and included in the design of a sealant joint, then the sealant may reach its durability limit and failure is a distinct possibility.

4.2 Sealant joint failure can result in increased building energy usage due to air infiltration or exfiltration, water infiltration, and deterioration of building systems and materials. Infiltrating water can cause spalling of porous and friable building materials such as concrete, brick, and stone; corrosion of ferrous metals; and decomposition of organic materials, among other effects. Personal injury can result from a fall incurred due to a wetted interior surface as a result of a failed sealant joint. Building indoor air quality can be affected due to organic growth in concealed and damp areas. Deterioration is often difficult and very costly to repair, with the cost of repair work usually greatly exceeding the original cost of the sealant joint work.

4.3 This guide is applicable to sealants with an established movement capacity, in particular elastomeric sealants that meet Specification **C920** with a minimum movement capacity rating

<sup>5</sup> Available from the Prestressed Concrete Institute (PCI), 209 W. Jackson Blvd. #500, Chicago, IL 60606.

<sup>6</sup> Available from American Society of Heating, Refrigerating, and Air-Conditioning Engineers, Inc. (ASHRAE), 1791 Tullie Circle, NE, Atlanta, GA 30329.

<sup>7</sup> Available from Brick Industry Association (BIA), formerly Brick Institute of America, 11490 Commerce Park Dr., Reston, VA 20191-1525.

of  $\pm 12\frac{1}{2}$  percent. In general, a sealant with less than  $\pm 12\frac{1}{2}$  percent movement capacity can be used with the joint width sizing calculations; however, the width of a joint using such a sealant will generally become too large to be practically considered and installed. It is also applicable to precured sealant extrusions with an established movement capacity that meets Specification **C1518**.

4.4 The intent of this guide is to describe some of the performance factors and tolerances that are normally considered in sealant joint design. Equations and sample calculations are provided to assist the user of this guide in determining the required width and depth for single and multi-component, liquid-applied sealants when installed in properly prepared joint openings. The user of this guide should be aware that the single largest factor contributing to non-performance of sealant joints that have been designed for movement is poor workmanship. This results in improper installation of sealant and sealant joint components. The success of the methodology described by this guide is predicted on achieving adequate workmanship.

4.5 Joints for new construction can be designed by the recommendations in this guide as well as joints that have reached the end of their service life and need routine maintenance or joints that require remedial work for a failure to perform. Guide **C1193** should also be consulted when designing sealant joints. Failure to install a sealant and its components following its guidelines can and frequently will result in failure of a joint design.

4.6 Peer reviewed papers, published in various ASTM Special Technical Publications (STP), provide additional information and examples of sealant joint width calculations that expand on the information described in this guide (2-5). For cases in which the state of the art is such that criteria for a particular condition is not firmly established or there are numerous variables that require consideration, a reference section is provided for further consideration.

4.7 To assist the user of this guide in locating specific information, a detailed listing of guide numbered sections and their headings is included in **Appendix X1**.

## 5. Performance Factors

5.1 *General*—Proper sealant joint design can not be adequately performed without a knowledge and understanding of factors that can affect sealant performance. The following describes most of the commonly encountered performance factors that are known to influence sealant joint design. These performance factors can act individually or, as is mostly the case, in various combinations depending on the characteristics of a particular joint design.

5.2 *Material and System Anchorage*—The type and location of various wall anchors has an impact on the performance of a sealant joint (6). Large precast concrete panels with fixed and moving anchors, brick masonry support system deflection between supports (3), and metal and glass curtain wall fixed and moving anchorages are examples of anchorage conditions that must be considered and evaluated when designing sealant joints for movement. Anchor types and their locations have an effect on determining the effective length of wall material or

support system deflection characteristics that need to be included when designing for sealant joint width.

5.3 *Thermal Movement*—Walls of buildings respond to ambient temperature change, solar radiation, black-body radiation, wetting and drying effects from precipitation, and varying cloud cover by either increasing or decreasing in volume and therefore in linear dimension. The dimensional change of wall materials causes a change in the width of a sealant joint opening, producing a movement in an installed sealant. Thermal movement is the predominate effect causing dimensional change.

5.3.1 Depending on when a sealant is installed, thermal movement may need to be evaluated at different stages in a building's life; for example, expected temperature differentials may need to be considered for the building when it is: 1) under construction, 2) unoccupied and unconditioned, and 3) occupied and conditioned. Each of these stages will have different interior environmental conditions, and depending on the building enclosure material or system being analyzed for movement, one of those stages may produce the maximum expected thermal movement. The required joint opening width, depending on construction procedures and material or wall system types, could be established during one of those stages.

5.3.2 Determining realistic material or wall surface temperatures to establish the expected degree of thermal movement can be challenging. The ASHRAE Fundamentals Handbook, Chapter 14 Appendix Climatic Design Information, lists winter and summer design dry bulb air temperatures for many cities. These listed values can be used to assist in calculating expected surface temperatures for use in joint width calculations. For convenience, dry bulb air temperatures for selected North American locations have been included in **Table 1** and for other World locations in **Table 2**.

5.4 *Thermal Movement Environmental Influences*—The effect of a sudden rain shower or the clouding over of the sky may also have to be considered (6). Both of these events can cause a wall material to change in temperature and therefore dimension. Moisture wetting a warm wall surface cools it and clouds preventing solar warming of the surface produce a similar effect. These effects, depending on the wall system or material, its solar absorptivity, and color, can cause either a time lag and slow rate of movement in a sealant joint for a concrete panel or masonry system, or an almost immediate and fairly rapid rate of movement for a sealant joint in a lightweight, insulated, metal and glass curtain wall.

5.5 *Coefficient of Linear Thermal Movement*—In addition to the temperature extremes a wall material will experience, its coefficient of linear thermal movement ( $\alpha$ ) must also be determined. **Table 3** lists average coefficients of linear thermal movement for some of the commonly used construction materials. For most applications, it is acceptable to use the values for the materials listed in **Table 3**. For some materials and applications, the relationship between temperature and linear dimension, over the expected temperature exposure range, may not be truly linear for the entire range. For a sensitive application, it may be necessary to determine the actual linear dimensional response of a material for discrete

**TABLE 1 Dry Bulb Air Temperatures  $T_W$  and  $T_A$  for Selected North American Locations**  
 Temperatures indicated in degrees Celsius (°C) and degrees Fahrenheit (°F)

Location	Winter		Summer		Location	Winter		Summer	
	99.6 % Value		0.4 % Value			99.6 % Value		0.4 % Value	
	°C	°F	°C	°F		°C	°F	°C	°F
Birmingham, AL	-8	18	34	94	Albuquerque, NM	-11	13	36	96
Mobile, AL	-3	26	34	94	Gallup, NM	-18	-1	32	89
Anchorage, AK	-26	-14	22	71	Albany, NY	-22	-7	32	90
Fairbanks, AK	-44	-47	27	81	New York, NY	-11	13	33	92
Flagstaff, AZ	-17	1	29	85	Raleigh/Durham, NC	-9	16	34	93
Phoenix, AZ	1	34	43	110	Grand Forks, ND	-29	-20	33	91
Fayetteville, AR	-14	6	35	95	Columbus, OH	-17	1	32	90
Little Rock, AR	-9	16	36	97	Oklahoma City, OK	-13	9	37	99
Los Angeles, CA	6	43	29	85	Portland, OR	-6	22	32	90
San Francisco, CA	3	37	28	83	Harrisburg, PA	-13	9	33	92
Denver, CO	-19	-3	34	93	Providence, RI	-15	5	32	89
Hartford, CT	-17	2	33	91	Charleston, SC	-4	25	34	94
Wilmington, DE	-12	10	33	91	Rapid City, SD	-24	-11	35	95
Miami, FL	8	46	33	91	Nashville, TN	-12	10	34	94
Tallahassee, FL	-4	25	35	95	Dallas/Fort Worth, TX	-8	17	38	100
Atlanta, GA	-8	18	34	93	Houston, TX	-2	29	34	94
Honolulu, HI	16	61	32	89	Salt Lake City, UT	-14	6	36	96
Boise, ID	-17	2	36	96	Burlington, VT	-24	-11	31	87
Idaho Falls, ID	-24	-12	33	92	Richmond, VA	-10	14	34	94
Chicago, IL	-21	-6	33	91	Seattle, WA	-5	23	29	85
Rockford, IL	-23	-10	33	91	Spokane, WA	-17	1	33	92
Indianapolis, IN	-19	-3	33	91	Huntington, WV	-14	6	33	91
Des Moines, IA	-23	-9	34	93	Madison, WI	-24	-11	32	90
Sioux City, IA	-24	-11	34	94	Wausau, WI	-26	-15	31	88
Wichita, KS	-17	2	38	100	Casper, WY	-25	-13	33	92
Louisville, KY	-14	6	34	93	Cheyenne, WY	-22	-7	31	87
New Orleans, LA	-1	30	34	93	Edmonton, Alberta	-33	-28	28	82
Caribou, ME	-26	-14	29	85	Vancouver, BC	-8	18	24	76
Portland, ME	-19	-3	30	86	Winnipeg, Manitoba	-33	-27	31	87
Baltimore, MD	-12	11	34	93	Saint John, NB	-23	-9	26	78
Boston, MA	-14	7	33	91	Gander, NF	-20	-4	26	79
Detroit, MI	-18	0	32	90	Cape Perry, NWT	-37	-34	14	58
Marquette, MI	-25	-13	29	85	Halifax, NS	-19	-2	27	80
International Falls, MN	-34	-29	30	86	Toronto, Ontario	-20	-4	31	87
Minneapolis-St. Paul, MN	-27	-16	33	91	Charlottetown, PEI	-21	-6	26	79
Jackson, MS	-6	21	35	95	Montreal, Quebec	-24	-12	29	85
Kansas City, MO	-18	-1	36	96	Regina, Saskatchewan	-34	-29	32	89
Billings, MT	-25	-13	34	93	Whitehorse, YT	-37	-34	25	77
Omaha, NE	-22	-7	35	95					
Ely, NV	-21	-6	32	89					
Las Vegas, NV	-3	27	42	108	Acapulco	20	68	33	92
Concord, NH	-22	-8	32	90	Mexico City	4	39	29	84
Newark, NJ	-12	10	34	93	Veracruz	14	57	34	94

Table 1 data has been extracted from the 2002 ASHRAE Fundamentals Handbook, Chapter 14 Appendix. Section 7.2 illustrates use of the data.

segments of its service temperature range. This may result in different linear coefficients for those segments of the service temperature range. These values would then be used in the calculations to determine sealant joint width. Additionally, absorbed moisture can also affect the thermal movement coefficient of a porous material. The coefficient of thermal movement of a saturated material can be as high as twice that of the dry material. This effect is different from the moisture-induced movement effect described in 5.6. Lastly, for a wall or panel system construction that is a composite of materials, an appropriate coefficient of linear thermal movement should be determined for the composite assembly.

**5.6 Moisture Induced Growth**—Some materials respond to changes in their water or water vapor content by increasing in dimension when water content is high and decreasing in dimension when water content is low. This effect can be reversible or irreversible (7). Materials susceptible to a reversible effect are generally porous and include wood, some natural building stones, concrete, face brick, and concrete block. Some

materials are susceptible to an irreversible change in dimension with the passage of time. For example, a fired clay product, such as a brick, will slowly increase in size, following its firing in a kiln, as its moisture content increases while equilibrating with the environment. Predicting the moisture-induced growth of fired clay products is difficult since there are no standard tests.

5.6.1 Table 4 provides values (as a percent dimensional change) for moisture induced reversible growth (R) as well as irreversible growth (I) for various types of materials (8). In general, cement-based products decrease in dimension and fired clay products increase in dimension irreversibly as they equilibrate with the environment. Reversible growth is based on the likely extremes of in-service moisture content and irreversible growth on the period from material manufacture to its maturity. The use of steel reinforcement will usually lessen the Table 4 concrete values. For clay masonry in Table 4, the ACI 530.1-88/ASCE 6-88 and BIA Technical Notes on Brick Construction No. 18 recommended value of 0.03 can be used



**TABLE 2 Dry Bulb Air Temperatures  $T_W$  and  $T_A$  for Selected World Locations**  
 Temperatures indicated in degrees Celsius (°C) and degrees Fahrenheit (°F)

Location	Winter		Summer		Location	Winter		Summer	
	99.6 % Value		0.4 % Value			99.6 % Value		0.4 % Value	
	°C	°F	°C	°F		°C	°F	°C	°F
Algeria, Algiers	2.0	36	35.2	95	Libya, Tripoli	4.1	39	41.4	107
Argentina, Buenos Aires	-0.7	31	33.9	93	Lithuania, Vilnius	-20.4	-5	27.1	81
Armenia, Yerevan	-14.1	7	35.6	96	Macedonia, Skopje	-12.4	10	35.2	95
Australia, Alice Springs	1.0	34	40.0	104	Malaysia, Kuala Lumpur	21.6	71	34.2	94
Australia, Sydney	5.8	42	32.2	90	Moldova, Chisinau	-14.2	6	30.2	86
Austria, Vienna	-11.1	12	30.1	86	Mongolia, Ulaanbataar	-30.3	-23	27.6	82
Bahamas, Nassau	14.1	57	33.0	91	Morocco, Casablanca	5.7	42	29.6	85
Bahrain, Al-Manamah	11.0	52	39.2	103	Netherlands, Amsterdam	-8.3	17	26.6	80
Belarus, Minsk	-20.7	-5	27.3	81	New Zealand, Auckland	1.8	35	25.2	77
Belgium, Antwerp	-8.7	16	28.0	82	Norway, Oslo	-18.0	0	26.5	80
Bolivia, La Paz	-4.0	25	17.3	63	Oman, Masgat	16.1	61	43.0	109
Brazil, Rio De Janeiro	14.9	59	38.9	102	Panama, Panama	22.8	73	34.8	95
Brazil, San Paulo	8.8	48	31.9	89	Paraguay, Asuncion	4.9	41	36.5	98
Bulgaria, Sofia	-12.1	10	31.3	88	Peru, Lima	13.9	57	29.9	86
Chile, Santiago	-1.4	29	31.9	89	Philippines, Manila	20.4	69	35.0	95
China, Beijing	-10.4	13	34.2	94	Poland, Warsaw	-17.5	0	29.0	84
China, Shanghai	-3.1	26	34.4	94	Portugal, Lisbon	4.0	39	34.1	93
China, Shenyang	-21.0	-6	31.1	88	Puerto Rico, San Juan	20.3	69	33.2	92
Colombia, Bogota	2.2	36	21.1	70	Qatar, Ad Dawhah	10.3	51	43.0	109
Croatia, Zagreb	-13.2	8	31.1	88	Romania, Bucharest	-13.5	8	33.0	91
Czech Republic, Prague	-16.1	3	28.8	84	Russia, Irkutsk	-33.7	-29	27.0	81
Denmark, Copenhagen	-11.1	12	25.0	77	Russia, Moscow	-23.1	-10	27.6	82
Ecuador, Quito	7.0	45	22.0	72	Russia, Murmansk	-28.7	-20	23.6	74
Egypt, Cairo	7.0	45	38.0	100	Russia, St. Petersburg	-22.6	-9	26.3	79
Estonia, Tallinn	-19.8	-4	24.9	77	Saudi Arabia, Jiddah	14.8	59	40.2	104
Finland, Helsinki	-23.7	-11	25.9	79	Senegal, Dakar	16.2	61	31.8	89
France, Paris	-7.8	18	29.8	86	Singapore, Singapore	22.8	73	33.0	91
Germany, Berlin	-11.8	11	29.9	86	Slovakia, Bratislava	-13.0	9	31.8	89
Germany, Leipzig	-13.4	8	29.7	85	Slovenia, Ljubljana	-13.0	9	30.1	86
Georgia, Tbilisi	-6.0	21	33.5	92	South Africa, Pretoria	3.9	39	31.9	89
Greece, Athens	1.2	34	34.1	93	Spain, Barcelona	0.1	32	29.3	85
Greenland, Dundas	-37.1	-35	12.2	54	Spain, Sevilla	1.2	34	39.8	104
Guam, Anderson AFB	23.3	74	31.2	88	Sweden, Stockholm	-18.9	-2	26.8	80
Hungary, Budapest	-13.2	8	32.1	90	Switzerland, Geneva	-8.0	18	30.1	86
Iceland, Reykjavik	-9.8	14	15.6	60	Syria, Damascus	-4.1	25	38.1	101
India, Bombay	16.5	62	35.0	95	Tawain, Taipei	8.8	48	34.6	94
India, New Delhi	6.6	44	41.7	107	Tajikistan, Dushanbe	-7.3	19	37.1	99
Ireland, Dublin	-1.6	29	22.0	72	Thailand, Bangkok	18.4	65	37.1	99
Israel, Jerusalem	0.6	33	31.6	89	Tunisia, Tunis	4.9	41	36.7	98
Italy, Rome	-0.9	30	30.8	87	Turkey, Istanbul	-3.2	26	30.2	86
Jamaica, Kingston	21.9	71	33.2	92	Turkmenistan, Ashgabat	-6.9	20	40.1	104
Japan, Osaka	-2.0	28	34.0	93	United Kingdom, London	-5.6	22	26.4	80
Japan, Sapporo	-11.0	12	29.1	84	Ukraine, Kyiv	-19.0	-2	28.2	83
Japan, Tokyo	-0.8	31	32.8	91	United Arab Emirates, Abu Dhabi	10.9	52	43.8	111
Jordan, Amman	0.8	33	34.9	95	Uruguay, Montevideo	1.8	35	31.9	89
Kazakhstan, Oral	-27.6	-18	33.8	93	Uzbekistan, Tashkent	-10.3	13	38.0	100
Kenya, Nairobi	9.5	49	29.0	84	Venezuela, Caracas	20.9	70	33.2	92
Korea, North, Wonsan	-11.0	12	31.0	88	Vietnam, Ho Chi Minh City	20.0	68	35.1	95
Korea, South, Seoul	-14.1	7	31.8	89	Yugoslavia, Belgrade	-11.5	11	33.4	92
Kuwait, Kuwait	3.2	38	47.2	117	Zimbabwe, Harare	7.0	45	30.1	86
Latvia, Riga	-19.6	-3	26.1	79					

Table 2 data has been extracted from the 2002 ASHRAE Fundamentals Handbook, Chapter 14 Appendix. Section 7.2 illustrates use of the data.

for I in lieu of the range of values, if appropriate. These listed values can be used to assist in calculating moisture growth effects for use in joint width calculations. Section 7.5 illustrates use of the data.

5.6.2 For sealant joints, the dominant effect on a reversible change in joint width is usually due to temperature change of a material or system. The inclusion of reversible moisture-induced growth with thermal movement may not be a truly additive effect. Moisture content tends to decrease with a rise in wall surface temperature and increase with a drop in wall surface temperature, thereby producing thermal movement and moisture-induced growth that are somewhat compensating but that may not necessarily occur simultaneously. The net sealant

joint movement due to thermal and moisture effects may be difficult or impossible to determine, so some judgment must be used by the design professional when reversible moisture growth is considered (See 7.5.1).

5.7 *Live Load Movement*—Deflection caused by structure or floor live loading should be considered for a horizontal sealant joint opening, as is done for example, in designing a joint for multi-story construction (3). A structural engineer can supply live load deflection criteria for sealant joint design.

5.7.1 Actual live loads can be highly variable (9). A multi-story building, with the same design live load for all floors, will have the actual live load (which can be substantially

**TABLE 3 Average Coefficients of Linear Thermal Movement ( $\alpha$ ) for Some Building Materials**  
(multiply by  $10^{-6}$ )

NOTE 1—The coefficient of movement for natural materials (brick, stone, wood, etc.) or fabrications of natural materials can be highly variable. If a specific material is contemplated then the coefficient for that material should be established and used rather than an average value.

Materials	Celsius (mm/mm/°C)	Fahrenheit (in/in/°F)	Materials	Celsius (mm/mm/°C)	Fahrenheit (in/in/°F)
Aluminum:			Plastic:		
5005 alloy	23.8	13.2	Acrylic sheet	74.0	41.0
3003 alloy	23.2	12.9	High impact acrylic	82.0	50.0
6061 alloy	23.8	13.2	Polycarbonate	68.4	38.0
Brass:			Steel, carbon	12.1	6.7
230 alloy	18.7	10.4	Steel, stainless:		
Bronze:			301 alloy	16.9	9.4
220 alloy	18.4	10.2	302 alloy	17.3	9.6
385 alloy	20.9	11.6	304 alloy	17.3	9.6
655 alloy	18.0	10.0	316 alloy	16.0	8.9
Clay masonry:			410 alloy	11.0	6.1
Clay or shale brick	6.5	3.6	430 alloy	10.4	5.8
Fire clay brick or tile	4.5	2.5	Stone:		
Clay or shale tile	5.9	3.3	Granite	5.0-11.0	2.8-6.1
Concrete masonry:			Limestone	4.0-12.0	2.2-6.7
Dense Aggregate	9.4	5.2	Marble	6.7-22.1	3.7-12.3
Lightweight aggregate	7.7	4.3	Sandstone	8.0-12.0	4.4-6.7
Concrete:			Slate	8.0-10.0	4.4-5.6
Calcareous aggregate	9.0	5.0	Travertine	6.0-10.0	3.3-5.6
Silicious aggregate	10.8	6.0	Tin	21.1	11.7
Quartzite aggregate	12.6	7.0	Wood:		
Copper			Parallel to fiber		
110 alloy, soft	16.9	9.4	Fir	3.8	2.1
110 alloy, cold rolled	17.6	9.8	Maple	6.5	3.6
122 alloy	16.9	9.4	Oak	4.9	2.7
Glass	9.0	5.0	Pine	5.4	3.0
Iron			Perpendicular to fiber		
Cast, grey	10.6	5.9	Fir	57.6	32.0
Wrought	12.6	6.7	Maple	48.6	27.0
Lead	28.6	15.9	Oak	54.0	30.0
Magnesium	28.8	16.0	Pine	34.2	19.0
Monel	14.0	7.8	Zinc:		
Plaster, gypsum:			Rolled	31.3	17.4
Sand aggregate	11.7-12.2	6.5-6.75	Alloy, with grain	23.4	13.0
Perlite aggregate	13.1-13.2	7.3-7.35	Alloy, across grain	17.6	9.8
Vermiculite aggregate	15.1-15.5	8.4-8.6			

ASTM C1472-10

**TABLE 4 Coefficients of Linear Moisture Growth for Some Building Materials**

NOTE 1—(–) indicates a reduction, (+) indicates an increase, and NA not available.

Materials	Growth, Percent	
	Reversible (R)	Irreversible (I)
Concrete:		
Gravel aggregate	0.02-0.06	0.03-0.08 (–)
Limestone aggregate	0.02-0.03	0.03-0.04 (–)
Lightweight aggregate	0.03-0.06	0.03-0.09 (–)
Concrete masonry:		
Dense aggregate	0.02-0.04	0.02-0.06 (–)
Lightweight aggregate	0.03-0.06	0.02-0.06 (–)
Clay masonry:		
Clay or shale brick	0.02	0.02-0.09 (+)
Stone:		
Limestone	0.01	NA
Sandstone	0.07	NA

less than a code prescribed value) vary from floor to floor and from one area of a floor to another. Very rarely will the live load be uniform everywhere. Where live load (and thus deflection) of a structure varies, the relative difference in live load deflection between floors should be considered in joint width design.

5.7.2 Most often live load deflection occurs after the joint has been sealed and, therefore, could be considered an irreversible narrowing of the sealant joint opening, provided the loading conditions remain relatively static. If live loading will be highly variable, such as in a warehouse, then live load deflection could be treated as a reversible movement. The design professional should evaluate these situations and determine how live load deflection is best accommodated.

5.8 *Dead Load Movement*—Deflection caused by structure or floor dead loading should also be considered for a horizontal sealant joint opening (3). A structural engineer can supply dead load deflection criteria for sealant joint design. Dead load deflection of a structure usually occurs before a joint is sealed. There may be a portion that could occur after a joint has been sealed; for instance, when fixed equipment may be installed. Dead load deflection is an irreversible narrowing of a sealant joint opening width for most applications. In multi-story construction, dead load deflection that narrows a sealant joint opening at one floor may have a tendency to widen the sealant joint opening at the floor above.

5.9 *Wind Load Movement*—Depending on building type, framing system, and anticipated wind load, lateral sway or drift of a building and its effect on a sealant joint in a wall may have

to be considered (10). The per-story lateral sway or drift can be determined by a structural engineer. Lateral sway or drift can occur both normal to and in the plane of the wall and both effects on a sealant joint should be considered.

**5.10 Seismic Movement**—In general, sealant joints can be designed for seismic movement. However, the width of the joint to accommodate the expected movement may become large and visually objectionable. Installation of sealant in a large opening can be impractical or may require special techniques. In general, it is usually more appropriate to use readily available preformed gasket systems rather than a liquid-applied sealant for these applications.

**5.11 Movement During Sealant Curing**—The movement capability of sealant is established by laboratory testing of small specimens using Test Method C719, after a sealant has been allowed to cure and attain its intended properties. Experience garnered from sealant joint failures has indicated that some joints will experience movement after installation, sometimes sizable, during the period when the sealant is curing (11). The character of the materials or systems in which the joint occurs is a significant factor in determining the degree and rate of movement that will occur. Building monitoring has shown that materials or systems with high thermal mass experience low rates of movement while those of low mass, that are well insulated, experience high rates of movement (6). With solar warming, the rate of change of a material or system surface temperature closely correlates with the rate of movement of a sealant joint. Other studies have described the character of sealant joint failures due to movement during cure and have shown that movement during cure can alter the cured performance characteristics of a sealant (12-15). Performance parameters that can be altered include tensile strength, compressive strength, modulus, adhesion to substrates, and sealant tear resistance. Physical aspects that can be altered include introduction of exposed and hidden surface cracking and production of voids within the body of the sealant. These types of changes or damage could be detrimental for the sealant joint if of a sufficient magnitude. The type and degree of these changes for a particular sealant will vary depending on the generic polymer backbone and particular sealant formulation. As a result of these effects that can occur during sealant cure, the ultimate movement capability of a sealant can be adversely affected. The calculations in this guide are based on cured sealant properties. If a particular installation can not avoid a movement during cure situation from occurring, then compensation for lessened ultimate sealant properties should occur. Compensation can include installing the sealant and allowing it to cure at times of least expected movement or testing a particular sealant to the movement during cure characteristics expected to occur and then designing the joint appropriately. Guide C1193 should be consulted for an in-depth discussion of movement-during-cure.

**5.12 Elastic Frame Shortening**—Multi-story concrete structures, and to a lesser degree steel, shorten elastically almost immediately due to the application of loads (9, 10, 16). Frame shortening, the degree of which can be estimated by a structural engineer, will cause an irreversible narrowing of a horizontal sealant joint opening in multi-story construction.

Frame shortening can be compensated for by building each floor level higher, in effect negating most of the shortening, or the narrowing of joint width can become another performance factor considered in the design of a sealant joint. Some of the frame shortening effect will occur before the wall cladding is erected and the size of the joint opening is established. Presently, it is common practice to determine the amount of shortening that occurs before the joint opening is established using an informed and conservative estimate.

**5.13 Creep**—The time-dependent deformation of materials while loaded, in particular for a concrete structure, should be included in sealant joint design. This deformation, which occurs at a decreasing rate as time progresses, can cause a continuing decrease in the width of horizontal joint openings in multi-story and other buildings. Creep, in contrast to elastic frame shortening, can occur over a long period of time (9, 10, 16). A structural engineer can provide creep deflection criteria for sealant joint design.

**5.14 Shrinkage**—Concrete framed structures will undergo long-term shrinkage for a period of months (9, 10, 16). Other cement based systems, such as load-bearing concrete masonry unit construction, can also experience the same effect. Shrinkage is mainly due to loss of moisture during the initial curing of concrete. The rate of shrinkage is dependent on the amount of water present, ambient temperatures, rate of air movement, relative humidity of the surrounding air, the shape and size of the concrete section, and the amount and type of aggregate in the concrete mix, among others. Table 4 and Ref (8) list guidelines for some shrinkage values for concrete and other materials. Shrinkage criteria can be provided by a structural engineer and included in sealant joint design or the shrinkage effect can be somewhat compensated for by building each floor level slightly higher. In any event, shrinkage effects should be included in the design of a horizontal joint in multi-story construction. Some of the frame shrinkage effect will occur before a wall cladding is erected and the size of the joint opening is established. Presently, the amount of shrinkage that occurs before a joint opening is established is determined by an informed estimate and, therefore, should be conservative.

**5.15 Construction Tolerances**—A typical building is a combination of site-built and factory fabricated materials, components, and sub-systems. These materials and systems can be combined and constructed in complex arrangements. ASTM and industry trade associations, among others, establish industry recognized standards for construction tolerances (17). Industry established tolerances should be carefully evaluated since, in some cases, they can be quite liberal and not appropriate for sealant joint design. For some materials or systems there are no industry recognized tolerances or the available tolerances are not directly applicable to sealant joint design. In these instances, a design professional should evaluate the conditions and establish tolerances for sealant joint work. A word of caution: ignoring the effects of construction tolerances, when designing sealant joints, will very often result in a failure of the joint, and frequently a failure of adjacent materials or systems that, due to the joint narrowing, may come into detrimental contact with each other. Conversely, changing construction tolerances, by exceeding industry

recommendations, needs to be carefully considered, since conditions can be created that can not be effectively achieved. Construction tolerances should be indicated for the sealant joint design since they establish a level of quality and may affect the cost and performance of the work. Experience has indicated that, in general, if tolerances are not adequately considered, sealant joints become too narrow, not too large. It is beyond the scope of this guide to describe the effects of tolerances in detail. Reference 17 should be consulted as well as industry specific standards.

5.15.1 *Material*—Construction materials have a permissible variation for their dimensions. For example, a face brick is nominally 57 mm (2-1/4 in.) high by 203 mm (8 in.) long by 89 mm (3-1/2 in.) thick. Depending on the type of brick, the permissible manufacturing tolerance or variation could be as much as 2 to 6 mm (3/32 to 1/4 in.) for the 203 mm (8 in.) dimension, as indicated by Specification C216. Material dimensional variation may have to be included as a performance factor in the design of a sealant joint. If material tolerance is not considered, an improper sealant joint width could result.

5.15.2 *Fabrication*—Fabricated materials or assemblies of materials also have dimensional variance. Factory fabrication will usually permit a smaller variation in dimension than job site fabrication. For example, factory fabricated unitized metal and glass curtain wall frames may permit  $\pm 2$  mm (1/16 in.) tolerance or less for the length and width of the frames, while job site assembly of a face brick wall, depending on brick type, may permit no better than  $\pm 6$  mm (1/4 in.) variance for the constructed width of an expansion joint opening in a wall. Also, a precast concrete wall panel that is 9.1 m (30 ft) long, according to MNL-177-77, can have a tolerance for that dimension at the time of casting of +3, -6 mm (+1/8, -1/4 in.). Realistic fabrication tolerances should be established and enforced so that the designed joint opening width is attained and sealant performance is not compromised, especially by a joint opening that is constructed too narrow in width.

5.15.3 *Erection*—Frequently, wall materials or systems cannot be placed on a building exactly where called for by the contract documents. Some location variance for building components should be provided so that a deficient joint opening width does not occur. For example, a unitized metal and glass curtain wall frame may be erected no closer then  $\pm 3$  mm (1/8

in.) to height or lateral locations shown by the contract documents. The precast concrete wall panel described in 5.15.2, according to MNL-177-77, may not be able to be placed any closer to its theoretical location than  $\pm 6$  mm ( $\pm 1/4$  in.). Locational variance of materials or systems will affect the constructed width of a sealant joint opening that occurs between wall elements. Erection tolerances must be intelligently developed so that they are realistic and also attainable at the building site.

5.15.4 *Accumulated Tolerances*—When several materials, components, or subsystems are combined on the face of a building their respective tolerances may not be additive. For example, not all materials, components, or subsystems will be oversize or undersize. Statistically, it is likely that there will be a mix of under and oversize and unlikely that all would be over or under size. It is possible to statistically account for several combined tolerances to arrive at a probable total tolerance. There is not an industry consensus on a standardized method to account for combined tolerances; however, Reference (17) can be consulted for guidance.

6. Sealant Joint Movement

6.1 *General*—There are four basic movements that sealant joints experience (See Fig. 1). These movements are: compression (C), extension (E), longitudinal extension (EL), and transverse extension (ET). Longitudinal and transverse extension is a shearing effect on a sealant joint (See Fig. 2). Thermal movement is usually the largest contributor; however, other performance factors can contribute to producing these movements. The following describes these movements.

6.2 *Compression*—A sealant joint that primarily experiences compression (C), a narrowing of the opening width, is typically one where the sealant is installed during the cool or cold months of the year. Therefore, when the warm summer months occur the thermal growth of adjacent materials causes a narrowing of the sealant joint opening, thereby compressing the sealant.

6.3 *Extension*—A sealant joint that primarily experiences extension (E), an increase in the opening width, is typically one where the sealant is installed during the warm months of the year. Therefore, when the cool or cold months occur the

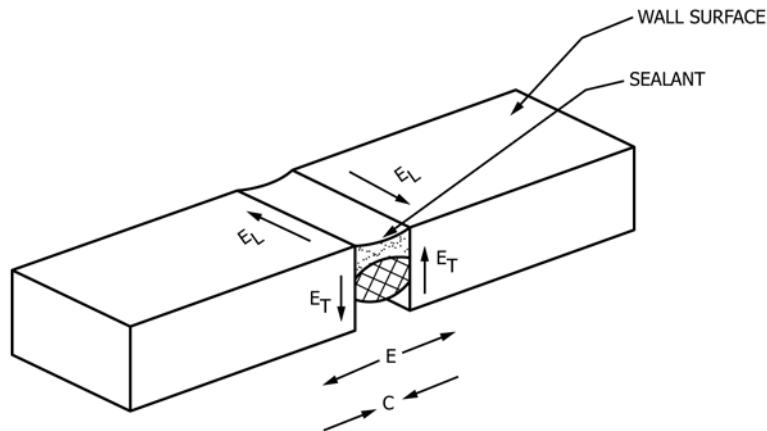

FIG. 1 Typical Sealant Joint Movements



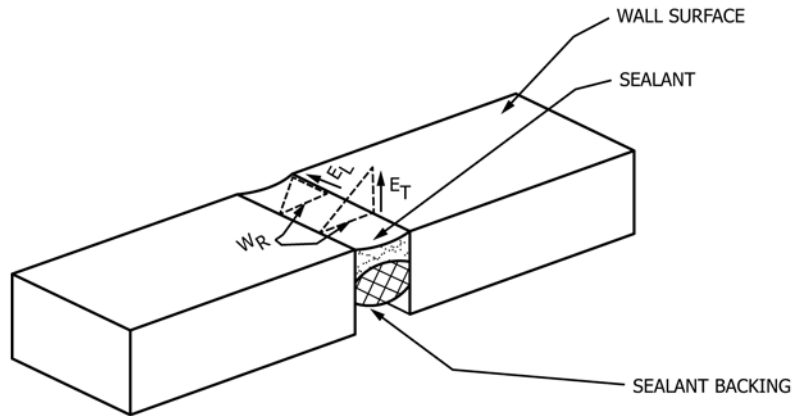

FIG. 2 Longitudinal or Transverse Extension Movement

thermal contraction of adjacent materials causes a widening of the joint opening, thereby extending the sealant.

6.4 *Extension and Compression*—A sealant joint installed during the fall or spring months, or when temperatures are moderate, can experience both compression ( $C$ ) as well as extension ( $E$ ) since the sealant is not installed at or near the hottest or coldest design temperatures. This results in compression during the summer months and extension during the winter months, however typically neither movement is as large as would occur as described in 6.2 or 6.3.

6.5 *Longitudinal Extension*—A sealant joint that experiences longitudinal extension ( $E_L$ ), a lengthwise displacement of one side of the joint relative to the other, is typically one that has different materials or systems forming the sides of the joint or the same material on both sides of the joint but with different support conditions for both sides (See Fig. 2). Examples of this effect include a brick masonry wall on one side and an aluminum curtain wall mullion for the other, or a face brick veneer on both sides but supported periodically by shelf angles on one side and at grade on the other. These different materials or support conditions will result in different responses to the same temperature change, resulting in a diagonal lengthening of the sealant due to the differential movement between the materials. The movement is in a direction parallel to the joint opening. This movement is dependent on the location of each materials' supports, the unrestrained length of the respective

materials, and the expected temperature change for each material. This movement usually reaches its maximum only along part of the length of a sealant joint. Irreversible moisture growth of fired clay products such as face brick can also contribute to the effect.

6.6 *Transverse Extension*—A sealant joint that experiences transverse extension ( $E_T$ ), an out-of-plane movement crosswise to the joint face, of one side of the joint opening relative to the other, is typically one that occurs at the juncture of walls that change plane, such as at a corner. As the materials forming the sides of the joint experience thermal movement, a diagonal lengthening of the sealant can occur crosswise to the plane of the sealant joint face. (See Fig. 2.)

6.7 *Movement Combinations*—Frequently, sealant joints must accommodate more than one of the above-described movements. Examples include the previously described extension and compression, as well as extension and/or compression combined with longitudinal or transverse extension. Fig. 3 is representative of extension and compression combined with transverse extension movement crosswise to the plane of the joint (See 6.6). Fig. 4 is representative of extension and compression combined with longitudinal extension movement in the plane of the joint (See 6.5). The effects of these movements can be combined to establish the joint width required to satisfy those expected combined movements. The

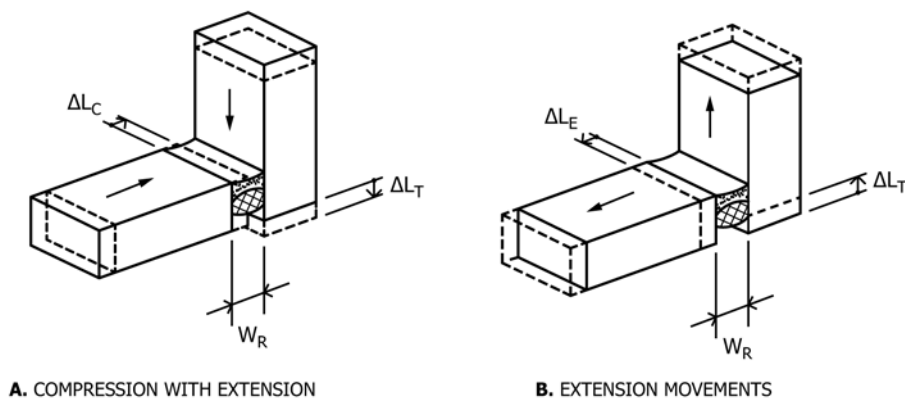

FIG. 3 Extension and Compression Movement with Transverse Extension

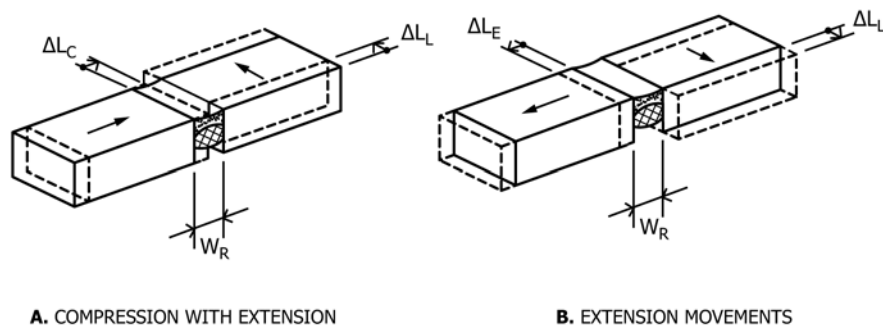

FIG. 4 Extension and Compression Movement with Longitudinal Extension

design professional should evaluate the types of movement the joint will experience and design accordingly.

6.8 *Sealant Stresses in Extension and Shear*—Testing has been performed on various polyurethane and silicone sealants to establish how shear stresses produced in those sealants, when in longitudinal or transverse extension, compare with the tensile stresses produced when the sealants are in extension (18). The results of that work indicate that the use of a trigonometric equation, based on the triangular relationship indicated by Fig. 2, in conjunction with a sealant’s tensile modulus properties, can successfully predict allowable shear movement for a sealant joint, since the shear stress did not exceed the tensile stress for a given elongation (See 7.6.3).

6.9 *Sealant Movement Capability and Rating*

6.9.1 *Liquid-Applied Sealant*—Sealant manufacturers rate the movement capability of their liquid-applied sealants, generally, as a plus-minus value. Liquid-applied sealants meeting Specification C920 are rated as  $\pm 12\frac{1}{2} \pm 25$ ,  $\pm 35$ ,  $\pm 50$  and  $+100/-50$  percent. These values are determined primarily by Test Method C719. To achieve the rated movement capacity, it is important to verify that a particular sealant will adhere to a particular substrate and that the movement rating is applicable to a particular set of circumstances. For example, a particular sealant may adhere to an unprimed brick masonry substrate but not to an unprimed concrete substrate. It is prudent for the joint designer to have the sealant manufacturer test, using Test Method C794, a particular sealant with actual samples of a particular substrate prior to sealant installation. Sealant manufacturers, in general, state that a sealant will adhere to a generic substrate; however, it is always prudent to have a particular sealant and substrate combination tested for adequate adhesion both with and without a primer. Without adequate

long-term adhesion a sealant’s movement capability is irrelevant. The joint designer, after establishing that there is adequate adhesion, is faced with a fundamental decision. Should the sealant be used at its manufacturer’s rating? If performance factors and tolerances cannot be adequately identified then using the sealant at less than its manufacturer’s rating would be prudent. The quality of expected workmanship can also be a factor to be considered when establishing the sealant movement rating that will be used for calculation. Additionally, it should be realized that test Method C719 is only a 10-cycle test procedure that may not adequately describe characteristics that affect sealant movement capability and may not adequately predict long-term performance and durability. Also, if remedial sealant work is to be performed using already contaminated substrates, as would occur when resealing a previous sealant failure, then using the sealant at a lesser value than its rating may also be prudent. In this case, using it at less than its rating would cause less stress to develop at the sealant’s adhesion to the substrate, where it may not be possible to attain optimum adhesion. Using a sealant at a lesser value than its rating does not mean that laboratory and field adhesion tests are not required. They should always be performed. The amount of reduction in movement capacity from the manufacturers rating is mostly a judgment call, based on experience and a joint design’s particular circumstances.

6.9.2 *Precured Sealant Extrusion*—These products are formulated and extruded by the manufacturer to provide a precured, low-modulus shape that is then adhered in-place (See Fig. 5). Specification C1518 describes precured sealant extrusion properties. Sealant manufacturers rate the movement capability of precured sealant extrusions, generally, as a plus-minus value. Presently, a movement capability of  $+200/$

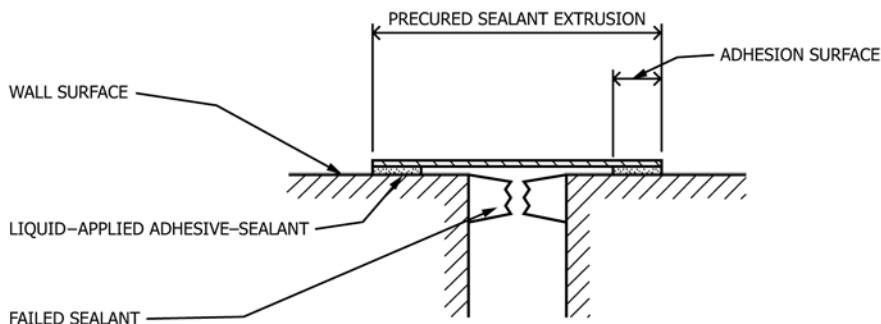

FIG. 5 Cross-Section of a Typical Precured Sealant Extrusion Application