

---

---

**Glass packaging — 26 H 180 crown  
finish — Dimensions**

*Emballage en verre — Bague couronne 26 H 180 — Dimensions*

**iTeh STANDARD PREVIEW**  
**(standards.iteh.ai)**

[ISO 12821:2019](https://standards.iteh.ai/catalog/standards/sist/2d5ef6fe-f743-408b-8041-01e9c8c34e8/iso-12821-2019)

<https://standards.iteh.ai/catalog/standards/sist/2d5ef6fe-f743-408b-8041-01e9c8c34e8/iso-12821-2019>



**iTeh STANDARD PREVIEW**  
**(standards.iteh.ai)**

ISO 12821:2019

<https://standards.iteh.ai/catalog/standards/sist/2d5ef6fe-f743-408b-8041-01e9c8c34e8/iso-12821-2019>



**COPYRIGHT PROTECTED DOCUMENT**

© ISO 2019

All rights reserved. Unless otherwise specified, or required in the context of its implementation, no part of this publication may be reproduced or utilized otherwise in any form or by any means, electronic or mechanical, including photocopying, or posting on the internet or an intranet, without prior written permission. Permission can be requested from either ISO at the address below or ISO's member body in the country of the requester.

ISO copyright office  
CP 401 • Ch. de Blandonnet 8  
CH-1214 Vernier, Geneva  
Phone: +41 22 749 01 11  
Fax: +41 22 749 09 47  
Email: [copyright@iso.org](mailto:copyright@iso.org)  
Website: [www.iso.org](http://www.iso.org)

Published in Switzerland

# Contents

	Page
Foreword.....	iv
Introduction.....	v
1 Scope.....	1
2 Normative references.....	1
3 Terms and definitions.....	1
4 Dimensions.....	1
Bibliography.....	6

## iTeh STANDARD PREVIEW (standards.iteh.ai)

[ISO 12821:2019](https://standards.iteh.ai/catalog/standards/sist/2d5ef6fe-f743-408b-8041-01e9c8c34e8/iso-12821-2019)

<https://standards.iteh.ai/catalog/standards/sist/2d5ef6fe-f743-408b-8041-01e9c8c34e8/iso-12821-2019>

## Foreword

ISO (the International Organization for Standardization) is a worldwide federation of national standards bodies (ISO member bodies). The work of preparing International Standards is normally carried out through ISO technical committees. Each member body interested in a subject for which a technical committee has been established has the right to be represented on that committee. International organizations, governmental and non-governmental, in liaison with ISO, also take part in the work. ISO collaborates closely with the International Electrotechnical Commission (IEC) on all matters of electrotechnical standardization.

The procedures used to develop this document and those intended for its further maintenance are described in the ISO/IEC Directives, Part 1. In particular, the different approval criteria needed for the different types of ISO documents should be noted. This document was drafted in accordance with the editorial rules of the ISO/IEC Directives, Part 2 (see [www.iso.org/directives](http://www.iso.org/directives)).

Attention is drawn to the possibility that some of the elements of this document may be the subject of patent rights. ISO shall not be held responsible for identifying any or all such patent rights. Details of any patent rights identified during the development of the document will be in the Introduction and/or on the ISO list of patent declarations received (see [www.iso.org/patents](http://www.iso.org/patents)).

Any trade name used in this document is information given for the convenience of users and does not constitute an endorsement.

For an explanation of the voluntary nature of standards, the meaning of ISO specific terms and expressions related to conformity assessment, as well as information about ISO's adherence to the World Trade Organization (WTO) principles in the Technical Barriers to Trade (TBT), see [www.iso.org/iso/foreword.html](http://www.iso.org/iso/foreword.html).

This document was prepared by the European Committee for Standardization (CEN) Technical Committee CEN/TC 261, *Packaging*, in collaboration with ISO Technical Committee TC 63, *Glass containers*, in accordance with the agreement on technical cooperation between ISO and CEN (Vienna Agreement).

This second edition cancels and replaces the first edition (ISO 12821:2013), which has been technically revised.

The main changes compared to the previous edition are as follows:

- deletion of the sentence below [Figure 1](#): "A controlled bore of 16,6 mm to 15,6 mm between 1,5 mm and 3,0 mm from the top is recommended for bottles which are to be resealed and sterilized";
- modification of footnotes to [Figures 1, 4](#) and [5](#) and correction of [Figure 5](#) for the reference line of the bore diameter indication;
- further details on the crimping edge ("P" point);
- deletion of reference to some Cete documents;
- editorial corrections.

Any feedback or questions on this document should be directed to the user's national standards body. A complete listing of these bodies can be found at [www.iso.org/members.html](http://www.iso.org/members.html).

## Introduction

This document is based on Cetie (International Technical Center for Bottling and related Packaging) data sheet GME 13.01 (2007).

Efficient packaging is of great importance for the distribution and the protection of goods. Insufficient or inappropriate packaging can lead to damage or wastage of the contents of the pack.

## iTeh STANDARD PREVIEW (standards.iteh.ai)

[ISO 12821:2019](https://standards.iteh.ai/catalog/standards/sist/2d5ef6fe-f743-408b-8041-01e9c8c34e8/iso-12821-2019)

<https://standards.iteh.ai/catalog/standards/sist/2d5ef6fe-f743-408b-8041-01e9c8c34e8/iso-12821-2019>

**iTeh STANDARD PREVIEW**  
**(standards.iteh.ai)**

ISO 12821:2019

<https://standards.iteh.ai/catalog/standards/sist/2d5ef6fe-f743-408b-8041-01e9c8c34e8/iso-12821-2019>

# Glass packaging — 26 H 180 crown finish — Dimensions

## 1 Scope

This document specifies the dimensions of the 26 mm tall crown finish for glass bottles containing beverages. The tall crown finish is designed to use a metal crown cap (see e.g. EN 17177).

## 2 Normative references

The following documents are referred to in the text in such a way that some or all of their content constitutes requirements of this document. For dated references, only the edition cited applies. For undated references, the latest edition of the referenced document (including any amendments) applies.

ISO 9058, *Glass containers — Standard tolerances for bottles*

## 3 Terms and definitions

No terms and definitions are listed in this document.

ISO and IEC maintain terminological databases for use in standardization at the following addresses:

- ISO Online browsing platform: available at <https://www.iso.org/obp>
- IEC Electropedia: available at <http://www.electropedia.org/>

## 4 Dimensions

The design and dimensions of the finish shall be as shown in [Figures 1, 2, 3, 4, and 5](#).

Details which are not specified shall be selected in accordance with the application.

The general tolerances shall be in accordance with ISO 9058.

Dimensions in millimetres

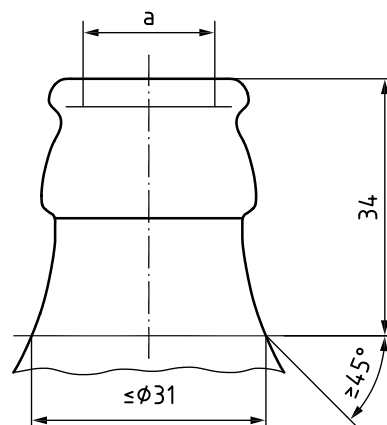

- a  $\phi$  between 18,0 mm max. and 16,5 mm min. measured at 3 mm max. down from the top, see key d in [Figures 4 and 5](#). Minimum through  $\phi$  bore 15,5 mm.

**Figure 1 — Shoulder and bore dimensions**

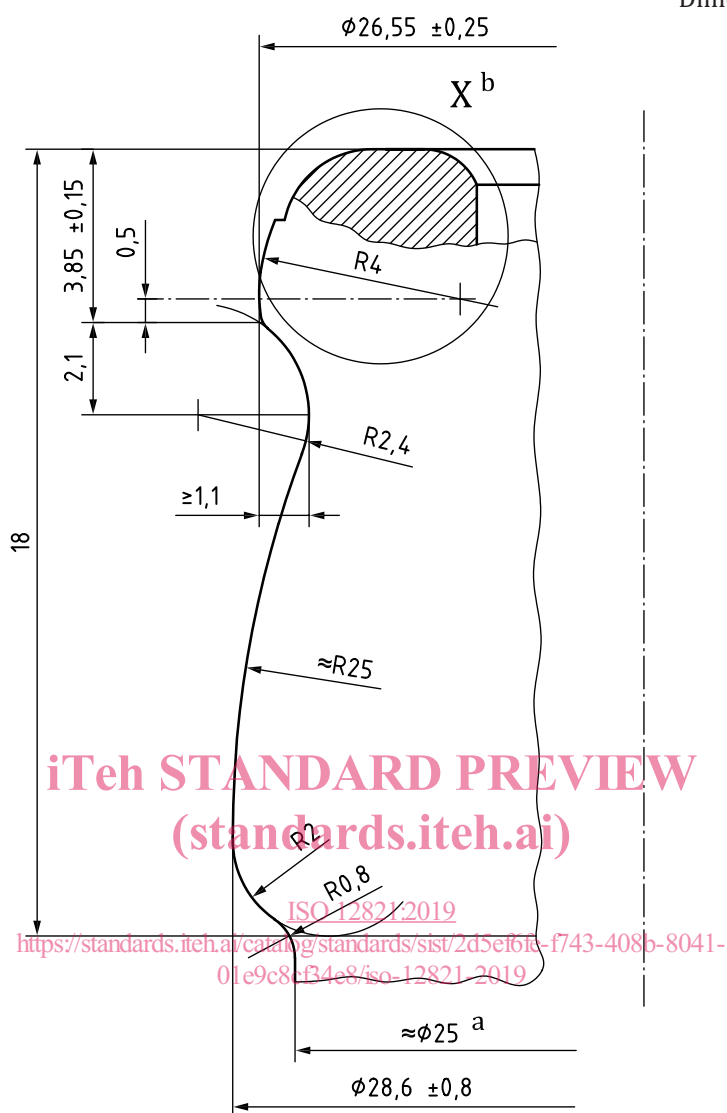

a Nominal diameter to suit glass manufacturer.

b Detail X: see [Figures 4](#) and [5](#).

**Figure 2 — Profile of the finish**



Dimensions in millimetres

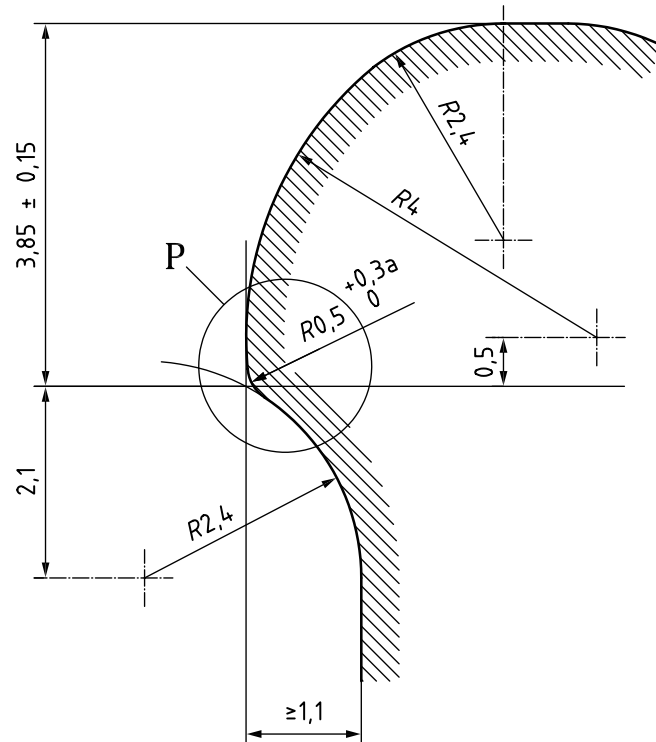

iTeh STANDARD PREVIEW

- <sup>a</sup> For optimum performance, the radius should lie between 0,5 mm and 0,8 mm excluding the vertical mould joint and be as near as possible to 0,5 mm.

ISO 12821:2019

<http://www.iso.org/standard/674986-804p> **Figure 3 — Definition of the crimping edge ("P" point)**

<http://www.iso.org/standard/674986-804p>  
01e9c8c34e8/iso-12821-2019

The detail P figures the dimensions relating to the contact zone between the finish and the corrugated skirt of the cap when crimped, known as the "P point".