



Designation: E1043 – 00(Reapproved 2010)

Standard Specification for Pipets, Milk and Cream Examination¹

This standard is issued under the fixed designation E1043; the number immediately following the designation indicates the year of original adoption or, in the case of revision, the year of last revision. A number in parentheses indicates the year of last reapproval. A superscript epsilon (ϵ) indicates an editorial change since the last revision or reapproval.

1. Scope

1.1 This specification covers miscellaneous pipets suitable for use in milk and cream testing procedures.

1.2 The values stated in SI units are to be regarded as standard. No other units of measurement are included in this standard.

2. Referenced Documents

2.1 *ASTM Standards*:²

E542 Practice for Calibration of Laboratory Volumetric Apparatus

E671 Specification for Maximum Permissible Thermal Residual Stress in Annealed Glass Laboratory Apparatus

E920 Specification for Commercially Packaged Laboratory Apparatus

E921 Specification for Export Packaged Laboratory Apparatus

E1133 Practice for Performance Testing of Packaged Laboratory Apparatus for United States Government Procurements

E1157 Specification for Sampling and Testing of Reusable Laboratory Glassware

3. Classification

3.1 Pipets covered by this specification shall be of the following types:

3.1.1 *Type I*—Breed and brew pipet.

3.1.2 *Type II*—Milk pipet, Babcock.

3.1.2.1 *Type II A*—Milk pipet, Babcock variation.

3.1.2.2 *Type II B*—Milk pipet, Babcock variation.

3.1.3 *Type III*—Cream pipet.

3.1.3.1 *Type III A*—Cream pipet, additional size.

3.1.4 *Type IV*—Milk diluting pipet.

3.1.4.1 *Type IV A*—Milk diluting pipet, additional sizes.

¹ This specification is under the jurisdiction of ASTM Committee E41 on Laboratory Apparatus and is the direct responsibility of Subcommittee E41.01 on Apparatus.

Current edition approved July 1, 2010. Published July 2010. Originally approved in 1985. Last previous edition approved in 2005 as E1043 – 00 (2005). DOI: 10.1520/E1043-00R10.

² For referenced ASTM standards, visit the ASTM website, www.astm.org, or contact ASTM Customer Service at service@astm.org. For *Annual Book of ASTM Standards* volume information, refer to the standard's Document Summary page on the ASTM website.

3.1.5 *Type V*—Milk diluting pipet.

3.1.6 *Type VI*—Milk pipet, Gerber.

4. Material and Annealing

4.1 Pipets shall be made of high quality apparatus glass, suitable in all respects for the purpose intended.

4.2 Maximum residual thermal stress shall conform to Specification E671.

5. Style and Design

5.1 *Type I, Breed and Brew Pipet* (see Note 1)—Style and design of capillary pipets shall be in strict conformance with Fig. 1, Type I. Pipets shall be without bulb, and shall be suitable for use in the direct count method of milk examination in conformance with the test procedures described in the 14th edition of *Standard Methods for the Examination of Dairy Products*³ for pipet and slide method. The pipet shall be calibrated to deliver, when blown out, $0.01 \pm 0.001 \text{ cm}^3$ of milk having a specific gravity of 1.032 at 20°C. Tips shall be blunt, ground, or polished to discharge milk cleanly.

NOTE 1—Type I pipets (5.1), before being used in New York, must be submitted to the Director of the State Ford Laboratory, Albany, NY, for examination.

5.2 *Type II, Milk Pipet*—Milk pipets shall be Babcock pipets suitable for testing the butter fat content of milk. The ends shall be at right angles to the axis. The bulb shall be symmetrical. The tip shall taper slightly over the terminal 5 to 20 cm^3 , but the inside diameter at the end must be able to deliver within 5 to 8 s when filled with water. The end shall be fire-polished. The pipet shall be calibrated to contain $17.6 \pm 0.05 \text{ cm}^3$ of water at 20°C, when tested in accordance with Practice E542. The pipet shall be marked to indicate that it contains 17.6 cm^3 at 20°C. The pipet shall be in strict conformance with Fig. 1, Type II.

5.2.1 *Type II A, Milk Pipet*—Same as Type II (5.2) except marked "Sealed" for use in states requiring this special marking. (Alabama, Georgia, Mississippi, New Mexico, North Dakota, Oregon, Tennessee, Washington, and Wisconsin.)

5.2.2 *Type II B, Milk Pipet*—Similar to Type II, however, the pipet shall be calibrated to deliver $17.6 \pm 0.05 \text{ cm}^3$ of water at

³ American Public Health Assoc., *Standard Methods for the Examination of Dairy Products*, 14th edition.

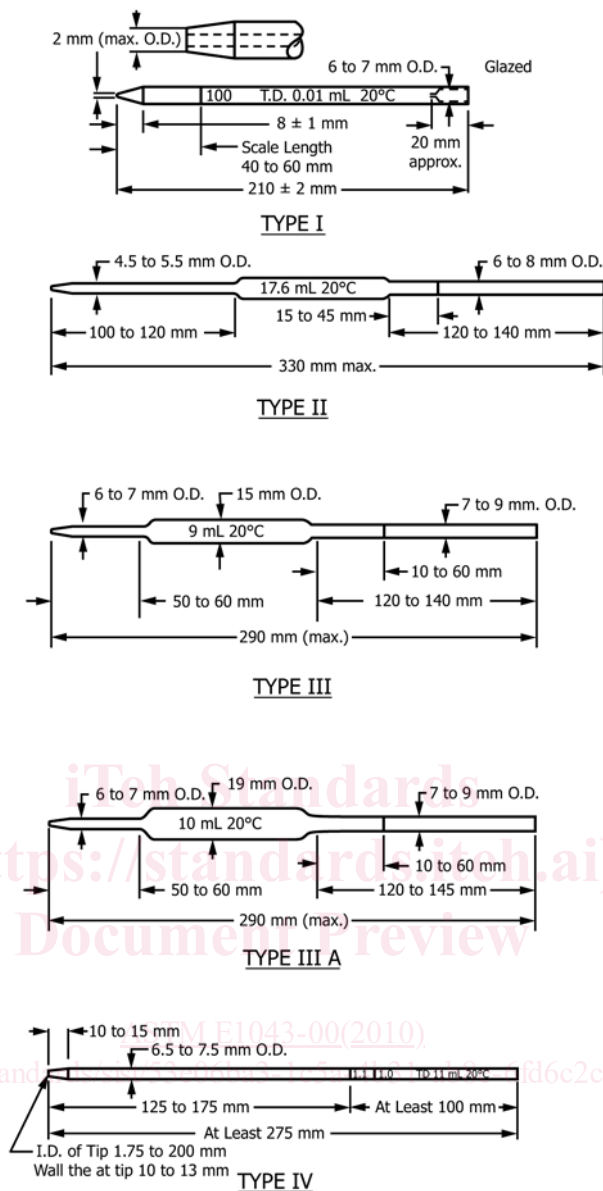

FIG. 1 Pipets, Milk and Cream Examination

20°C, when tested in accordance with Practice E542. The pipet shall be marked to indicate that it delivers 17.6 cm³ at 20°C. The pipet shall be in strict conformance with Fig. 1, Type II. (For use in the state of Nebraska.)

5.3 *Type III, Cream Pipet*—Cream pipets shall be in strict conformance with Fig. 1, Type III. They shall be calibrated to deliver 9 ± 0.10 cm³ at 20°C, using distilled water, with drop remaining in tip blown out 2 s after delivery ceases and added to free delivery volume.

5.3.1 *Type III A, Cream Pipet*—Similar to Type III, however, the pipet shall be calibrated to deliver 18 ± 0.20 cm³ at 20°C when used as described in 5.3. The pipet shall conform with Fig. 1, Type III A.

5.4 *Type IV, Milk Diluting Pipet* (see Note 2)—Milk diluting pipets shall be in strict conformance with Fig. 1, Type IV. They shall have a capacity of 1.1 cm³ and be graduated to deliver at

0.5, 1.0, and 1.1 cm³. They shall be calibrated to contain 0.54, 1.075, and 1.180 cm³ of distilled water at 20°C at the 0.5, 1.0, and 1.1 cm³ graduations, respectively. Tolerance shall be ±0.025 cm³ at any point on the pipet. When used with whole milk, the small amount remaining in the tip, after free delivery has ceased, is blown out and added to the free delivery volume. For diluted milk, the correct volume is delivered without blowing out. The pipet shall not have the frosted band near the top denoting that the pipet is “calibrated” for blow out.

5.4.1 *Type IV A, Milk Diluting Pipets* (see Note 2)—Similar to Type IV, except for size. These pipets are available in 1.0, 2.2, and 11.0 cm³ capacities. These pipets shall be in strict conformance with Fig. 2, Type IV A. Actual volumes of water contained at 20°C at each graduation line are specified as follows: 1.0 (1.075) cm³; 2.0 (2.150) cm³; 2.1 (2.255) cm³; 2.2 (2.360) cm³; and 11 (11.6) cm³. Tolerances at any point