

FINAL
DRAFT

INTERNATIONAL
STANDARD

ISO/FDIS
25619-1

ISO/TC 221

Secretariat: BSI

Voting begins on:
2020-11-25

Voting terminates on:
2021-01-20

Geosynthetics — Determination of compression behaviour —

Part 1: Compressive creep properties

*Géosynthétiques — Détermination du comportement en
compression*

iTeh STANDARD PREVIEW
Partie 1: Propriétés de fluage en compression
(standards.iteh.ai)

[ISO/FDIS 25619-1](https://standards.iteh.ai/catalog/standards/sist/a9367788-16b6-4fbf-a34e-b0f86ceaf52c/iso-fdis-25619-1)

<https://standards.iteh.ai/catalog/standards/sist/a9367788-16b6-4fbf-a34e-b0f86ceaf52c/iso-fdis-25619-1>

RECIPIENTS OF THIS DRAFT ARE INVITED TO SUBMIT, WITH THEIR COMMENTS, NOTIFICATION OF ANY RELEVANT PATENT RIGHTS OF WHICH THEY ARE AWARE AND TO PROVIDE SUPPORTING DOCUMENTATION.

IN ADDITION TO THEIR EVALUATION AS BEING ACCEPTABLE FOR INDUSTRIAL, TECHNOLOGICAL, COMMERCIAL AND USER PURPOSES, DRAFT INTERNATIONAL STANDARDS MAY ON OCCASION HAVE TO BE CONSIDERED IN THE LIGHT OF THEIR POTENTIAL TO BECOME STANDARDS TO WHICH REFERENCE MAY BE MADE IN NATIONAL REGULATIONS.

ISO/CEN PARALLEL PROCESSING



Reference number
ISO/FDIS 25619-1:2020(E)

© ISO 2020

iTeh STANDARD PREVIEW
(standards.iteh.ai)

ISO/FDIS 25619-1

<https://standards.iteh.ai/catalog/standards/sist/a9367788-16b6-4fbf-a34e-b0f86ceaf52c/iso-fdis-25619-1>



COPYRIGHT PROTECTED DOCUMENT

© ISO 2020

All rights reserved. Unless otherwise specified, or required in the context of its implementation, no part of this publication may be reproduced or utilized otherwise in any form or by any means, electronic or mechanical, including photocopying, or posting on the internet or an intranet, without prior written permission. Permission can be requested from either ISO at the address below or ISO's member body in the country of the requester.

ISO copyright office
CP 401 • Ch. de Blandonnet 8
CH-1214 Vernier, Geneva
Phone: +41 22 749 01 11
Email: copyright@iso.org
Website: www.iso.org

Published in Switzerland

Contents

	Page
Foreword	iv
1 Scope	1
2 Normative references	1
3 Terms and definitions	1
4 Test specimens	2
4.1 Sampling	2
4.2 Number and dimensions of test specimens	2
4.3 Conditioning	6
5 Normal compressive load method	6
5.1 Principle	6
5.2 Apparatus	7
5.3 Procedure	8
5.4 Calculations	9
5.5 Test report	10
6 Combined normal and shear load method	11
6.1 Principle	11
6.2 Apparatus	11
6.3 Procedure	12
6.4 Calculations	13
6.5 Test report	14
Annex A (informative) Variations to the index test procedure for site-specific tests	16
Annex B (informative) Typical curves	17

[ISO/FDIS 25619-1](https://standards.iteh.ai/catalog/standards/sist/a9367788-16b6-4fbf-a34e-b0f86ceaf52c/iso-fdis-25619-1)

<https://standards.iteh.ai/catalog/standards/sist/a9367788-16b6-4fbf-a34e-b0f86ceaf52c/iso-fdis-25619-1>

Foreword

ISO (the International Organization for Standardization) is a worldwide federation of national standards bodies (ISO member bodies). The work of preparing International Standards is normally carried out through ISO technical committees. Each member body interested in a subject for which a technical committee has been established has the right to be represented on that committee. International organizations, governmental and non-governmental, in liaison with ISO, also take part in the work. ISO collaborates closely with the International Electrotechnical Commission (IEC) on all matters of electrotechnical standardization.

The procedures used to develop this document and those intended for its further maintenance are described in the ISO/IEC Directives, Part 1. In particular, the different approval criteria needed for the different types of ISO documents should be noted. This document was drafted in accordance with the editorial rules of the ISO/IEC Directives, Part 2 (see www.iso.org/directives).

Attention is drawn to the possibility that some of the elements of this document may be the subject of patent rights. ISO shall not be held responsible for identifying any or all such patent rights. Details of any patent rights identified during the development of the document will be in the Introduction and/or on the ISO list of patent declarations received (see www.iso.org/patents).

Any trade name used in this document is information given for the convenience of users and does not constitute an endorsement.

For an explanation of the voluntary nature of standards, the meaning of ISO specific terms and expressions related to conformity assessment, as well as information about ISO's adherence to the World Trade Organization (WTO) principles in the Technical Barriers to Trade (TBT), see www.iso.org/iso/foreword.html.

This document was prepared by Technical Committee ISO/TC 221, *Geosynthetics*, in collaboration with the European Committee for Standardization (CEN) Technical Committee CEN/TC 189, *Geosynthetics*, in accordance with the Agreement on technical cooperation between ISO and CEN (Vienna Agreement).

This second edition cancels and replaces the first edition (ISO 25619-1:2008) which has been technically revised.

The main changes compared to the previous edition are as follows:

- normative references have been updated;
- dimension and shape of the specimen for different types of geosynthetics have been introduced;
- calculation of the correct area for structure in which loading is resisted at defined points or at defined lines have been introduced;
- the drawing of a test apparatus for compressive shear test that was not described in the test has been deleted.

A list of all parts in the ISO 25619 series can be found on the ISO website.

Any feedback or questions on this document should be directed to the user's national standards body. A complete listing of these bodies can be found at www.iso.org/members.html.

Geosynthetics — Determination of compression behaviour —

Part 1: Compressive creep properties

1 Scope

This document specifies index test methods for determining the compressive creep properties of geosynthetic products. The test specimens are subjected either to normal compressive loading or to a combination of normal compressive loading and shear loading.

The test method with a normal load only (see [Clause 5](#)) is the standard method.

The test method in which combined normal and shear loads are applied (see [Clause 6](#)) is intended for products that are sensitive to shear failure, i.e. which have a columnar or cusped structure.

The tests are carried out on dry specimens or on specimens immersed in water. The test is intended to be carried out with the specimen immersed in water when any part of the geosynthetic product contains a hydrophilic polymer.

2 Normative references

The following documents are referred to in the text in such a way that some or all of their content constitutes requirements of this document. For dated references, only the edition cited applies. For undated references, the latest edition of the referenced document (including any amendments) applies.

ISO 554, *Standard atmospheres for conditioning and/or testing — Specifications*

ISO 3696, *Water for analytical laboratory use — Specification and test methods*

ISO 9862, *Geosynthetics — Sampling and preparation of test specimens*

ISO 9863-1, *Geosynthetics — Determination of thickness at specified pressures — Part 1: Single layers*

ISO 10318-1, *Geosynthetics — Part 1: Terms and definitions*

3 Terms and definitions

For the purposes of this document, the terms and definitions given in ISO 10318-1 and the following apply.

ISO and IEC maintain terminological databases for use in standardization at the following addresses:

- ISO Online browsing platform: available at <https://www.iso.org/obp>
- IEC Electropedia: available at <http://www.electropedia.org/>

3.1

thickness

d

distance between the two rigid plates in contact with the specimen at any stage of the test

Note 1 to entry: See [Figures 1](#) and [2](#).

Note 2 to entry: Thickness is measured in millimetres.

**3.2
initial thickness**

d_i
thickness (3.1) of the specimen under an applied normal stress of 2 kPa

Note 1 to entry: Initial thickness is measured in millimetres, in accordance with ISO 9863-1.

**3.3
initial compressed thickness**

d_0
thickness (3.1) measured 1 min after loading (normal loading) or 4 min after loading (combined normal and shear loading)

**3.4
total compressive strain**

ε
time-dependent change in *thickness* (3.1)

Note 1 to entry: Total compressive strain is expressed as a percentage of the initial thickness, d_i .

**3.5
compressive creep strain**

ε_{cc}
time-dependant change in *thickness* (3.1) of a material subjected to a constant compressive load (after reaching the *initial compressed thickness* (3.3), d_0 , of the specimen)

Note 1 to entry: Compressive creep strain is expressed as a percentage of the initial compressed thickness, d_0 .

**3.6
compressive creep collapse**

occurrence of a sudden increase in the speed of change of *thickness* (3.1) of a specimen subjected to a constant compressive load

**3.7
machine direction**

MD
direction of manufacture of a geosynthetic product (the warp direction for woven geotextiles)

**3.8
cross-machine direction**

CMD
direction perpendicular to the direction of manufacture of a geosynthetic product (the weft direction for woven geotextiles)

4 Test specimens

4.1 Sampling

Specimens shall be taken in accordance with ISO 9862.

4.2 Number and dimensions of test specimens

Cut two specimens from the test sample for each test load; a new specimen is required for each test.

Each specimen shall satisfy the following criteria with regard to dimensions:

- the specimen shall be square and have a minimum size of 100 mm × 100 mm (see [Figures 1](#) and [2](#));

- if the specimen has a structure in which loading is resisted at defined points or areas, then the loading plate shall cover at least three complete points or areas in both directions (see [Figure 1](#) and [Figure 3 a\)](#))
- if the specimen has a structure in which loading is resisted at defined lines, then the specimen shall have a minimum of three contact lines on top loading plate and at least four complete lines on the fixed base plate (see [Figure 2](#) and [Figure 3 b\)](#));
- specimens shall be cut with the sides parallel in MD and CMD of the sample. MD and CMD direction shall be indicated on the sample.

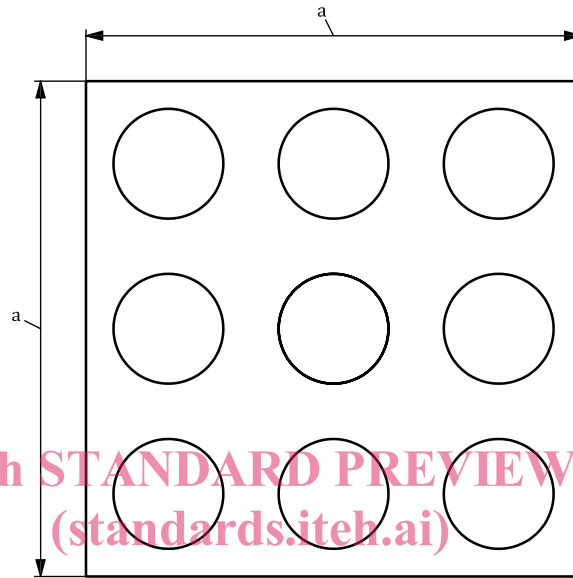

a) Plan view of the specimen, with indication of defined points or areas where loading is resisted

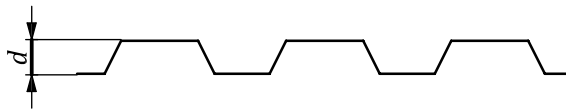

b) Cross-section of the specimen

Key

d thickness of the specimen, in millimetres

^a 100 mm minimum, or at least three contact points in each direction.

Figure 1 — Dimensions of general test specimen

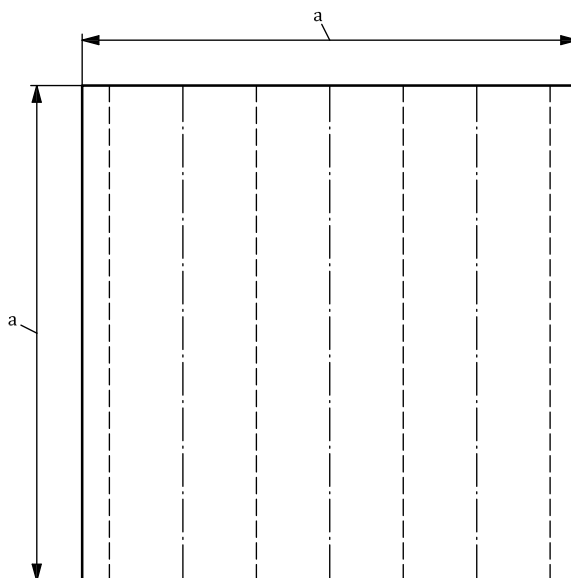

a) Plan view of the specimen, with indication of defined lines where loading is resisted

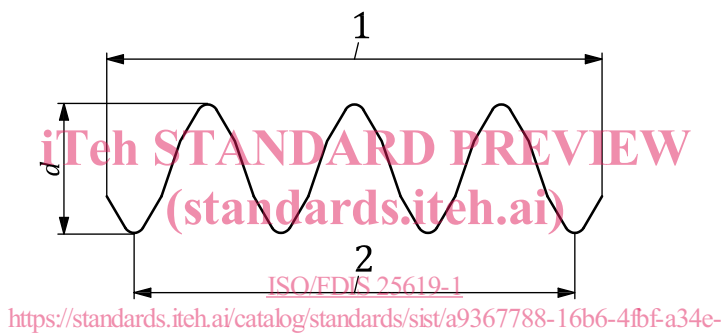

b) Cross-section of the specimen

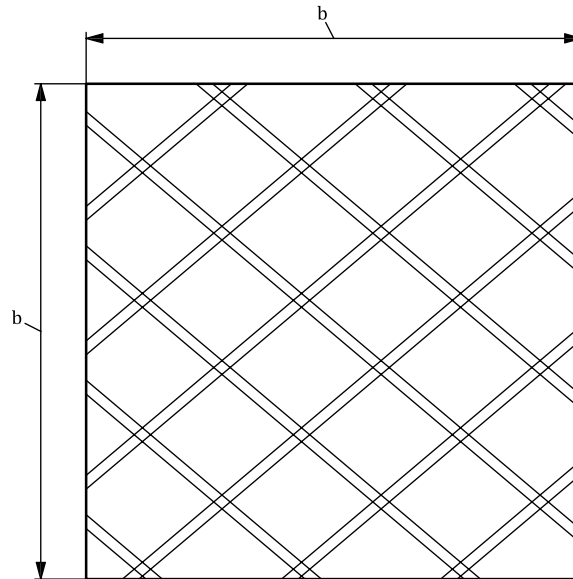

c) Plan view of the specimen, with structure in which loading is resisted at defined lines in diagonal directions

Key

- 1 specimen width
- 2 representative width of the specimen
- d thickness of specimen, in millimetres
- a 100 mm minimum, or a minimum of three contact lines on the top plate and a minimum of four contact lines on the base plate.
- b 100 mm minimum, or a minimum of three ribs connecting each side to the perpendicular side, for each set of ribs.

STANDARD PREVIEW
(standards.iteh.ai)
ISO/FDIS 25619-1
<https://standards.iteh.ai/catalog/standards/sist/a9367788-16b6-4bf-a34e-b0f86ceaf52c/iso-fdis-25619-1>

Figure 2 — Size of specimen with a structure in which loading is resisted at defined lines in MD or CMD direction, or with a structure in which loading is resisted at defined lines in diagonal directions

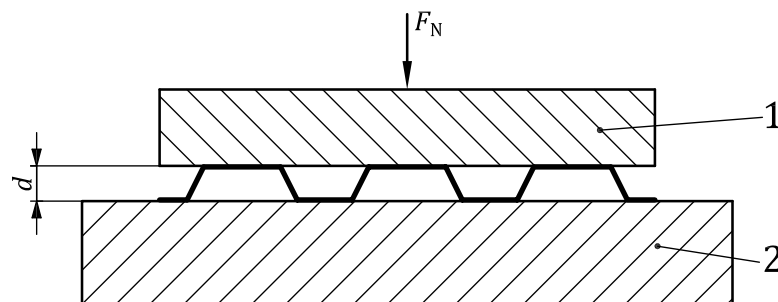

a) Example for a specimen with a structure in which loading is resisted at defined points or areas

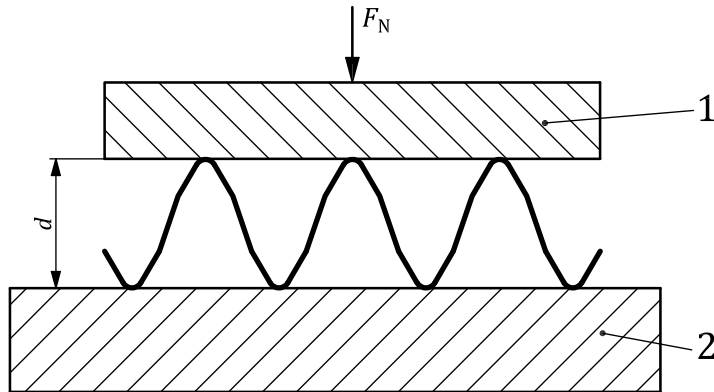

b) Example for a specimen with a structure in which loading is resisted at defined lines in MD or CMD direction

Key

- 1 metal top plate, smooth surface (same size as specimen or larger)
- 2 metal base plate, smooth surface (larger than top plate)
- d thickness of specimen, in millimetres
- F_N applied normal force, in kilonewtons

Figure 3 — Loading arrangements for structured cores

iTeh STANDARD PREVIEW
(standards.iteh.ai)

4.3 Conditioning

The test specimens shall be conditioned and tested in the standard atmosphere for testing at $(20 \pm 2) ^\circ\text{C}$ and $(65 \pm 5) \%$ relative humidity, as defined in ISO 554.

The specimens can be considered to have been conditioned when the change in mass in successive weighings made at intervals of not less than 2 h does not exceed 0,25 % of the mass of the test specimen.

Conditioning and/or testing in the standard atmosphere may only be omitted when it can be shown that results obtained for the same specific type of product (both structure and polymer type) are not affected by changes in temperature and humidity exceeding the limits. This information shall be included in the test report.

The test shall be carried out with the specimen immersed in water when any part of the geosynthetic product contains a hydrophilic polymer (see Figure 5). Where the test is to be carried out with the specimen immersed in water, the specimen shall be soaked in water for 24 h prior to the test. Deionized water in accordance with ISO 3696 shall be used. The water shall be maintained at a temperature of $(20 \pm 2) ^\circ\text{C}$.

5 Normal compressive load method

5.1 Principle

The geosynthetic specimen is placed on the fixed base plate of the compression testing equipment. With an upper loading plate, the vertical compressive load is applied and the change in thickness is recorded with time.

The vertical compressive load is applied to the specimen for a period of 1 000 h, or for a longer or shorter period by agreement.

5.2 Apparatus

5.2.1 Compression testing equipment.

Compression testing equipment with a vertical travel greater than the initial thickness of the specimen shall be used. It shall be capable of sustaining the applied stress to within 1 % accuracy for the duration of the test.

The compressive stress may be applied by a system capable to maintain a constant load for the duration of the test. The loading device, shall be capable of applying the full stress in one controlled step, i.e. without significant impact, within a period of 60 s.

In systems using dead weights, the loading system shall be fully supported while being assembled so that no forces are applied to the specimen until the support is smoothly released [see [Figure 4](#)].

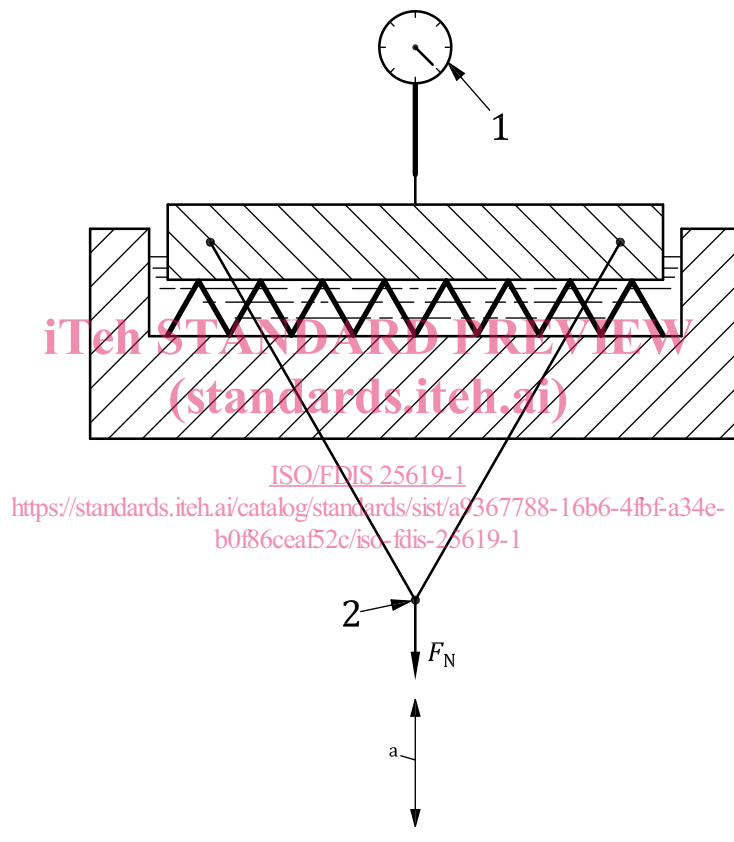

Key

- 1 thickness measuring device
- 2 weights on hanger
- F_N applied normal force, in kilonewtons
- ^a Load supported prior to starting.

Figure 4 — Examples of typical arrangements for normal load tests