

FINAL
DRAFT

INTERNATIONAL
STANDARD

ISO/FDIS
12643-5

ISO/TC 130

Secretariat: SAC

Voting begins on:
2023-08-23

Voting terminates on:
2023-10-18

Graphic technology — Safety requirements for graphic technology equipment and systems —

Part 5: Manually-fed stand-alone platen presses

Technologie graphique — Exigences de sécurité pour les systèmes et l'équipement de technologie graphique —

Partie 5: Presses à plateaux autonomes manuelles

ISO/FDIS 12643-5

<https://standards.iteh.ai/catalog/standards/sist/cc807ada-99dc-4404-8dc1-8e4b3e607651/iso-fdis-12643-5>

ISO/CEN PARALLEL PROCESSING

RECIPIENTS OF THIS DRAFT ARE INVITED TO SUBMIT, WITH THEIR COMMENTS, NOTIFICATION OF ANY RELEVANT PATENT RIGHTS OF WHICH THEY ARE AWARE AND TO PROVIDE SUPPORTING DOCUMENTATION.

IN ADDITION TO THEIR EVALUATION AS BEING ACCEPTABLE FOR INDUSTRIAL, TECHNOLOGICAL, COMMERCIAL AND USER PURPOSES, DRAFT INTERNATIONAL STANDARDS MAY ON OCCASION HAVE TO BE CONSIDERED IN THE LIGHT OF THEIR POTENTIAL TO BECOME STANDARDS TO WHICH REFERENCE MAY BE MADE IN NATIONAL REGULATIONS.



Reference number
ISO/FDIS 12643-5:2023(E)

© ISO 2023

iTeh STANDARD PREVIEW
(standards.iteh.ai)

ISO/FDIS 12643-5

<https://standards.iteh.ai/catalog/standards/sist/cc807ada-99dc-4404-8dc1-8e4b3e607651/iso-fdis-12643-5>



COPYRIGHT PROTECTED DOCUMENT

© ISO 2023

All rights reserved. Unless otherwise specified, or required in the context of its implementation, no part of this publication may be reproduced or utilized otherwise in any form or by any means, electronic or mechanical, including photocopying, or posting on the internet or an intranet, without prior written permission. Permission can be requested from either ISO at the address below or ISO's member body in the country of the requester.

ISO copyright office
CP 401 • Ch. de Blandonnet 8
CH-1214 Vernier, Geneva
Phone: +41 22 749 01 11
Email: copyright@iso.org
Website: www.iso.org

Published in Switzerland

Contents

Page

Foreword	iv
Introduction	vi
1 Scope	1
2 Normative references	1
3 Terms and definitions	2
4 Safeguarding of significant hazards	3
4.1 General safeguarding requirements.....	3
4.2 Safeguarding side access.....	4
4.3 Safeguarding front access.....	11
4.4 Access detection using laser scanners.....	11
4.5 Access and presence detection using vision based protective devices (VBPD).....	13
4.6 Platen presses with dwell mode (timer-controlled operation).....	15
4.7 Stopping distance and performance.....	15
4.8 Main drive braking and clutch/brake mechanism.....	15
4.9 Flywheels.....	16
4.10 Controls.....	16
4.10.1 Emergency stop pushbutton.....	16
4.10.2 Other controls.....	16
4.11 Safety related stop.....	16
4.12 Signals and warning devices — Indicator light for dwell mode.....	16
5 Verification of safety requirements and/or protective measures	16
6 Contents of instruction handbook	17
Annex A (informative) List of significant hazards	18
Bibliography	19

Foreword

ISO (the International Organization for Standardization) is a worldwide federation of national standards bodies (ISO member bodies). The work of preparing International Standards is normally carried out through ISO technical committees. Each member body interested in a subject for which a technical committee has been established has the right to be represented on that committee. International organizations, governmental and non-governmental, in liaison with ISO, also take part in the work. ISO collaborates closely with the International Electrotechnical Commission (IEC) on all matters of electrotechnical standardization.

The procedures used to develop this document and those intended for its further maintenance are described in the ISO/IEC Directives, Part 1. In particular, the different approval criteria needed for the different types of ISO document should be noted. This document was drafted in accordance with the editorial rules of the ISO/IEC Directives, Part 2 (see www.iso.org/directives).

ISO draws attention to the possibility that the implementation of this document may involve the use of (a) patent(s). ISO takes no position concerning the evidence, validity or applicability of any claimed patent rights in respect thereof. As of the date of publication of this document, ISO had not received notice of (a) patent(s) which may be required to implement this document. However, implementers are cautioned that this may not represent the latest information, which may be obtained from the patent database available at www.iso.org/patents. ISO shall not be held responsible for identifying any or all such patent rights.

Any trade name used in this document is information given for the convenience of users and does not constitute an endorsement.

For an explanation of the voluntary nature of standards, the meaning of ISO specific terms and expressions related to conformity assessment, as well as information about ISO's adherence to the World Trade Organization (WTO) principles in the Technical Barriers to Trade (TBT), see www.iso.org/iso/foreword.html.

This document was prepared by Technical Committee ISO/TC 130, *Graphic technology*, in collaboration with the European Committee for Standardization (CEN) Technical Committee CEN/TC 198, *Printing and paper machinery — Safety*, in accordance with the Agreement on technical cooperation between ISO and CEN (Vienna Agreement).

This second edition cancels and replaces the first edition (ISO 12643-5:2010), which has been technically revised.

The main changes are as follows:

- in [Clause 3](#), definitions for different operation modes (single stroke mode, dwell mode, continuous operation mode) have been added;
- in [4.2](#), figures showing examples for safeguarding side access have been included;
- in [4.3](#), the requirements for safeguarding access from the front side have been revised, differentiating the requirements for small platen presses with a table width less than or equal to 1 m and large ones with a table width wider than 1 m;
- in [4.4](#), requirements for the positioning of laser scanners have been included;
- in [4.5](#), requirements when using vision based protective devices (VBPD) for the detection of persons on the platen, including calculation of the safety distance have been included;
- in [4.6](#), the requirements for timer controlled operation have been revised;
- in [4.7](#), the requirements for stopping distance and performance have been revised;
- in [Clause 6](#), requirements for the content of the instruction handbook have been added;

— the list of significant hazards has been moved to an informative [Annex A](#).

This document is intended to be used in conjunction with ISO/FDIS 12643-1:2023.

A list of all parts in the ISO 12643 series can be found on the ISO website.

Any feedback or questions on this document should be directed to the user's national standards body. A complete listing of these bodies can be found at www.iso.org/members.html.

iTeh STANDARD PREVIEW (standards.iteh.ai)

ISO/FDIS 12643-5

<https://standards.iteh.ai/catalog/standards/sist/cc807ada-99dc-4404-8dc1-8e4b3e607651/iso-fdis-12643-5>

Introduction

This document is a type-C standard as stated in ISO 12100:2010.

This document is of relevance, in particular, for the following stakeholder groups representing the market players with regard to machinery safety:

- machine manufacturers (small, medium and large enterprises);
- health and safety bodies (regulators, accident prevention organisations, market surveillance, etc.)

Others can be affected by the level of machinery safety achieved with the means of the document by the above-mentioned stakeholder groups:

- machine users/employers (small, medium and large enterprises);
- machine users/employees (e.g. trade unions, organizations for people with special needs);
- service providers, e. g. for maintenance (small, medium and large enterprises);
- consumers (in case of machinery intended for use by consumers).

The above-mentioned stakeholder groups have been given the possibility to participate at the drafting process of this document.

The machinery concerned and the extent to which hazards, hazardous situations or hazardous events are covered are indicated in the Scope of this document.

During the development of this document, existing relevant standards of other countries were taken into consideration. In cases where it was known that there is a national requirement that differs from this document, that has been noted.

This document was developed to harmonize the following US and European safety standards:

- ANSI B65-5^[1],
- EN 1010-5^[2].

When requirements of this type-C standard are different from those which are stated in type-A or type-B standards, the requirements of this type-C standard take precedence over the requirements of the other standards for machines that have been designed and built according to the requirements of this type-C standard.

The full set of requirements for graphic technology equipment and systems are those given in the part of ISO 12643 applicable to that type, together with the relevant requirements from ISO/FDIS 12643-1:2023, to the extent specified in the Scope of the applicable part of ISO 12643.

This document supplements and modifies the general requirements of ISO/FDIS 12643-1:2023. Where a requirement of this document conflicts with a requirement of ISO/FDIS 12643-1:2023 the requirement of this document will take precedence.

Graphic technology — Safety requirements for graphic technology equipment and systems —

Part 5: Manually-fed stand-alone platen presses

1 Scope

This document provides safety requirements specific to stand-alone platen presses.

This document provides additional safety requirements for the design and construction of manually-fed stand-alone platen presses, for single stroke mode, dwell mode, and continuous operation mode for cutting and creasing, embossing, foil stamping and/or printing of paper, board and other materials processed in a similar manner.

This document does not apply to presses designed to handle metal material other than foil.

2 Normative references

The following documents are referred to in the text in such a way that some or all of their content constitutes requirements of this document. For dated references, only the edition cited applies. For undated references, the latest edition of the referenced document (including any amendments) applies.

ISO 4413:2010, *Hydraulic fluid power — General rules and safety requirements for systems and their components*

ISO 4414:2010, *Pneumatic fluid power — General rules and safety requirements for systems and their components*

ISO 12100:2010, *Safety of machinery — General principles for design — Risk assessment and risk reduction*

ISO/FDIS 12643-1:2023, *Graphic technology — Safety requirements for graphic technology equipment and systems — Part 1: General requirements*

ISO 13849-1:2015, *Safety of machinery — Safety-related parts of control systems — Part 1: General principles for design*

ISO 13850:2015, *Safety of machinery — Emergency stop function — Principles for design*

ISO 13855:2010, *Safety of machinery — Positioning of safeguards with respect to the approach speeds of parts of the human body*

ISO 13856-2:2013, *Safety of machinery — Pressure-sensitive protective devices — Part 2: General principles for design and testing of pressure-sensitive edges and pressure-sensitive bars*

ISO 13857:2019, *Safety of machinery — Safety distances to prevent hazard zones being reached by upper and lower limbs*

ISO 14120:2015, *Safety of machinery — Guards — General requirements for the design and construction of fixed and movable guards*

IEC 61496-1:2020, *Safety of machinery — Electro-sensitive protective equipment — Part 1: General requirements and tests*

IEC 61496-3:2018, *Safety of machinery — Electro-sensitive protective equipment — Part 3:Particular requirements for active opto-electronic protective devices responsive to diffuse reflection (AOPDDR)*

IEC/TS 61496-4-3:2015, *Safety of machinery — Electro-sensitive protective equipment — Part 4-3: Particular requirements for equipment using vision based protective devices (VBPD) — Additional requirements when using stereo vision techniques (VBPST)*

IEC 62061:2021, *Safety of machinery — Functional safety of safety-related electrical, electronic and programmable electronic control systems*

3 Terms and definitions

For the purposes of this document, the terms and definitions given in ISO/FDIS 12643-1:2023 and the following apply.

ISO and IEC maintain terminological databases for use in standardization at the following addresses:

- ISO Online browsing platform: available at <https://www.iso.org/obp>
- IEC Electropedia: available at <https://www.electropedia.org/>

3.1
protective device
safeguard other than a guard

Note 1 to entry: Examples of protective devices include, but are not limited to, hold-to-run controls, two-hand controls, ESPDs, etc.

3.2
trip bar
knee bar
protective bar that, when pushed, activates the interlocking safety system of the machine

Note 1 to entry: A trip bar can be a metal bar or a pressure sensitive edge.

3.3
stand-alone platen press
self-contained machine not intended to be used as part of an integrated manufacturing system

3.4
single stroke mode
operation mode of platen presses in which the movable platen is operator activated for each stroke

3.5
dwelling mode
operation mode of platen presses in which the movable platen operates with time-controlled operation before each stroke with a time delay pre-set by the operator

3.6
continuous operation mode
operation mode of platen presses in which the movable platen operates each stroke without any time delay between preceding and following stroke

3.7
width
<platen press> outer dimension of the movable platen table on the operator side

Note 1 to entry: See [Figure 1](#).

3.8 depth

<platen press> dimension from the outer edge of the movable platen table on the operator's side to the die cutting plane when fully open

Note 1 to entry: Note to entry See [Figure 1](#).

4 Safeguarding of significant hazards

4.1 General safeguarding requirements

Safeguarding shall be provided in those areas where it is recognized that operators are exposed to significant hazards. The guarding requirements of ISO/FDIS 12643-1:2023 apply. Guard construction shall meet the requirements as specified in ISO 14120:2015. All manually-fed stand-alone platen presses with a table width less than or equal to 1 m and with a table depth less than or equal to 850 mm shall have trip bar(s) or other protective devices in accordance with [4.3](#) and located where access to a hazard is possible.

For platen presses greater than 1 m width and where the depth of the platen table is longer than 850 mm U-shaped trip bars are not accepted as the only safeguard. In this case, presence detection, such as electro-sensitive protective device (ESPD), shall be provided.

The hazards created by the movable platen shall be guarded by the use of an interlocking knee bar (see [Figure 1](#), key item 7) and a U-shaped trip bar (see [Figure 1](#), key item 2).

The length of the knee bar shall be equal to or greater than the width of the movable platen. The knee bar shall be constructed such that it will retain its shape to ensure actuation of the trip function throughout its length. With the movable platen in the open position, the clearance between the knee bar and front surface of the movable platen shall be at least 120 mm. (see [Figure 1](#), key item 7).

On platen presses with a table width greater than 1 m presence detection shall detect anyone on the bed of the movable platen and prevent start-up when the presence of a person is detected, and the platen press is stopped. Further movement shall require the operation of a reset control and a separate manual restart.

Presence detection can be by means of (a) laser scanner(s), vision based protective devices (VBPD) or another equally effective electro-sensitive protective device(s) (ESPD).

All mechanical trip bars shall be provided with a switch mounted on each end of the trip bar.

Trip functions using mechanical devices (including knee bars) shall satisfy the requirements of ISO 13856-2:2013 and PL e of ISO 13849-1:2015 or SIL 3 of IEC 62061:2021. Trip functions or presence sensing functions using laser scanners, VBPD or light curtains shall satisfy the requirements of PL d of ISO 13849-1:2015 or SIL 2 of IEC 62061:2021.

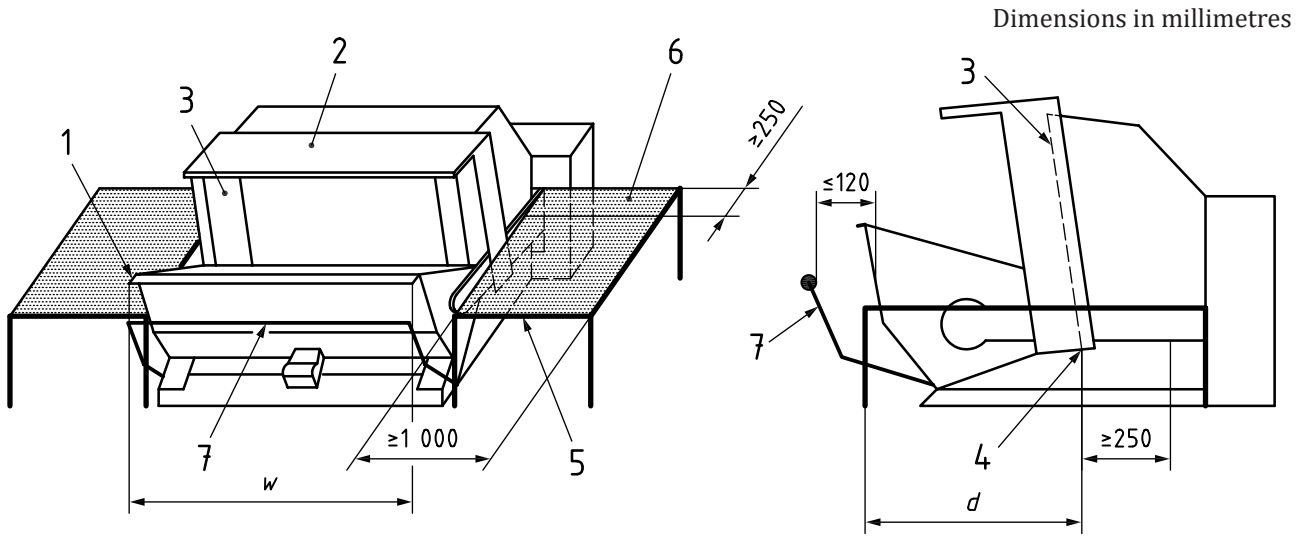

Key

- | | | | |
|---|-----------------------------------|---|-----------------------|
| 1 | trip bar on movable platen | 6 | Interlocking table |
| 2 | U-shaped trip bar on fixed platen | 7 | knee bar |
| 3 | fixed platen | w | width of platen press |
| 4 | lower edge of fixed platen | d | depth of platen press |
| 5 | front edge of interlocking table | | |

Figure 1 — Trip bars, interlocking tables and position of knee bar

4.2 Safeguarding side access

The access from the side of the platen press shall be prevented. This can be realized by one or a combination of the following measures:

- a) interlocking tables that prevent access, from either side of the press according to ISO 13857:2019, Tables 2 and 4. See [Figure 2](#) and [Figure 3](#).

The minimum height of the tables shall be 1 000 mm. The tables shall be designed in such a way that it prevents a person crawling underneath or climbing on top of the table. This can be achieved, for example, by completely covering the sides of the tables.

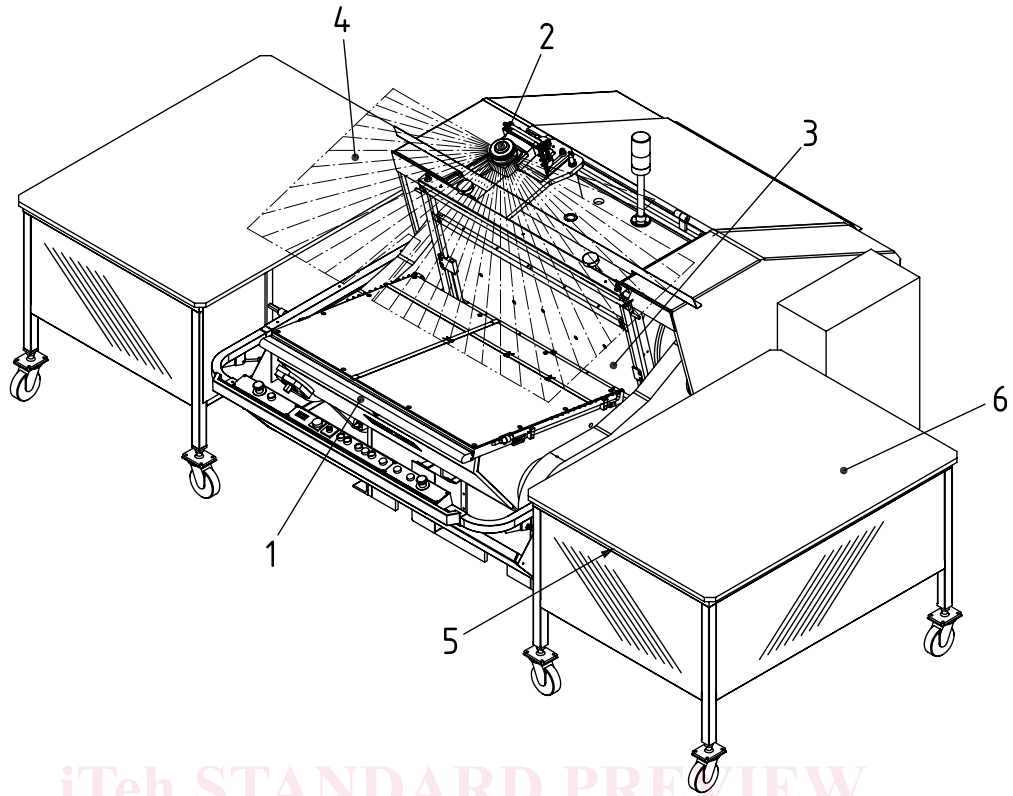

Key

- | | | | |
|---|----------------------------|---|----------------------------------|
| 1 | trip bar on movable platen | 4 | scanned area on the top |
| 2 | laser scanner on the top | 5 | front edge of interlocking table |
| 3 | fixed platen | 6 | interlocking table |

<https://standards.iteh.ai/catalog/standards/sist/cc807ada-99dc-4404-8dc1->

Figure 2 — Use of a combination of interlocked tables at the side and laser scanner on the top (personal detection device) to safeguard side access on platen presses with a table width greater than 1 m