**Auxiliary tables for vibration
generators — Methods of describing
equipment characteristics**

*Tables auxiliaires pour générateurs de vibrations — Méthodes de
description des caractéristiques*

iTeh Standards
(<https://standards.iteh.ai>)
Document Preview

[ISO 6070:2019](https://standards.iteh.ai/catalog/standards/iso/56fcdada-2efd-4717-9de1-604855a8c477/iso-6070-2019)

<https://standards.iteh.ai/catalog/standards/iso/56fcdada-2efd-4717-9de1-604855a8c477/iso-6070-2019>



iTeh Standards
(<https://standards.iteh.ai>)
Document Preview

ISO 6070:2019

<https://standards.iteh.ai/catalog/standards/iso/56fcdada-2efd-4717-9de1-604855a8c477/iso-6070-2019>



COPYRIGHT PROTECTED DOCUMENT

© ISO 2019

All rights reserved. Unless otherwise specified, or required in the context of its implementation, no part of this publication may be reproduced or utilized otherwise in any form or by any means, electronic or mechanical, including photocopying, or posting on the internet or an intranet, without prior written permission. Permission can be requested from either ISO at the address below or ISO's member body in the country of the requester.

ISO copyright office
CP 401 • Ch. de Blandonnet 8
CH-1214 Vernier, Geneva
Phone: +41 22 749 01 11
Fax: +41 22 749 09 47
Email: copyright@iso.org
Website: www.iso.org

Published in Switzerland

Contents

	Page
Foreword	v
1 Scope	1
2 Normative references	1
3 Terms and definitions	1
4 Symbols	2
5 Vibration values	3
6 Auxiliary table configurations	3
6.1 General	3
6.2 Typical designs of the head expander	4
6.2.1 General	4
6.2.2 Expander with linear bearing guidance and air spring support	5
6.2.3 Expander with hydrostatic bearing guidance and air spring supports	5
6.2.4 Bare head expander	5
6.3 Typical designs of the slip table	5
6.3.1 General	5
6.3.2 Hydrostatic bearing table	5
6.3.3 Flat spring table	6
6.3.4 Oil or air cushion table	6
6.3.5 Mechanical slide table	6
6.3.6 Ball, roller or needle bearing table	6
6.3.7 Hydraulic slide table	6
6.3.8 Magnetic bearing table	6
6.3.9 Dry bearing table with hydrostatic compensation	6
6.4 Axis systems	7
6.4.1 Moving table reference axis system	7
6.4.2 Other moving table reference axis systems	8
7 Auxiliary table characteristics	8
7.1 General	8
7.2 Characteristics	8
7.2.1 Effective travel	8
7.2.2 Rated frequency range	8
7.2.3 Rated RMS velocity v_z	8
7.2.4 Static load (limit) F_s	8
7.2.5 Static load (limit) per unit area F_p	8
7.2.6 Limiting axial forces	8
7.2.7 Limiting pitching torque C_α	8
7.2.8 Limiting rolling torque C_β	9
7.2.9 Limiting yawing torque C_γ	9
7.2.10 Transmissibility	9
7.2.11 Total harmonic distortion of acceleration	9
7.2.12 Environmental limits	9
7.2.13 Load mounting insert pattern	9
8 Test loads	10
9 Characteristics to be supplied by the manufacturer	10
10 Measurement of common dynamic characteristics	15
10.1 Plotting of the acceleration transmissibility function	15
10.2 Measurement of transverse accelerations	15
10.2.1 No-load condition	15
10.2.2 Loaded condition	15
10.3 Measurement of test table acceleration field uniformity	16
10.4 Measurement of acceleration distortion	16

10.5	Measurement of parasitic rotations.....	16
11	Operating instructions	16
	Bibliography	18

iTeh Standards
(<https://standards.itih.ai>)
Document Preview

[ISO 6070:2019](https://standards.itih.ai/catalog/standards/iso/56fcdada-2efd-4717-9de1-604855a8c477/iso-6070-2019)

<https://standards.itih.ai/catalog/standards/iso/56fcdada-2efd-4717-9de1-604855a8c477/iso-6070-2019>

Foreword

ISO (the International Organization for Standardization) is a worldwide federation of national standards bodies (ISO member bodies). The work of preparing International Standards is normally carried out through ISO technical committees. Each member body interested in a subject for which a technical committee has been established has the right to be represented on that committee. International organizations, governmental and non-governmental, in liaison with ISO, also take part in the work. ISO collaborates closely with the International Electrotechnical Commission (IEC) on all matters of electrotechnical standardization.

The procedures used to develop this document and those intended for its further maintenance are described in the ISO/IEC Directives, Part 1. In particular, the different approval criteria needed for the different types of ISO documents should be noted. This document was drafted in accordance with the editorial rules of the ISO/IEC Directives, Part 2 (see www.iso.org/directives).

Attention is drawn to the possibility that some of the elements of this document may be the subject of patent rights. ISO shall not be held responsible for identifying any or all such patent rights. Details of any patent rights identified during the development of the document will be in the Introduction and/or on the ISO list of patent declarations received (see www.iso.org/patents).

Any trade name used in this document is information given for the convenience of users and does not constitute an endorsement.

For an explanation of the voluntary nature of standards, the meaning of ISO specific terms and expressions related to conformity assessment, as well as information about ISO's adherence to the World Trade Organization (WTO) principles in the Technical Barriers to Trade (TBT) see www.iso.org/iso/foreword.html.

This document was prepared by Technical Committee ISO/TC 108, *Mechanical vibration, shock and condition monitoring*, Subcommittee SC 6, *Vibration and shock generating systems*.

This second edition cancels and replaces the first edition (ISO 6070:1981), which has been technically revised. It also incorporates the Corrigendum ISO 6070:1981/Cor 1:2006. The main changes compared to the previous edition are as follows:

— Consideration of one more type of auxiliary table, the head expander.

Any feedback or questions on this document should be directed to the user's national standards body. A complete listing of these bodies can be found at www.iso.org/members.html.

Auxiliary tables for vibration generators — Methods of describing equipment characteristics

1 Scope

This document establishes requirements to ensure appropriate exchange of information between manufacturers and users of auxiliary tables with a view to working out related specifications and possibly to comparing, in an objective way, the characteristics supplied by the manufacturers of auxiliary tables and associated guidance systems.

This document is applicable to auxiliary tables which include slip tables and head expanders. It does not cover auxiliary tables with several degrees of freedom.

This document provides three levels of description of the test equipment, as follows:

- a) minimum level;
- b) medium level;
- c) high level.

This document gives a list of characteristics to be specified for each level of description.

2 Normative references

The following documents are referred to in the text in such a way that some or all of their content constitutes requirements of this document. For dated references, only the edition cited applies. For undated references, the latest edition of the referenced document (including any amendments) applies.

ISO 2041, *Mechanical vibration, shock and condition monitoring — Vocabulary*

ISO 15261, *Vibration and shock generating systems — Vocabulary*

3 Terms and definitions

For the purpose of this document, the terms and definitions given in ISO 2041 and ISO 15261 and the following apply.

ISO and IEC maintain terminological databases for use in standardization at the following addresses:

- ISO Online browsing platform: available at <https://www.iso.org/obp>
- IEC Electropedia: available at <http://www.electropedia.org/>

3.1

slip table

auxiliary table connected to one or several vibration generators working along axes which are parallel to the longitudinal axis of the table

Note 1 to entry: A slip table is normally used to conduct horizontal vibration test.

Note 2 to entry: See 6.4.1 for the coordinates of a slip table.

**3.2
head expander**

auxiliary table connected to one or several vibration generators working along axes which are in line with the normal axis of the table

Note 1 to entry: A head expander is normally used to conduct vertical vibration test.

Note 2 to entry: See [6.4.1](#) for the coordinates of a head expander.

4 Symbols

C_α	Limiting pitching torque
C_β	Limiting rolling torque
C_γ	Limiting yawing torque
d	Total harmonic distortion of acceleration
F_a	Force measured in direction z to overcome static friction (stiction)
F_g	Force measured in direction z to overcome dynamic friction
F_s	Static load limit
F_p	Static load limit per unit area
F_x, F_y, F_z	Limiting forces which can be withstood by the moving auxiliary table along the three axes
f	Frequency
f_{\max}	Maximum operational frequency
f_{\min}	Minimum operational frequency
g_n	Standard acceleration due to gravity (according to ISO 2041, g_n equals 9,806 65 m/s ²)
I_x, I_y, I_z	Moments of inertia of the moving table with respect to axes parallel to the reference axes through the centre of gravity
K_x, K_y, K_z	Translational stiffness of guidance system along the three axes
$K_\alpha, K_\beta, K_\gamma$	Rotational stiffness of guidance about the three axes
m	Total mass of moving table including moving components of guidance system
m_t	Test load (subscript "t" may be 0, 1, 4, 10, 20, or 40; see Clause 8)
v_z	Rated RMS velocity along z axis
X_C, Y_C, Z_C	Coordinates of centre of test table surface (see 6.4.1 , Figure 3)
X_G, Y_G, Z_G	Coordinates of moving table centre of gravity
α	Pitch angle (rotation about y axis)
β	Roll angle (rotation about z axis for slip tables and about x axis for head expanders)
γ	Yaw angle (rotation about x axis for slip tables and about z axis for head expanders)

5 Vibration values

When the manufacturer, or user, specifies values for the parameters required in this document, it shall be clearly defined, where applicable, whether vibration is expressed in terms of RMS, peak or peak-to-peak values.

6 Auxiliary table configurations

6.1 General

An auxiliary table is a mechanical system intended for transmitting vibration generated by one or more vibration generators to equipment under test.

The table is fitted with its own guidance system (if necessary), which shall be compatible with the guidance system of the vibration generator(s).

This document deals with auxiliary tables of two common types:

- head expanders, used to transfer vertical vibration (see [Figure 1](#));

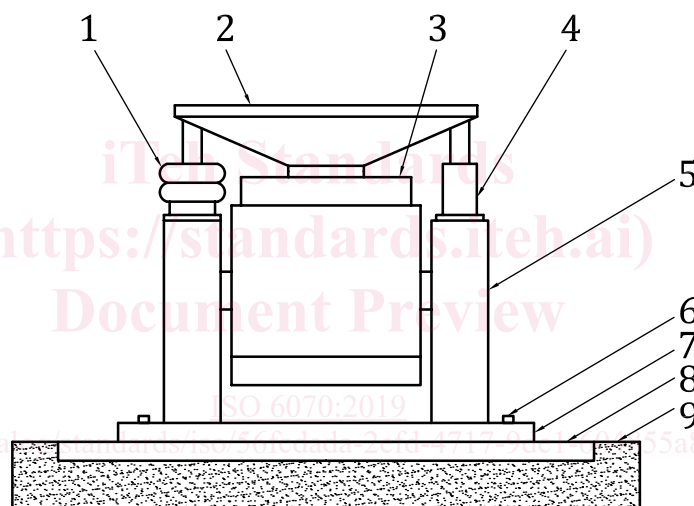

Key

1	load support system	6	screws connecting the vibration generator to the foundation
2	head expander	7	vibration generator bottom plate
3	vibration generator	8	foundation plate
4	guidance system	9	foundation
5	trunnion support		

Figure 1 — Example of coupling of a head expander to single vibration generator (typical configuration)

- slip tables, used to transfer horizontal vibration (see [Figure 2](#)).

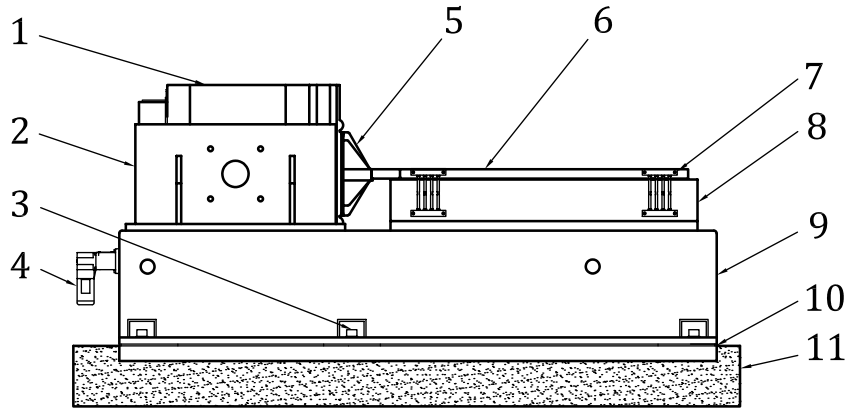

Key

- | | | | |
|---|---|----|-----------------------------|
| 1 | vibration generator | 6 | slip plate |
| 2 | trunnion support | 7 | centring device |
| 3 | screws connecting the vibration generator to the foundation | 8 | guidance and support system |
| 4 | rotation device | 9 | Pedestal |
| 5 | driver bar | 10 | foundation plate |
| | | 11 | Foundation |

Figure 2 — Example of coupling of an auxiliary table to single vibration generator (typical configuration)

The head expander is mainly composed of:

- the moving table;
- the guidance system (optional);
- the support system (optional).

Optionally, the head expander can be equipped with a lifting device which lifts the head expander assembly, normally with air or hydraulic cylinder, and allows rotation of the vibration generator to the horizontal direction without removing the expander assembly.

The head expander can be either of square or round shape.

The slip table is mainly composed of:

- the moving table;
- the driver bar;
- the guidance and support system.

6.2 Typical designs of the head expander

6.2.1 General

Typical designs of the head expander are given in [6.2.2](#) to [6.2.4](#).

To achieve a higher load and overturning moment capacity, guidance and support systems are normally used.