



Designation: ~~D3801-06~~ Designation: D3801 - 10

## Standard Test Method for Measuring the Comparative Burning Characteristics of Solid Plastics in a Vertical Position<sup>1</sup>

This standard is issued under the fixed designation D3801; the number immediately following the designation indicates the year of original adoption or, in the case of revision, the year of last revision. A number in parentheses indicates the year of last reapproval. A superscript epsilon ( $\epsilon$ ) indicates an editorial change since the last revision or reapproval.

### 1. Scope\*

1.1 This fire-test-response standard covers a small-scale laboratory procedure for determining comparative burning characteristics of solid-plastic material, using a 20-mm (50W) premixed flame applied to the base of specimens held in a vertical position.

NOTE 1—This test method and the 20 mm (50W) Vertical Burning Test (V-0, V-1, or V-2) of ANSI/UL 94 are equivalent.

NOTE 2—This test method and Test Method B of IEC 60695-11-10 are equivalent. IEC 60695-11-10 has replaced ISO 1210.

NOTE 3—For additional information on materials that burn up to the holding clamp by this test method, see Test Method D635. For test methods of flexible plastics in the form of thin sheets and film, see Test Method D4804. For additional information on comparative burning characteristics and resistance to burn-through, see Test Method D5048.

1.2 This test method was developed for polymeric materials used for parts in devices and appliances. The results are intended to serve as a preliminary indication of their acceptability with respect to flammability for a particular application. The final acceptance of the material is dependent upon its use in complete equipment that conforms with the standards applicable to such equipment.

1.3 The classification system described in the appendix is intended for quality assurance and the preselection of component materials for products.

1.4 It is possible that this test is applicable to nonmetallic materials other than plastics. Such application is outside the scope of this technical committee.

1.5 This test method does not cover plastics when used for building construction, finishing or contents such as wall and floor coverings, furnishings, decorative objects etc. In addition, the fire resistance (in terms of an hourly rating), flame spread, smoke characterization and heat release rate are not evaluated by this test. Other fire tests exist and shall be used to evaluate the flammability of materials in these intended end use product configuration.

~~1.6 The values stated in SI units are to be regarded as standard.~~

1.6 The values stated in SI units are to be regarded as standard. No other units of measurement are included in this standard.

1.7 *This standard is used to measure and describe the response of materials, products, or assemblies to heat and flame under controlled conditions, but does not by itself incorporate all factors required for fire hazard or fire risk assessment of the materials, products, or assemblies under actual fire conditions.*

1.8 *This standard does not purport to address all of the safety concerns, if any, associated with its use. It is the responsibility of the user of this standard to establish appropriate safety and health practices and determine the applicability of regulatory limitations prior to use.*

### 2. Referenced Documents

2.1 ~~ASTM Standards:~~ ASTM Standards:<sup>2</sup>

D618 [Practice for Conditioning Plastics for Testing](#)

D635 [Test Method for Rate of Burning and/or Extent and Time of Burning of Plastics in a Horizontal Position](#)

D883 [Terminology Relating to Plastics](#)

D4804 [Test Method for Determining the Flammability Characteristics of Nonrigid Solid Plastics](#)

D5025 [Specification for Laboratory Burner Used for Small-Scale Burning Tests on Plastic Materials](#)

<sup>1</sup> This test method is under the jurisdiction of ASTM Committee D20 on Plastics and is the direct responsibility of Subcommittee D20.30 on Thermal Properties (Section D20.30.03).

Current edition approved Sept. 15, 2006. Published October 2006. Originally approved in 1987. Last previous edition approved in 2000 as D3801-00. DOI: 10.1520/D3801-06.

Current edition approved July 1, 2010. Published July 2010. Originally approved in 1987. Last previous edition approved in 2006 as D3801 - 06. DOI: 10.1520/D3801-10.

<sup>2</sup> For referenced ASTM standards, visit the ASTM website, [www.astm.org](http://www.astm.org), or contact ASTM Customer Service at [service@astm.org](mailto:service@astm.org). For *Annual Book of ASTM Standards* volume information, refer to the standard's Document Summary page on the ASTM website.

\*A Summary of Changes section appears at the end of this standard.

D5048 Test Method for Measuring the Comparative Burning Characteristics and Resistance to Burn-Through of Solid Plastics Using a 125-mm Flame

D5207 Practice for Confirmation of 20mm (50W) and 125mm (500W) Test Flames for Small-Scale Burning Tests on Plastic Materials

E176 Terminology of Fire Standards

E691 Practice for Conducting an Interlaboratory Study to Determine the Precision of a Test Method

2.2 IEC Standard:<sup>3</sup>

60695–11–10 Fire Hazard Testing—Part 11-10: Test Flames—50W Horizontal and Vertical Flame Test Methods

2.3 ISO Standard:<sup>3</sup>

ISO 1210 Plastics—Determination of the Burning Behaviour of Horizontal and Vertical Specimens in Contact with a Small-Flame Ignition Source (Withdrawn)

2.4 UL Standard:<sup>4</sup>

ANSI/UL 94 Test for Flammability of Plastic Materials for Parts in Devices and Appliances

### 3. Terminology

3.1 *Definitions*—For terms relating to plastics, the definitions in this test method are in accordance with Terminology D883. For terms relating to fire, the definitions used in this test method are in accordance with Terminology E176.

3.2 *Definitions of Terms Specific to This Standard:*

3.2.1 *afterflame*—persistence of flaming of a material, after the ignition source has been removed.

3.2.2 *afterflame time*—the length of time for which a material continues to flame, under specified conditions, after the ignition source has been removed.

3.2.3 *afterglow*—persistence of glowing of a material, after cessation of flaming or, if no flaming occurs, after removal of the ignition source.

3.2.4 *afterglow time*—the length of time for which a material continues to glow under specified test conditions, after the ignition source has been removed or cessation of flaming, or both.

3.2.5 *flame-impingement time*—the time in seconds that the flame from the burner is in contact with the specimen.

3.2.6 *flaming material*—flaming drips or particles from the specimen that ignite the absorbent 100 % cotton.

### 4. Summary of Test Method

4.1 The procedure consists of subjecting a set of pre-conditioned specimens of identical composition and geometry to a standard test flame for two 10-s flame applications. The afterflame time is recorded after the first flame application, and the afterflame and afterglow times are recorded after the second flame application. Information is also recorded on whether or not flaming material drips from the specimen (and whether these drips ignite a cotton indicator) and total flame time for a particular specimen set.

### 5. Significance and Use

5.1 The tests results represent afterflame and afterglow time in seconds for a material of specified shape, under the conditions of this test method.

5.2 The effect of material thickness, color additives, and possible loss of volatile components is measurable.

5.3 The results, when tabulated, are potentially useful as a reference for comparing the relative performance of materials and as an aid in material selection.

5.4 In this procedure, the specimens are subjected to one or more specific sets of laboratory test conditions. Different test conditions will likely result in changes in the fire-test-response characteristics measured. Therefore, the results are valid only for the fire-test-exposure conditions described in this test method.

### 6. Apparatus

6.1 *Test Chamber*, enclosed laboratory hood or chamber, having an inside volume of at least 0.5 m<sup>3</sup>. The chamber shall permit observation of tests in progress and shall be , free of induced or forced draft during test, while allowing normal thermal circulation of air past the test specimen during burning. The inside surfaces of the chamber shall be of a dark color. When a light meter, facing towards the rear of the chamber, is positioned in place of the test specimen, the recorded light level shall be less than 20 lx. For safety and convenience, it is desirable that this enclosure be fitted with an extraction device, such as an exhaust fan, to remove products of combustion. The extraction device shall be turned off during the test and turned on immediately after the test to remove the fire effluents. (**Warning**—Combustion products are toxic. A system to contain and remove the products of combustion after a test is required.)

NOTE 4—Laboratory hoods often have induced drafts even with the exhaust fan off. In such cases, a positive-closing damper shall be used.

<sup>3</sup> Publications of the International Electrotechnical Commission (IEC) and International Organization for Standardization (ISO) are available from American National Standards Institute (ANSI), 25 W. 43rd St., 4th Floor, New York, NY 10036, <http://www.ansi.org>.

<sup>4</sup> Available from Underwriters Laboratories (UL), 333 Pfingsten Rd., Northbrook, IL 60062-2096, <http://www.ul.com>.

NOTE 5—A mirror in the chamber, to provide a rear view of the specimen, has been found useful in some enclosures.

6.2 *Laboratory Burner*, constructed in accordance with Specification D5025.

6.3 *Ring Stand*, with a clamp or the equivalent, adjustable for vertical positioning of specimens.

6.4 *Gas Supply*, a supply of technical-grade methane gas, minimum 98 % pure, with suitable regulator and meter for uniform gas flow. Natural gas having an energy density of  $37 \pm 1 \text{ MJ/m}^3$  at  $25^\circ\text{C}$  has been found to provide similar results. However, technical-grade methane gas shall be used as the referee gas in cases of dispute.

6.5 *Timing Device*, accurate to 0.5 s.

6.6 *Cotton*, absorbent 100 % cotton.

6.7 *Desiccator*, containing anhydrous calcium chloride or other drying agent, capable of being maintained at  $23 \pm 2^\circ\text{C}$  and relative humidity not exceeding 20 %.

6.8 *Conditioning Room or Chamber*, capable of being maintained at  $23 \pm 2^\circ\text{C}$  and a relative humidity of  $50 \pm 5\%$ .

6.9 *Conditioning Oven*, a full-draft circulating-air oven capable of being maintained at  $70 \pm 2^\circ\text{C}$  while providing a minimum of five air changes per hour.

6.10 *Micrometer*, having a resolution of at least 0.01 mm.

6.11 *Measuring Scale*, graduated in millimetres.

## 7. Test Specimens

7.1 The standard specimen geometry shall be  $13.0 \pm 0.5$  by  $125 \pm 5$  mm, and shall be provided in the minimum and maximum thickness. Materials thicker than 13 mm shall not be tested by this test method.

7.1.1 The test specimens shall be molded in accordance with the ASTM specifications for the material; or in accordance with the material manufacturer's instructions.

7.2 Surfaces shall be smooth and unbroken. Corner radius shall not exceed 1.3 mm. After any cutting operation, edges shall be fine-sanded to remove burrs, saw marks, and residual filaments.

## 8. Conditioning

8.1 Condition specimen sets as follows:

8.1.1 Condition one set of five specimens (Set A) for at least 48 h at a temperature of  $23 \pm 2^\circ\text{C}$  and a relative humidity of  $50 \pm 5\%$  prior to testing. Once removed from the conditioning room or chamber, specimens shall be tested within one hour. Condition one set of five specimens (Set A) in accordance with Procedure A of Practice D618 for a minimum of 48 hours. Once removed from the conditioning room or chamber, specimens shall be tested within one hour. Temperature and humidity tolerances shall be in accordance with Section 7 of Practice D618.

8.1.2 Condition a second set of five specimens (Set B) in a circulating-air oven for  $168 \pm 2$  h at  $70 \pm 2^\circ\text{C}$  and then cool in a desiccator for at least 4 h at room temperature prior to testing. Once removed from the desiccator, specimens shall be tested within 30 min.

8.2 All specimens shall be tested in a laboratory atmosphere of 15 to  $35^\circ\text{C}$  and 45 to 75 % relative humidity.

8.3 Cotton shall be conditioned in the desiccator for at least 24 hours prior to use. Once removed from the desiccator, the cotton shall be used within 30 minutes.

## 9. Procedure

9.1 Conduct the burning test in a chamber, enclosure, or laboratory hood free of induced or forced draft.

9.2 Clamp a specimen from the upper 6 mm of its length, with the longitudinal axis vertical, so that the lower end of the specimen is  $300 \pm 10$  mm above a horizontal layer of cotton, approximately 50 by 50 mm, thinned to a maximum uncompressed thickness of 6 mm, maximum mass of 0.08 g. See Fig. 1.

9.3 Place the burner remote from the specimen, ignite, and adjust it to produce a blue flame  $20 \pm 2$  mm high. Adjust the needle valve and the air ports of the burner until a 20-mm yellow-tipped blue flame is produced, and then increase the air supply until the yellow tip just disappears. Measure the height of the flame. If the flame height is not  $20 \pm 2$  mm, adjust the burner needle valve to give the proper flame height. The flame shall be confirmed using Practice D5207 at least once per month during active testing or whenever the gas supply is changed.

9.4 Approaching the specimen from the wide side in a horizontal plane (see Fig. 2), place the test flame centrally under the lower end of the test specimen with the burner tube  $10 \pm 1$  mm below the specimen and maintain that distance for a flame-impingement time of  $10.0 \pm 0.5$  s, moving the burner as necessary in response to any changes in the length or position of the specimen. Withdraw the test flame sufficiently so that there is no effect on the burning specimen (see Note 6) and measure the afterflame time, in seconds.

9.4.1 When the flaming of the specimen ceases, immediately place the test flame under the major portion of the specimen (see Note 7) maintaining a distance of  $10 \pm 1$  mm for a flame-impingement time of  $10.0 \pm 0.5$  s. After this second flame application, withdraw the test flame (see Note 6) and measure the afterflame and afterglow times, in seconds.

9.4.2 Record the afterflame time after the first flame application as  $t_1$ . Record the afterflame and afterglow times after the second flame application as  $t_2$  and  $t_3$ , respectively. Note and record whether any particles fall from the specimen and, if so, whether they ignite the cotton.

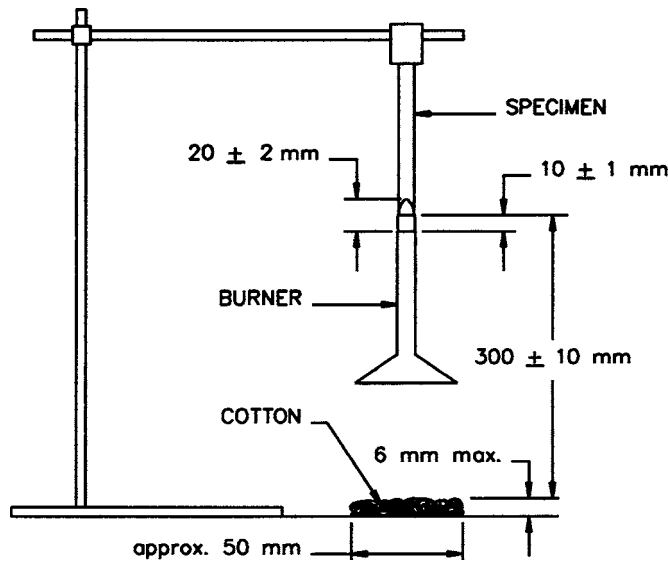

FIG. 1 Vertical Burning Test for V-0, V-1, and V-2 Classification

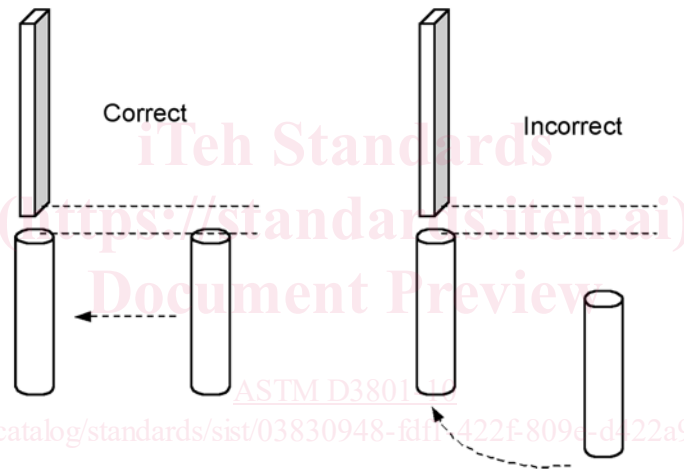

FIG. 2 Approaching the Specimen from the Wide Side in a Horizontal Plane

NOTE 6—Withdrawing the burner a distance of 150 mm from the specimen while measuring  $t_1$ ,  $t_2$ , and  $t_3$  has been found suitable.

NOTE 7—When the flaming of the specimen ceases after the first flame application, the second flame application shall be started immediately. The test shall not be interrupted, for example, to record data, replace cotton, or evacuate the test chamber.

NOTE 8—Measuring and recording the afterflame time  $t_2$  and then continuing the measurement of the sum of the afterflame time  $t_2$  and the afterglow time  $t_3$ , (without resetting the timing device) has been found satisfactory in the recording of  $t_3$ .

9.5 If the specimen drips molten or flaming material during either flame application, tilt the burner to an angle up to  $45^\circ$  towards the wide side of the specimen (see Fig. 3), and withdraw the burner slightly from one of the sides of the specimens during the flame application to avoid dripping into the tube of the burner. If the specimen drips molten or flaming material, or is consumed during the test, hand-hold the burner and maintain the proper distance between the bottom of the specimen and the top of the burner tube during the flame application. Disregard any molten strings of material for purposes of positioning the top of the burner tube. Always apply the flame to the bottom of the major portion of the specimen.

9.6 Repeat the procedure in 9.2-9.5 on the remaining specimens for each set.

## 10. Calculation

10.1 Calculate the total afterflame time for each set of five specimens,  $t_f$ , using the following formula:

$$t_f = \sum_{i=1}^5 (t_{1,i} + t_{2,i})$$

(1)