



Designation: ~~D5628-07~~ Designation: D5628 – 10

## Standard Test Method for Impact Resistance of Flat, Rigid Plastic Specimens by Means of a Falling Dart (Tup or Falling Mass)<sup>1</sup>

This standard is issued under the fixed designation D5628; the number immediately following the designation indicates the year of original adoption or, in the case of revision, the year of last revision. A number in parentheses indicates the year of last reapproval. A superscript epsilon ( $\epsilon$ ) indicates an editorial change since the last revision or reapproval.

### 1. Scope\*

1.1 This test method covers the determination of the threshold value of impact-failure energy required to crack or break flat, rigid plastic specimens under various specified conditions of impact of a free-falling dart (tup), based on testing many specimens.

1.2 The values stated in SI units are to be regarded as the standard. The values in parentheses are for information only.

1.3 *This standard does not purport to address all of the safety concerns, if any, associated with its use. It is the responsibility of the user of this standard to establish appropriate safety and health practices and determine the applicability of regulatory limitations prior to use.* Specific hazard statements are given in Section 8.

NOTE 1—This test method and ISO 6603-1 are technically equivalent only when the test conditions and specimen geometry required for Geometry FE and the Bruceton Staircase method of calculation are used.

### 2. Referenced Documents

#### 2.1 ASTM Standards:<sup>2</sup>

D618 Practice for Conditioning Plastics for Testing

D883 Terminology Relating to Plastics

D1600 Terminology for Abbreviated Terms Relating to Plastics

D1709 Test Methods for Impact Resistance of Plastic Film by the Free-Falling Dart Method

D2444 Test Method for Determination of the Impact Resistance of Thermoplastic Pipe and Fittings by Means of a Tup (Falling Weight)

D3763 Test Method for High Speed Puncture Properties of Plastics Using Load and Displacement Sensors

D4000 Classification System for Specifying Plastic Materials

D5947 Test Methods for Physical Dimensions of Solid Plastics Specimens

D6779 Classification System for Polyamide Molding and Extrusion Materials (PA)

E691 Practice for Conducting an Interlaboratory Study to Determine the Precision of a Test Method

#### 2.2 ISO Standards:<sup>3</sup>

ISO 291 Standard Atmospheres for Conditioning and Testing

ISO 6603-1 Plastics—Determination of Multiaxial Impact Behavior of Rigid Plastics—Part 1: Falling Dart Method

### 3. Terminology

#### 3.1 Definitions:

3.1.1 For definitions of plastic terms used in this test method, see Terminologies D883 and D1600.

#### 3.2 Definitions of Terms Specific to This Standard:

3.2.1 *failure (of test specimen)*—the presence of any crack or split, created by the impact of the falling tup, that can be seen by the naked eye under normal laboratory lighting conditions.

3.2.2 *mean-failure energy (mean-impact resistance)*—the energy required to produce 50 % failures, equal to the product of the constant drop height and the mean-failure mass, or, to the product of the constant mass and the mean-failure height.

3.2.3 *mean-failure height (impact-failure height)*—the height at which a standard mass, when dropped on test specimens, will cause 50 % failures.

NOTE 2—Cracks usually start at the surface opposite the one that is struck. Occasionally incipient cracking in glass-reinforced products, for example,

<sup>1</sup> This test method is under the jurisdiction of ASTM Committee D20 on Plastics and is the direct responsibility of Subcommittee D20.10 on Mechanical Properties. Current edition approved March 1, 2007-2010. Published March 2007-July 2010. Originally approved in 1994. Last previous edition approved in 2006-2007 as D5628 - 067. DOI: 10.1520/D5628-107.

<sup>2</sup> For referenced ASTM standards, visit the ASTM website, www.astm.org, or contact ASTM Customer Service at service@astm.org. For Annual Book of ASTM Standards volume information, refer to the standard's Document Summary page on the ASTM website.

<sup>3</sup> Available from American National Standards Institute (ANSI), 25 W. 43rd St., 4th Floor, New York, NY 10036, http://www.ansi.org.

\*A Summary of Changes section appears at the end of this standard.

is difficult to differentiate from the reinforcing fibers. In such cases, a penetrating dye can confirm the onset of crack formation.

3.2.4 *mean-failure mass (impact-failure mass)*—the mass of the dart (tup) that, when dropped on the test specimens from a standard height, will cause 50 % failures.

3.2.5 *tup*—a dart with a hemispherical nose. See 7.2 and Fig. 1.

#### 4. Summary of Test Method

4.1 A free-falling dart (tup) is allowed to strike a supported specimen directly. Either a dart having a fixed mass is dropped from various heights, or a dart having an adjustable mass is dropped from a fixed height. (See Fig. 2).

4.2 The procedure determines the energy (mass  $\times$  height) that will cause 50 % of the specimens tested to fail (mean failure energy).

4.3 The technique used to determine mean failure energy is commonly called the Bruceton Staircase Method or the Up-and-Down Method (1).<sup>4</sup> Testing is concentrated near the mean, reducing the number of specimens required to obtain a reasonably precise estimate of the impact resistance.

4.4 Each test method permits the use of different tup and test specimen geometries to obtain different modes of failure, permit easier sampling, or test limited amounts of material. There is no known means for correlating the results of tests made by different impact methods or procedures.

#### 5. Significance and Use

5.1 Plastics are viscoelastic and therefore are likely to be sensitive to changes in velocity of the mass falling on their surfaces. However, the velocity of a free-falling object is a function of the square root of the drop height. A change of a factor of two in the drop height will cause a change of only 1.4 in velocity. Hagan et al (2) found that the mean-failure energy of sheeting was constant at drop heights between 0.30 and 1.4 m. This suggests that a constant mass-variable height method will give the same results as the constant height-variable mass technique. On the other hand, different materials respond differently to changes in the velocity of impact. Equivalence of these methods should not be taken for granted. While both constant-mass and constant-height techniques are permitted by these methods, the constant-height method should be used for those materials that are found to be rate-sensitive in the range of velocities encountered in falling-weight types of impact tests.

5.2 The test geometry FA causes a moderate level of stress concentration and can be used for most plastics.

5.3 Geometry FB causes a greater stress concentration and results in failure of tough or thick specimens that do not fail with Geometry FA (3). This approach can produce a punch shear failure on thick sheet. If that type of failure is undesirable, Geometry FC should be used. Geometry FB is suitable for research and development because of the smaller test area required.

5.3.1 The conical configuration of the 12.7-mm diameter tup used in Geometry FB minimizes problems with tup penetration and sticking in failed specimens of some ductile materials.

5.4 The test conditions of Geometry FC are the same as those of Test Method A of Test Method D1709. They have been used in specifications for extruded sheeting. A limitation of this geometry is that considerable material is required.

5.5 The test conditions of Geometry FD are the same as for Test Method D3763.

5.6 The test conditions of Geometry FE are the same as for ISO 6603-1.

5.7 Because of the nature of impact testing, the selection of a test method and tup must be somewhat arbitrary. Although a choice of tup geometries is available, knowledge of the final or intended end-use application shall be considered.

5.8 Clamping of the test specimen will improve the precision of the data. Therefore, clamping is recommended. However, with rigid specimens, valid determinations can be made without clamping. Unclamped specimens tend to exhibit greater impact resistance.

5.9 Before proceeding with this test method, reference should be made to the specification of the material being tested. Table 1 of Classification System D4000 lists the ASTM materials standards that currently exist. Any test specimens preparation, conditioning, dimensions, or testing parameters or combination thereof covered in the relevant ASTM materials specification shall take precedence over those mentioned in this test method. If there are no relevant ASTM material specifications, then the default conditions apply.

#### 6. Interferences

6.1 Falling-mass-impact-test results are dependent on the geometry of both the falling mass and the support. Thus, impact tests should be used only to obtain relative rankings of materials. Impact values cannot be considered absolute unless the geometry of the test equipment and specimen conform to the end-use requirement. Data obtained by different procedures within this test method, or with different geometries, cannot, in general, be compared directly with each other. However, the relative ranking of materials is expected to be the same between two test methods if the mode of failure and the impact velocities are the same.

6.1.1 Falling-mass-impact types of tests are not suitable for predicting the relative ranking of materials at impact velocities differing greatly from those imposed by these test methods.

<sup>4</sup> The boldface numbers in parentheses refer to a list of references at the end of the text.

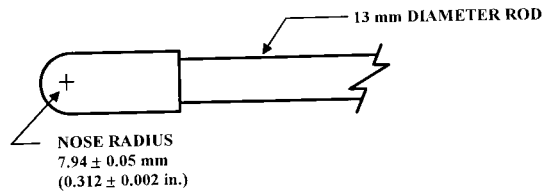

FIG. 1 (a)

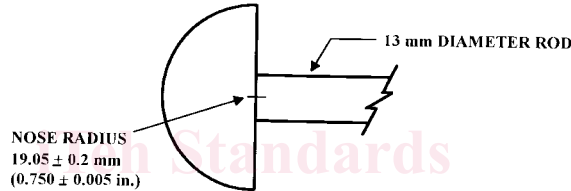
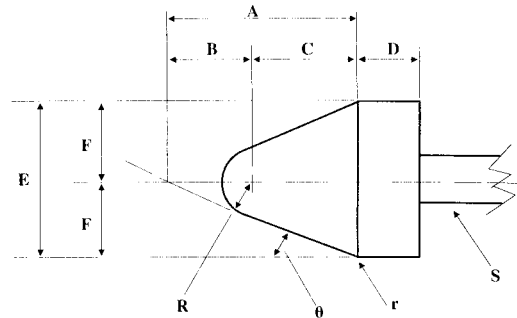

FIG. 1 (c)

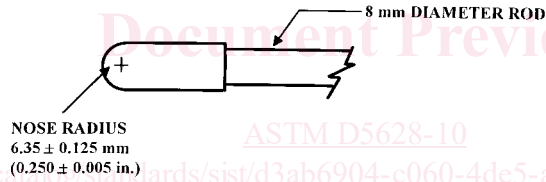

FIG. 1 (d)

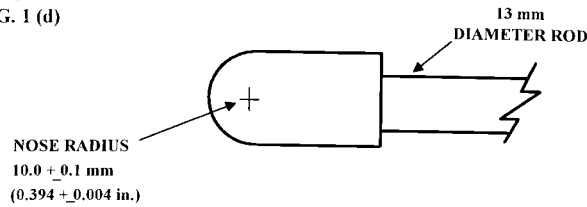

FIG. 1 (e)

Dimensions of Conical Dart (Not to scale.)—Fig. 1(b)

NOTE 1—Unless specified, the tolerance on all dimensions shall be ±2 %.

Position	Dimension, mm	Dimension, in.
A	27.2	1.07
B	15	0.59
C	12.2	0.48
D	6.4	0.25
E	25.4	1
F	12.7	0.5
R	6.35 ± 0.05	0.250 ± 0.002
(nose radius)		
r (radius)	0.8	0.03
S (diameter) <sup>A</sup>	6.4	0.25
θ	25 ± 1°	25 ± 1°

<sup>A</sup> Larger diameter shafts shall be used.

FIG. 1 Tup Geometries for Geometries FA (1a), FB (1b), FC (1c), FD (1d), and FE (1e)

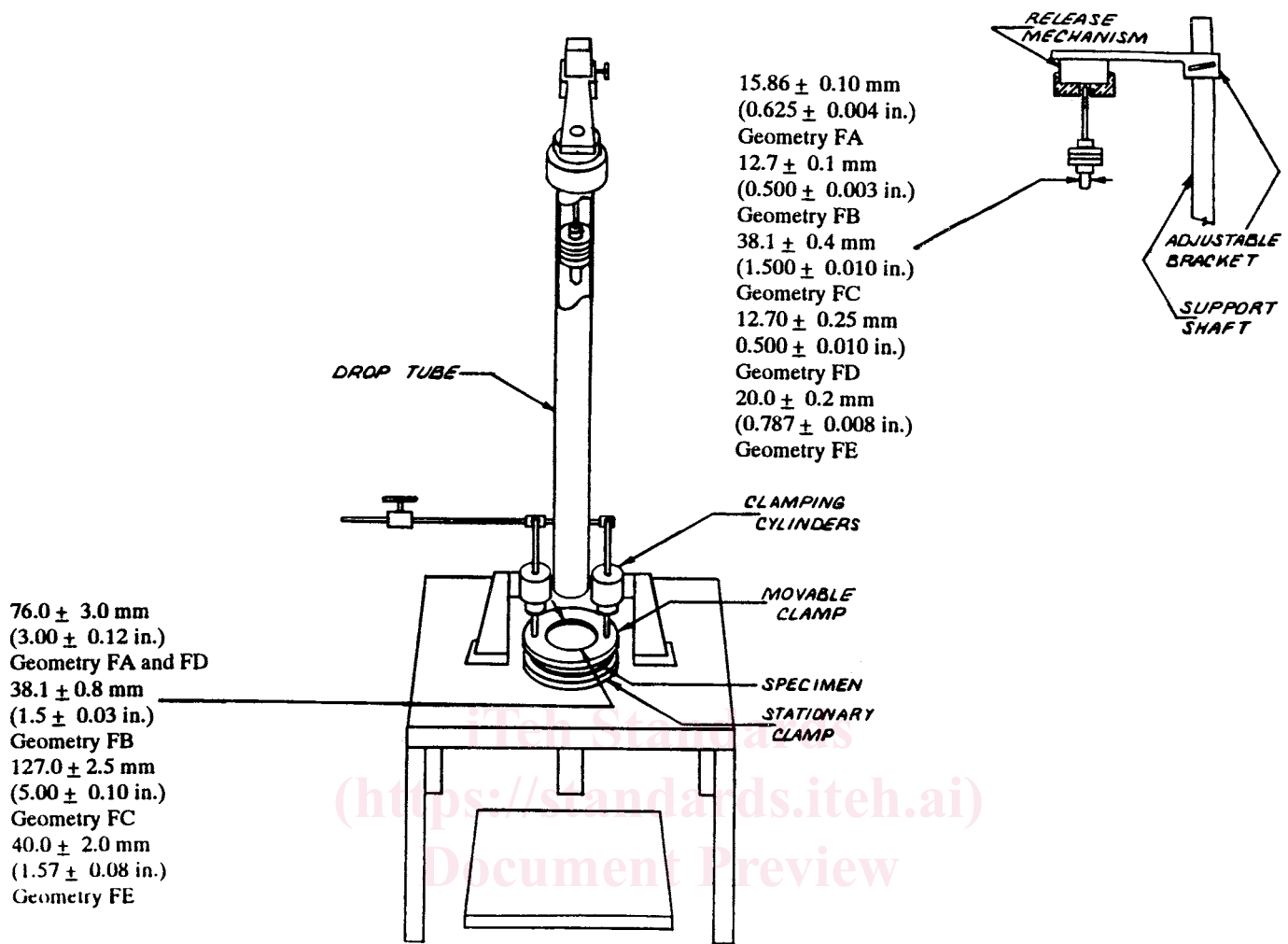

FIG. 2 One Type of Falling Mass Impact Tester

<https://standards.iteh.ai/catalog/standards/sist/d3ab6904-c060-4de5-a3e4-149962571de4/astm-d5628-10>

6.2 As cracks usually start at the surface opposite the one that is struck, the results can be greatly influenced by the quality of the surface of test specimens. Therefore, the composition of this surface layer, its smoothness or texture, levels of and type of texture, and the degree of orientation introduced during the formation of the specimen (such as during injection molding) are very important variables. Flaws in this surface will also affect results.

6.3 Impact properties of plastic materials can be very sensitive to temperature. This test can be carried out at any reasonable temperature and humidity, thus representing actual use environments. However, this test method is intended primarily for rating materials under specific impact conditions.

## 7. Apparatus

7.1 *Testing Machine*—The apparatus shall be constructed essentially as is shown in Fig. 2. The geometry of the specimen clamp and tup shall conform to the dimensions given in 7.1.1 and 7.2.

7.1.1 *Specimen Clamp*—For flat specimens, a two-piece annular specimen clamp similar to that shown in Fig. 3 is recommended. For Geometries FA and FD, the inside diameter should be 76.0 ± 3.0 mm [3.00(3.00 ± 0.12 in.)]. For Geometry FB, the inside diameter should be 38.1 ± 0.80 mm [1.5(1.5 ± 0.03 in.)]. For Geometry FC, the inside diameter should be 127.0 ± 2.5 mm [5.00(5.00 ± 0.10 in.)]. For Geometry FE an annular specimen clamp similar to that shown in Fig. 4 is required. The inside diameter should be 40 ± 2 mm [1.57(1.57 ± 0.08 in.)] (see Table 1). For Geometries FA, FB, FC, and FD, the inside edge of the upper or supporting surface of the lower clamp should be rounded slightly; a radius of 0.8 mm [0.03 in.](0.03 in.) has been found to be satisfactory. For Geometry FE this radius should be 1 mm [0.04 in.](0.04 in.).

7.1.1.1 Contoured specimens shall be firmly held in a jig so that the point of impact will be the same for each specimen.

7.1.2 *Tup Support*, capable of supporting a 13.5-kg [30-lb](30-lb) mass, with a release mechanism and a centering device to ensure uniform, reproducible drops.

NOTE 3—Reproducible drops are ensured through the use of a tube or cage within which the tup falls. In this event, care should be exercised so that any friction that develops will not reduce the velocity of the tup appreciably.

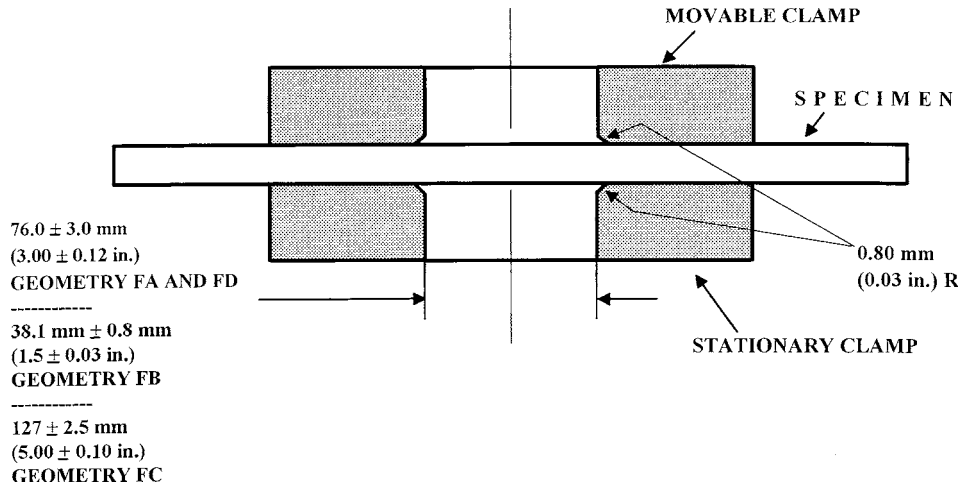

FIG. 3 Support Plate/Specimen/Clamp Configuration for Geometries FA, FB, FC, and FD

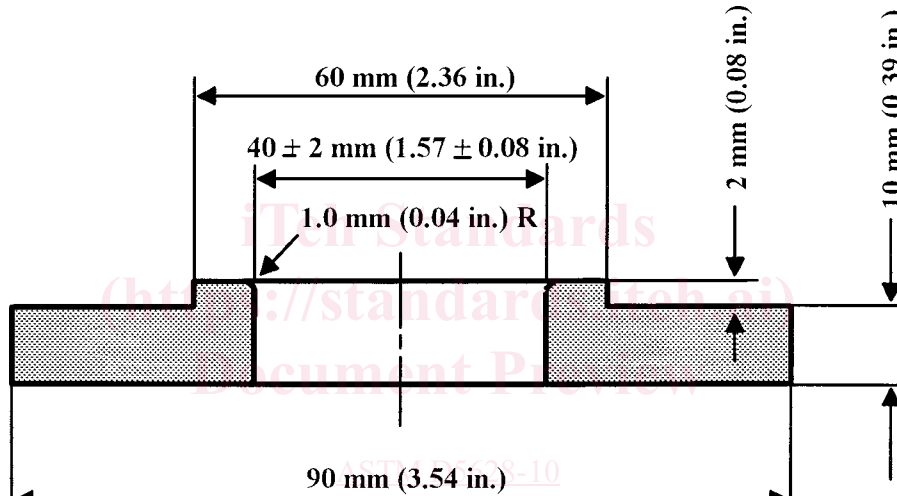

FIG. 4 Test-Specimen Support for Geometry FE

TABLE 1 Tip and Support Ring Dimensions

Geometry	Dimensions, mm-{(in.)}	
	Tip Diameter	Inside Diameter Support Ring
FA	15.86 ± 0.10 {0.625 ± 0.004} (0.625 ± 0.004)	76.0 ± 3.0 {3.00 ± 0.12} (3.00 ± 0.12)
FB	12.7 ± 0.1 {0.500 ± 0.003} (0.500 ± 0.003)	38.1 ± 0.8 {1.5 ± 0.03} (1.5 ± 0.03)
FC	38.1 ± 0.4 {1.5 ± 0.010} (1.5 ± 0.010)	127.0 ± 2.5 {5.00 ± 0.10} (5.00 ± 0.10)
FD	12.70 ± 0.25 {0.500 ± 0.010} (0.500 ± 0.010)	76.0 ± 3.0 {3.00 ± 0.12} (3.00 ± 0.12)
FE	20.0 ± 0.2 {0.787 ± 0.008} (0.787 ± 0.008)	40.0 ± 2.0 {1.57 ± 0.08} (1.57 ± 0.08)

7.1.3 *Positioning Device*—Means shall be provided for positioning the tip so that the distance from the impinging surface of the tip head to the test specimen is as specified.

7.2 *Tip*:

7.2.1 The tip used in Geometry FA shall have a 15.86 ± 0.10-mm {0.625(0.625 ± 0.004-in.)} diameter hemispherical head of tool steel hardened to 54 HRC or harder. A steel shaft about 13 mm {0.5-in.}(0.5 in.) in diameter shall be attached to the center

of the flat surface of the head with its longitudinal axis at 90° to that surface. The length of the shaft shall be great enough to accommodate the maximum mass required (see Fig. 1(a) and Table 1).

7.2.2 The tup used in Geometry FB shall be made of tool steel hardened to 54 HRC or harder. The head shall have a diameter of  $12.7 \pm 0.1$  mm  $\{0.500(0.500 \pm 0.003 \text{ in.})\}$  with a conical (50° included angle) configuration such that the conical surface is tangent to the hemispherical nose. A 6.4-mm  $\{0.25\text{-in.}\}$  diameter shaft is satisfactory (see Fig. 1(b) and Table 1).

7.2.3 The tup used for Geometry FC shall be made of tool steel hardened to 54 HRC or harder. The hemispherical head shall have a diameter of  $38.1 \pm 0.4$  mm  $\{1.5(1.5 \pm 0.015 \text{ in.})\}$ . A steel shaft about 13 mm  $\{0.5\text{-in.}\}$  in diameter shall be attached to the center of the flat surface of the head with its longitudinal axis at 90° to that surface. The length of the shaft shall be great enough to accommodate the maximum mass (see Fig. 1(c) and Table 1).

7.2.4 The tup used in Geometry FD shall have a  $12.70 \pm 0.25$ -mm  $\{0.500(0.500 \pm 0.010\text{-in.})\}$  diameter hemispherical head of tool steel hardened to 54 HRC or harder. A steel shaft about 8 mm  $\{0.31\text{-in.}\}$  in diameter shall be attached to the center of the flat surface of the head with its longitudinal axis at 90° to the surface. The length of the shaft shall be great enough to accommodate the maximum mass required (see Fig. 1(d) and Table 1).

7.2.5 The tup used in Geometry FE shall have a  $20.0 \pm 0.2$ -mm  $\{0.787(0.787 \pm 0.008\text{-in.})\}$  diameter hemispherical head of tool steel hardened to 54 HRC or harder. A steel shaft about 13 mm  $\{0.5\text{-in.}\}$  in diameter shall be attached to the center of the flat surface of the head with its longitudinal axis at 90° to the surface. The length of the shaft shall be great enough to accommodate the maximum mass required (see Fig. 1(e) and Table 1).

7.2.6 The tup head shall be free of nicks, scratches, or other surface irregularities.

7.3 *Masses*—Cylindrical steel masses are required that have a center hole into which the tup shaft will fit. A variety of masses are needed if different materials or thicknesses are to be tested. The optimal increments in tup mass range from 10 g or less for materials of low impact resistance, to 1 kg or higher for materials of high impact resistance.

7.4 *Micrometer*, for measurement of specimen thickness. It should be accurate to within 1 % of the average thickness of the specimens being tested. See Test Methods D5947 for descriptions of suitable micrometers.

7.5 The mass of the tup head and shaft assembly and the additional mass required must be known to within an accuracy of  $\pm 1$  %.

## 8. Hazards

### 8.1 Safety Precautions:

8.1.1 Cushioning and shielding devices shall be provided to protect personnel and to avoid damage to the impinging surface of the tup. A tube or cage can contain the tup if it rebounds after striking a specimen.

8.1.2 When heavy weights are used, it is hazardous for an operator to attempt to catch a rebounding tup. Figure 2 of Test Method D2444 shows an effective mechanical “rebound catcher” employed in conjunction with a drop tube.

## 9. Sampling

9.1 Sample the material to meet the requirements of Section 14.

## 10. Test Specimens

10.1 Flat test specimens shall be large enough so that they can be clamped firmly if clamping is desirable. See Table 2 for the

**TABLE 2 Minimum Size of Specimen**

Geometry	Specimen Diameter, mm [in.]	Square Specimen, mm [in.]
FA	89 [3.5]	89 by 89
FA	89 (3.5)	89 by 89 [3.5 by 3.5] (3.5 by 3.5)
FB	51 [2.0]	51 by 51
FB	51 (2.0)	51 by 51 [2.0 by 2.0] (2.0 by 2.0)
FC	140 [5.5]	140 by 140
FC	140 (5.5)	140 by 140 [5.5 by 5.5] (5.5 by 5.5)
FD	89 [3.5]	89 by 89
FD	89 (3.5)	89 by 89 [3.5 by 3.5] (3.5 by 3.5)
FE	58 [2.3]	58 by 58
FE	58 (2.3)	58 by 58 [2.3 by 2.3] (2.3 by 2.3)