



Designation: D6068-96 (Reapproved 2002)^{ε1} Designation: D6068 - 10

Standard Test Method for Determining *J-R* Curves of Plastic Materials¹

This standard is issued under the fixed designation D6068; the number immediately following the designation indicates the year of original adoption or, in the case of revision, the year of last revision. A number in parentheses indicates the year of last reapproval. A superscript epsilon (ϵ) indicates an editorial change since the last revision or reapproval.

~~^{ε1}Note—Editorially corrected figure reference in paragraph 7.3 in November 2002.~~

1. Scope

1.1 This test method covers the determination of the *J*-integral versus crack growth resistance (*J-R*) curves for polymeric materials.

1.2 This test method is intended to characterize the slow, stable crack growth resistance of bend-type specimens in such a manner that it is geometry insensitive within limits set forth in this test method.

1.3 The recommended specimens are the three-point bend (*SE (B)*) and pin-loaded compact tension (*C (T)*) specimens. Both specimens have in-plane dimensions of constant proportionality for all sizes. Specimen configurations other than those recommended in this test method may require different procedures and validity requirements.

1.4 This test method describes a multiple specimen method that requires optical measurement of crack extension from fracture surfaces. It is not recommended for use with materials in which the crack front cannot be distinguished from additional deformation processes in advance of the crack tip.

1.5 The values stated in SI units are to be regarded as the standard.

1.6 *This standard does not purport to address all of the safety concerns, if any, associated with its use. It is the responsibility of the user of this standard to establish appropriate safety and health practices and determine the applicability of regulatory limitations prior to use.*

NOTE 1—There is no equivalent ISO standard.

2. Referenced Documents

2.1 *ASTM Standards*:²

D618 Practice for Conditioning Plastics for Testing

D4066 Classification System for Nylon Injection and Extrusion Materials (PA)

D5045 Test Methods for Plane-Strain Fracture Toughness and Strain Energy Release Rate of Plastic Materials

E399 Test Method for Linear-Elastic Plane-Strain Fracture Toughness K_{Ic} of Metallic Materials

E616 Terminology Relating to Fracture Testing (Discontinued 1996)

E1152 Test Method for Determining *J-R* Curves

E1737 Test Method for *J*-Integral Characterization of Fracture Toughness (Discontinued 1998)

F1473 Test Method for Notch Tensile Test to Measure the Resistance to Slow Crack Growth of Polyethylene Pipes and Resins

3. Terminology

3.1 *Definitions*—Terminology related to fracture testing contained in Terminology E616 is applicable to this test method.

3.2 *Definitions of Terms Specific to This Standard*:

3.2.1 *J*-integral, $J (FL^{-1})$ —a mathematical expression, a line or surface integral over a path that encloses the crack front from one crack surface to the other, used to characterize the local stress-strain field around the crack front. See Terminology E616 for additional discussion.

3.2.2 *J-R curve*—a plot of resistance to stable physical crack extension, Δa_p .

3.2.3 *net thickness*, $B_N (L)$ —the distance between the roots of the side grooves in side grooved specimens.

3.2.4 *original crack size*, $a_0 (L)$ —the physical crack size at the start of testing.

¹ This test method is under the jurisdiction of ASTM Committee D20 on Plastics and is the direct responsibility of Subcommittee D20.10 on Mechanical Properties. Current edition approved November 10, 2002. Published January 2003. Originally approved in 1996. Last previous edition approved in 1996 as D6068-96. DOI: 10.1520/D6068-96R02E01.

Current edition approved July 1, 2010. Published July 2010. Originally approved in 1996. Last previous edition approved in 2002 as D6068-96(2002)^{ε1}. DOI: 10.1520/D6068-10.

² For referenced ASTM standards, visit the ASTM website, www.astm.org, or contact ASTM Customer Service at service@astm.org. For *Annual Book of ASTM Standards* volume information, refer to the standard's Document Summary page on the ASTM website.

3.2.5 *original uncracked ligament, $b_0 (L)$* —the distance from the original crack front to the back edge of the specimen ($b_0 = W - a_0$).

3.2.6 *physical crack extension, $\Delta a_p (L)$* —an increase in physical crack size ($\Delta a_p = a_p - a_0$).

3.2.7 *physical crack size, $a_p (L)$* —the distance from a reference line to the observed crack front. The distance may be a calculated average of several measurements along the crack front. The reference line depends on the specimen geometry and is normally defined as in 3.2.10. The reference line is defined prior to specimen deformation.

3.2.8 *specimen span, $S(L)$* —the distance between specimen supports for the *SE (B)* specimen.

3.2.9 *specimen thickness, $B(L)$* —the side-to-side dimension of the test specimen (shown in Fig. 2).

3.2.10 *specimen width, $W(L)$* —a physical dimension on a test specimen measured from the rear surface of the specimen to a reference line (for example, the front edge of a bend specimen or the load line of a compact specimen).

4. Summary of Test Method

4.1 This test method describes a multiple specimen technique for determining the *J-R* curve for polymeric materials. The *J-R* curve consists of a plot of *J* versus crack extension in the region of *J*-controlled growth as determined by the data qualification requirement of 9.2.

4.2 This test method uses optical measurements of crack length and crack extension on the fracture surfaces after each test.

5. Significance and Use

5.1 A *J-R* curve produced in accordance with this test method characterizes the crack growth resistances of a wide range of tough polymers and polymer blends (**1-5**)³ that cannot be obtained in sufficient size and thickness for valid characterization by linear elastic fracture mechanics in Test Methods D5045.

5.2 The *J-R* curve characterizes, within the limits set forth in this test method, the resistance of a polymeric material to slow stable crack growth after initiation from a preexisting sharp flaw.

5.3 A *J-R* curve can be used as an index of material toughness for blend or alloy design, material selection, materials processing, and quality assurance (**6**).

5.4 The *J-R* curves from bend specimens represent lower bound estimates of *J* capacity as a function of crack extension, and have been observed to be conservative relative to those obtained from specimen configurations under tensile loading.

5.5 The *J-R* curves for a given material of constant microstructure tend to exhibit lower slope (flatter) with increasing thickness. Thus, it is recommended that the largest possible specimen with representative microstructure be used.

5.6 The *J-R* curve can be used to assess the stability of cracks in structures in the presence of ductile tearing, with awareness of the differences that may exist between laboratory test and field conditions.

³ The boldface numbers given in parentheses refer to a list of references at the end of the text.

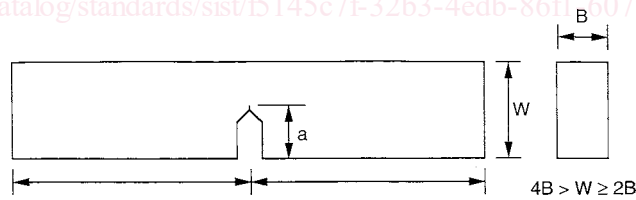

(a) Three-Point Bend Specimen SE(B).

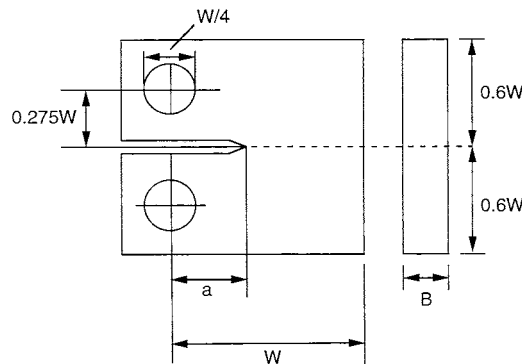

(b) Compact Tension Configuration C(T).

FIG. 1 Specimen Configurations

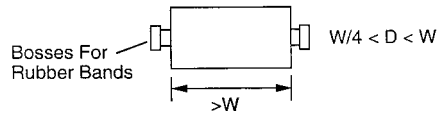
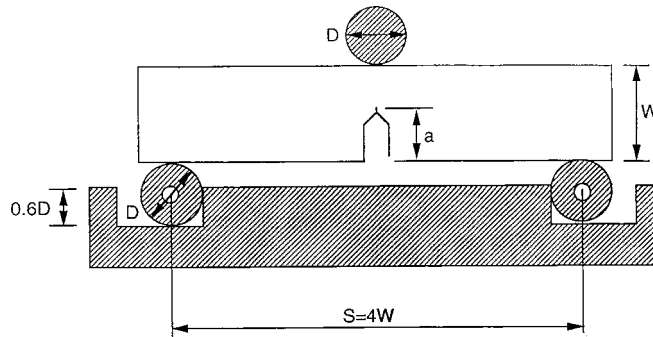

FIG. 2 Bending Rig

5.7 A J - R curve may depend on the orientation and propagation of the crack in relation to the anisotropy of the material which may be induced by specimen fabrication methods.

5.8 Because of the possibility of rate dependence of crack growth resistance, J - R curves can be determined at displacement rates other than that specified in this test method (7).

6. Apparatus

6.1 Measurements of applied load and load-line displacement are needed to obtain the total energy absorbed by the specimen. Load versus load-line displacement may be recorded digitally or autographically.

6.2 *Testing Machine*—The J -integral tests are to be conducted under displacement control to maximize the attainable amount of stable crack extension in the test specimens.

NOTE 2—The extent to which the crack grows in a stable manner is dependent on the machine stiffness (8) and the mode of control of loading (9).

6.3 *Bend Test Fixture*—A suggested fixture for $SE(B)$ specimens is shown in Fig. 2. The fixture may have either stationary or moving rollers of sufficiently large diameter to minimize excessive plastic indentation.

6.4 *Grips for C(T) Specimens*—A suggested clevis and pin arrangement for gripping compact specimens is given in Test Method E399. This arrangement accommodates specimens with $B = 0.5 W$.

6.5 Displacement Measurement:

6.5.1 Load-line displacement measurements are needed to calculate J from the area under the load-displacement record.

6.5.2 The remote displacement measurement can be performed using the stroke or position transducer on the testing machine. Data obtained in this manner must be corrected for extraneous displacements (such as indentation effects, pin penetration, or machine compliance) by conducting a separate indentation measurement described in 8.7.

6.5.3 A direct displacement measurement can be performed using a separate displacement transducer. This arrangement is shown in Fig. 2 for $SE(B)$ specimens. For $C(T)$ specimens, the displacement gage should be placed in the notch on the load line.

7. Specimen Configuration, Size, and Preparation

7.1 Specimen Size:

7.1.1 The initial selection of specimen size and dimensions can only be based on J results estimated from previous experience. Generally, the largest available specimens are recommended for testing in order to obtain a larger portion of the J - R curve and to obtain the most conservative estimate of crack growth resistance.

7.1.2 Any thickness may be used with the understanding that the J - R curve will be limited by the maximum crack extension considerations of 9.2 and that the J - R curve is only appropriate for the thickness that is being evaluated.

7.2 Specimen Configurations:

7.2.1 The recommended $SE(B)$ and $C(T)$ specimens are similar to the configurations in Test Methods D5045 and are shown in Fig. 1. The specimens can be modified to permit load-line displacement measurement. Suggested modifications are given in Test Method E1152.

7.2.2 All in-plane dimensions are proportional to the specimen width, W . The thickness is nominally $B = 0.5 W$.

7.2.3 The original crack length, a_0 , shall be greater than $0.5 W$, but less than $0.65 W$.

7.2.4 The span, S , to width, W , ratio in $SE(B)$ specimens shall be 4.

7.2.5 *Side Grooves*—Specimens may need side grooves to promote straighter crack fronts during testing. The side grooves should be equal in depth and have an included angle of $45 \pm 5^\circ$ with a root radius of $0.25 \text{ m} \pm 0.05 \text{ mm}$. The total thickness reduction may not exceed $0.20 B$. Side grooves must be used when the crack front requirements of 9.2.3 cannot be met with plane sided specimens.

7.2.6 Alternative specimens may have $2 \leq W/B \leq 4$.

7.3 *Indentation Correction Specimens*—Separately prepared unnotched test specimens are used for indentation displacement and energy corrections. The specimens are shown in Fig. 3.

7.4 *Conditioning*:

7.4.1 Condition the test specimens at $23 \pm 2^\circ\text{C}$ and $50 \pm 5\% \text{ to } 10\%$ relative humidity for not less than 40 h prior to test in accordance with Procedure A of Practice D618, for those tests where conditioning is required. In cases of disagreement, the tolerances shall be $\pm 1^\circ\text{C}$ and $\pm 2\% \text{ to } \pm 5\%$ relative humidity.

7.4.2 Note that for some hygroscopic materials, such as nylons, the material specifications (for example, Specification D4066) call for testing “dry as molded specimens.” Such requirements take precedence over the above routine preconditioning to 50 % relative humidity and require sealing the specimens in water vapor-impermeable containers as soon as molded and not removing them until ready for testing.

7.5 *Notching*:

7.5.1 The objective of the notching procedure is to obtain the sharpest possible crack with minimal damage to the material in advance of the crack tip.

7.5.2 Machine a pre-notch into the specimen to a depth of $0.5 W$ using either a saw or a single-point flycutter.

7.5.3 Create a natural crack by inserting a razor blade into the pre-notch and tapping it into the specimen and forcing the crack to grow in advance of the razor blade tip.

7.5.4 If a natural crack cannot be successfully generated by tapping the razor blade, slide a fresh, unused razor blade across the root of the machined pre-notch.

7.5.5 The length of the razor crack shall not be less than 5 % of the total original crack length, a_0 .

7.5.6 *Alternative Notching Techniques*:

7.5.6.1 Fatigue pre-notching is permissible. Suggested notching conditions are given in Test Method E1152. Because of the possibility of hysteretic heating leading to subsequent damage, frequencies less than 4 Hz are recommended.

7.5.6.2 Pressing a fresh razor blade into the notch is also permissible provided that damage to the material is minimized. Suggested notching conditions and equipment are given in Test Method F1473.

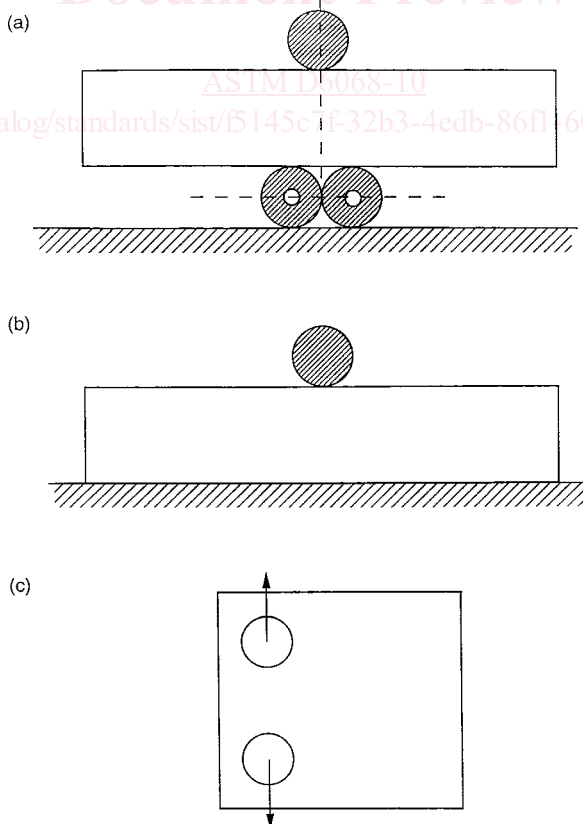

FIG. 3 Arrangements for Finding Indentation Displacement

8. Procedure

8.1 *Testing Procedure*—The objective of this procedure is to develop a J - R curve consisting of J -integral values at spaced crack extensions, Δa_p , as described in 9.3.2. In the multi-specimen method, each test specimen is to develop a single point on the J - R curve. A series of specimens are loaded to different displacements using crosshead or displacement control. The resulting crack fronts are marked (as described in Appendix X1) and the crack extensions are measured from the fracture surface. An independent indentation measurement is also conducted to correct for non-fracture related energy dissipation. The J value is then calculated from the indentation corrected energy for fracture. Each specimen has thus provided a set of J , Δa_p values to describe the J - R curve.

8.2 Measure specimen dimensions B , B_N , and W to the nearest 0.050 mm or 0.5 % accuracy, whichever is larger.

8.3 Because of the viscoelastic nature of polymers, the J - R curve may be dependent on test temperature and displacement rate. Therefore, record these conditions with the results.

8.3.1 Provided that stable, well-defined crack growth can be achieved, any test temperature may be used.

8.3.2 Similarly, any test speed that leads to stable, well-defined crack growth may be used. However, test speeds that lead to loading times (time to maximum load) that are less than 1 ms are not recommended for this procedure due to dynamic effects on the loading signal that can lead to erroneous results.

8.3.3 For general characterization, the suggested test conditions in the standard laboratory atmosphere are $23 \pm 2^\circ\text{C}$ and $50 \pm 5\%$ relative humidity. The suggested test speed is 1 mm/min.

8.4 *Number of Specimens*—A minimum of seven specimens are used to generate the power law fit to the data. All shall be machined to the same dimensions. The initial precrack lengths should be as consistent as possible. The objective is to replicate the initial portion of the load versus load-line displacement traces as much as possible.

8.5 Take each specimen through the following steps:

8.5.1 Load to a selected displacement level that is judged to produce a crack extension in a desired position on the J - R curve in accordance with 9.3.2. Use displacement or clip gage control in order to control the amount of crack growth and minimize crack growth instability. Record the load versus load-line displacement curve.

8.5.2 Unload the specimen, mark the crack front (see Appendix X1), and break the specimen to expose the fracture surface.

8.6 *Crack Length and Crack Extension Measurement*—The original crack length, a_0 , and the individual crack extensions, Δa_p , are measured from the fracture surface to the nearest 0.010 mm or 0.5 % accuracy, whichever is larger.

8.6.1 The original crack length (machined notch plus crack) is calculated from the average of three measurements at distances of $B/4$, $B/2$, and $3B/4$ (or, for grooved specimens, $B_N/4$, $B_N/2$, and $3B_N/4$) from a side of the specimen along the original crack front on the fracture surface (Fig. 4).

8.6.2 Along the front of the region of stable crack extension, measure the crack length at five equally spaced points centered about the specimen centerline and extending to $0.005W$ from the surfaces of plane sided specimens or from the roots of the side grooves in grooved specimens (Fig. 5). Calculate the average physical crack size, a_p , as follows: average the two near-surface measurements, combine the result with the remaining three measurements, and determine the average of these four values.

8.6.3 Calculate the average physical crack extension, $\Delta a_p (= a_p - a_0)$.

8.7 *Indentation Correction:* [catalog/standards/sist/15145c71-32b3-4edb-86f1-60790ea8a89b/astm-d6068-10](https://www.astm.org/catalog/standards/sist/15145c71-32b3-4edb-86f1-60790ea8a89b/astm-d6068-10)

8.7.1 Use an unnotched calibration specimen (shown in Fig. 3) that is of the same geometry as the individual specimens used in the J tests.

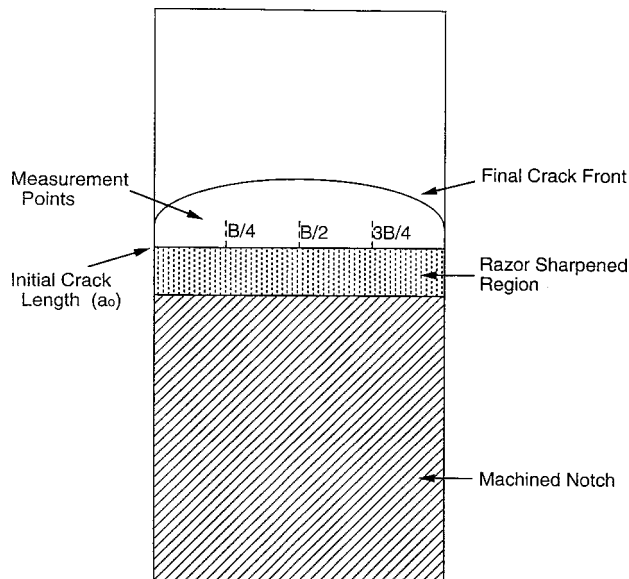

FIG. 4 Measurement of Initial Crack Length (a_0)

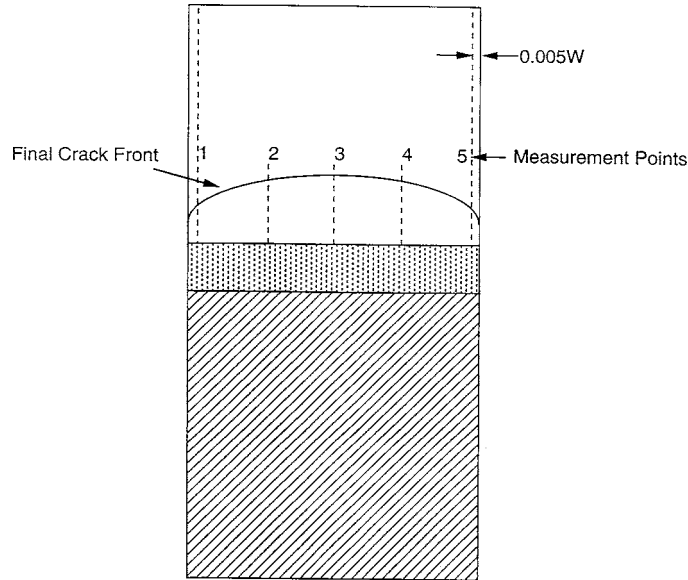

FIG. 5 Measurement of Crack Growth (Δa)

8.7.2 For the unnotched bend specimens, the fixtures shall be positioned to minimize the amount of specimen bending by either positioning the bottom supports of the bend fixture as closely together as possible (see Fig. 3(a)) or supporting the specimen on a flat plate (see Fig. 3(b)). The indenter shall be the same geometry as that used in the J tests. For the unnotched $C(T)$ specimens, clevis grips of the same geometry as those used in the J tests shall be used (see Fig. 3(c)).

8.7.3 Load the specimen to a maximum load that is at least 10 % greater than the maximum load used in the set of individual J tests while recording the load versus load-point displacement curve. The loading rate and test temperature shall be identical for the indentation correction and J tests.

9. Calculation and Interpretation of Results

9.1 J Calculation:

9.1.1 The energy required to extend the crack, U , is used to calculate J . The total energy, U_T , determined from the area under the load versus load-point displacement curve obtained for each specimen (see Fig. 6) is the sum of U and U_i , the indentation energy.

9.1.2 For $C(T)$ specimens, the indentation energy, U_i , for each J test specimen is obtained by integrating the load versus load-point displacement curve measured in the indentation test up to the displacement that corresponds to the maximum load for that J test specimen.

9.1.2.1 For $SE(B)$ specimens, the indentation energy, U_i , is dependent on the fixturing of the indentation test. If the indentation specimen is supported on two supports that are positioned closely together (that is, a span that is still large enough to allow separate indentations), U_i is obtained as in 9.1.2. For indentation $SE(B)$ specimens that are supported on a flat, rigid surface, U_i should

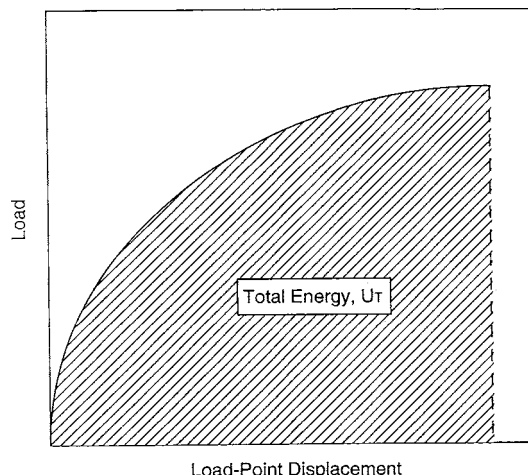

FIG. 6 Definition of Total Energy (U_T)