



Designation: D6497 – 02(Reapproved 2010)

Standard Guide for Mechanical Attachment of Geomembrane to Penetrations or Structures¹

This standard is issued under the fixed designation D6497; the number immediately following the designation indicates the year of original adoption or, in the case of revision, the year of last revision. A number in parentheses indicates the year of last reapproval. A superscript epsilon (ϵ) indicates an editorial change since the last revision or reapproval.

1. Scope

1.1 This guide covers procedures that can be employed to mechanically attach fabricated geomembranes to structures, pipes, etc.

1.2 This guide does not address all problems or situations a geomembrane installer or design engineer may face in the attachment of geomembranes to structures, pipes, etc. The sole purpose of this standard guide is to point out typical problems with geomembrane attachments and clearly state objectives of each component of the geomembrane attachment(s).

1.3 This guide has been generated for geomembrane application(s); however, a geomembrane installer or design engineer, or both, may find portions of this guide applicable to other geosynthetics.

1.4 The values stated in SI units are to be regarded as standard. No other units of measurement are included in this standard.

1.5 *This standard does not purport to address all of the safety concerns, if any, associated with its use. It is the responsibility of the user of this standard to establish appropriate safety and health practices and determine the applicability of regulatory limitations prior to use.*

2. Referenced Documents

2.1 EPA Document:

Quality Assurance and Quality Control for Waste Containment Facilities, Technical Guidance Document, United States Environmental Protection Agency, EPA/600/R-93/182, September 1993²

3. Terminology

3.1 Definitions:

3.1.1 *banding strap, n*—a flexible narrow strip of metal, plastic or other material, which compresses the geomembrane around a penetration by acting as a clamp around the penetration.

3.1.2 *batten, n*—a rigid narrow strip of metal, wood, plastic or other material which distributes the forces to compress the geomembrane against a penetration or structure.

3.1.3 *boot, n*—a factory or field fabricated geomembrane wrap used to seal around a pipe penetration prior to attachment (see Fig. 1).

3.1.4 *clamp, n*—a flexible narrow strip of metal, plastic or other material, which compresses the geomembrane against a penetration by tightening the bolt(s) or screw(s) of the clamp (see Fig. 2).

3.1.5 *concrete, n*—a homogeneous mixture of portland cement, aggregates, and water which may contain admixtures. (C822)

3.1.6 *gaskets, n*—a material, which may be clamped between contact surfaces that acts as a static seal. Gaskets are cut, formed, or molded into the desired configuration. They may consist of any of the following construction: one or more plies of a sheet material; composites of dissimilar materials; and materials applied as a bead or other form to one or both mating faces prior to assembly. (F118)

3.1.7 *geomembrane, n*—an essentially impermeable geosynthetic composed of one or more synthetic sheets. (D4439)

3.1.8 *rondel, n*—a strip of polymeric material formed to a geometry, which is embedded and secured to a penetration or structure (for example, concrete structure) (see Fig. 3).

3.1.9 *sealant*—in building construction, a material that has the adhesive and cohesive properties to form a seal. (C717)

3.1.10 *torque, n*—a movement (of forces) which produces or tends to produce rotation or torsion. (D4848)

3.1.11 *void space, n*—in engineered structures, space(s) between the geomembrane and penetration or structure, which allow liquid or vapor migration, or allow the geomembrane to deform into the space(s) due to overburden pressure. (New, to be balloted under Terminology Committee.)

¹ This guide is under the jurisdiction of ASTM Committee D35 on Geosynthetics and is the direct responsibility of Subcommittee D35.10 on Geomembranes.

Current edition approved July 1, 2010. Published July 2010. Originally published in 1999 as D6497-99. Last previous edition approved in 2002 as D6497-02. DOI: 10.1520/D6497-02R10.

² Available from Superintendent of Documents, US Government Printing Office, Washington, DC 20402.

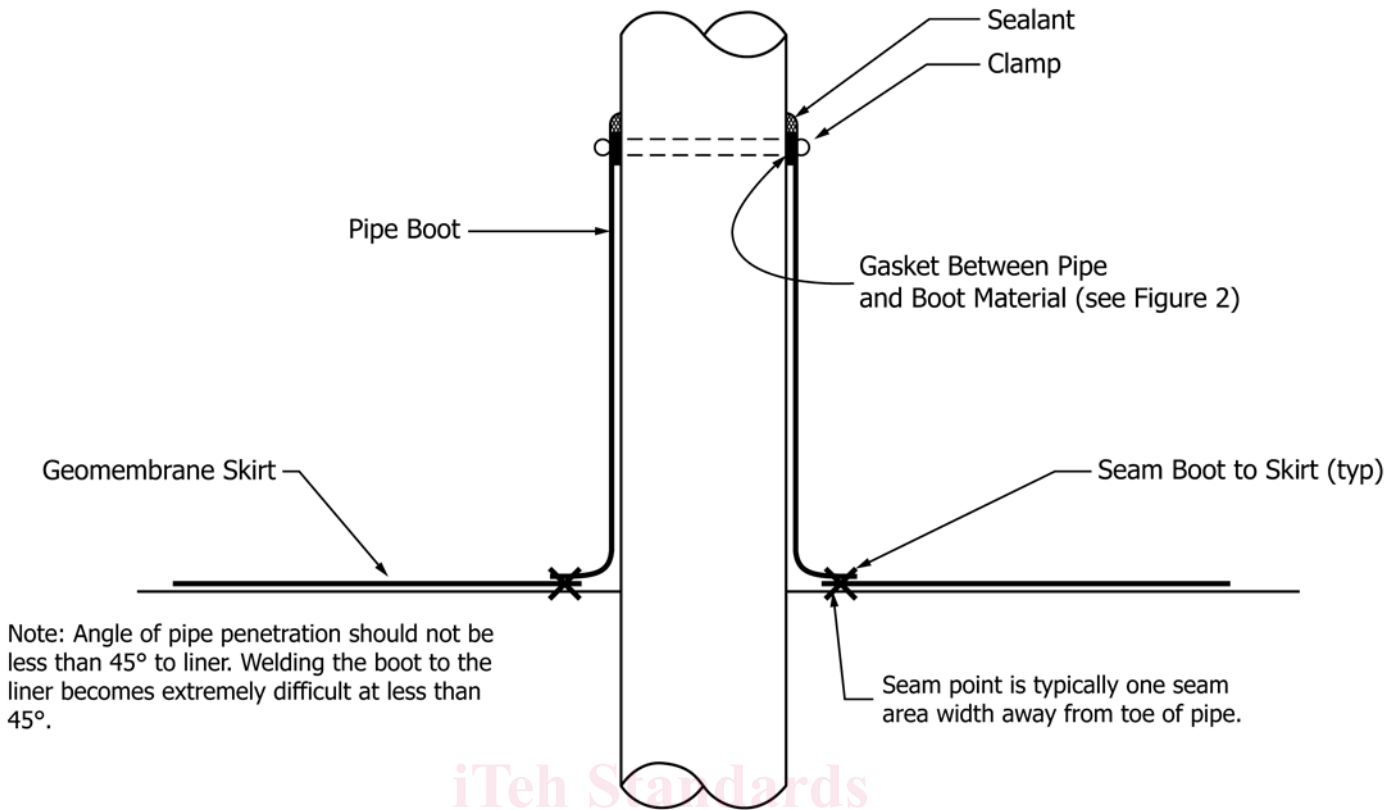

FIG. 1 Pipe Penetration—Perpendicular Face

4. Significance and Use

4.1 This guide attempts to detail specific areas of concern regarding the attachment of geomembranes to structures. Components of the geomembrane attachment are addressed as to the type and use of each component.

4.2 Although this guide does not address all aspects of geomembrane attachments, the user of this guide may note important objectives and design issues of each component of the geomembrane. All these objectives and design issues may or may not be required to obtain an appropriate geomembrane attachment. By describing these areas of concern, it is hoped that the user of this guide will be able to design geomembrane attachments, develop specifications or construct geomembrane attachments, or both, which fulfill the requirements of its design intent.

5. Types of Connection

5.1 *Batten(s)*—Battens are commonly used to attach a geomembrane to a smooth, flat surface. Anchor bolts are embedded into the penetration or structure at set locations. A gasket is placed in-line with the bolts to form a seal between the geomembrane and structure. Geomembrane is pushed or forced over the bolts to insure a tight fit and then placed against the penetration or structure. The batten, which has holes in it that are in alignment with the bolts, is placed over the geomembrane. Nuts are placed on the bolts and tightened with

sufficient torque to compress the geomembrane against the penetration or structure. The geomembrane is held in place by the friction generated by the compression effect of the batten (see Fig. 4).

5.1.1 A compression sealant or gasket can be used between the geomembrane and the penetration or structure or batten, or both. The compression sealant or gasket will limit the migration of liquid or vapor through the batten connection.

5.2 *Clamp(s) or Banding Strap(s)*—Clamps or banding straps are commonly used to attach a geomembrane to a smooth, round penetration or structure (for example, pipe). The geomembrane is placed around the penetration or structure and welded as close as possible to the circumference of the penetration or structure. A gasket is placed around the penetration or structure at the location of the clamp placement to form a seal between the geomembrane and penetration or structure. The geomembrane is then put in-place and over the gasket. The clamp or banding strap is commonly tightened by applying a torque to a bolt or bolts, a screw or screws, or other mechanical device, which applies a pulling force that decreases the length of the clamp, or banding strap, thereby compressing the geomembrane and gasket to the penetration or structure. The geomembrane is held in place by the friction generated by tightening the clamp or banding strap and compressing the geomembrane against the penetration or structure.

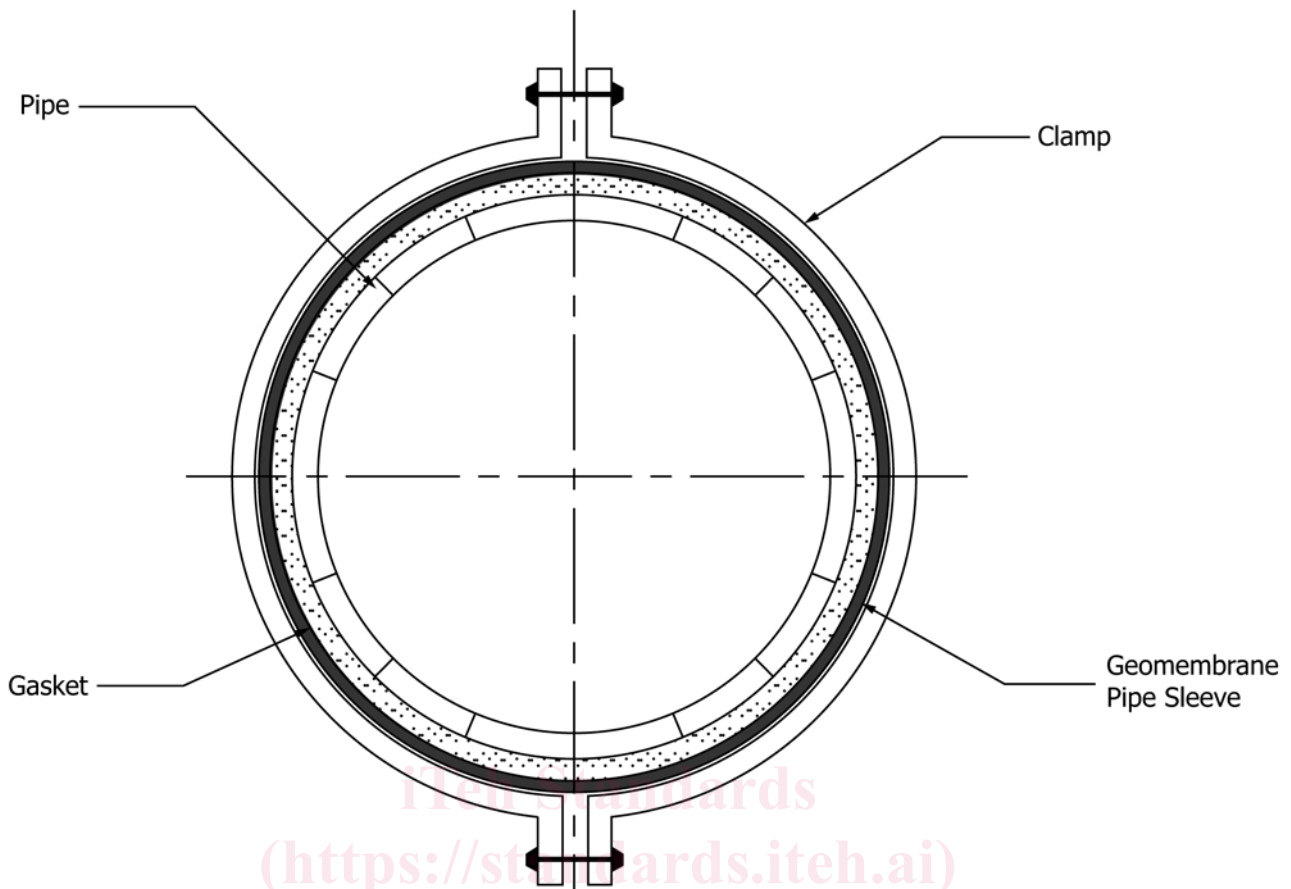

FIG. 2 Clamp Detail

5.2.1 A compression sealant or gasket can be used between the geomembrane and the penetration or structure or clamp, or both. The compression sealant or gasket will limit the migration of liquid or vapor through the clamp connection.

5.3 *Welded*—Welded connections can be either a solvent weld or heat weld. Heat welding of dissimilar materials can be accomplished as long as both materials are thermoplastic. It is recommended that welding criteria for dissimilar materials be reviewed with the material manufacturer before constructing the attachment.

5.3.1 The welded connections are commonly made to a rondel or pipe (see Fig. 5) composed of similar polymeric material as the geomembrane. The rondel is embedded into the penetration or structure during its construction. For example, rondels are commonly embedded into a concrete structure. The material used for the penetration or structure is allowed to cure before attachment of the geomembrane. The curing time allows the rondel to become secured in the penetration or structure. Once the material used for the penetration or structure has cured sufficiently to reduce the risk of pulling the rondel from the penetration or structure, the geomembrane can be welded to the rondel (see Fig. 3).

5.3.2 Welding geomembranes to rondels and pipes is similar to welding geomembrane panels together. The geomembrane must be placed flush against the rondel or pipe during the

welding process. The geomembrane and rondel or pipe must be clean or prepared, or both, according to the prescribed geomembrane manufacturer's procedure before welding.

5.3.3 Welding the geomembrane to the penetration or structure may provide an attachment that has a lower possibility of leakage. Since the geomembrane is attached directly to the structure, sealants are usually not required. However, special attention should be noted for rondels used for attachment of geomembranes to concrete structures. If several sections or pieces of rondels are required to construct an attachment, spaces or gaps between the individual sections or pieces could occur during their embedment and during the curing of the concrete. This would especially occur for rondels made of polymeric material that expands and contracts according to the temperature of the concrete during the curing process. Sealants may be required to fill the spaces or gaps between the rondels to further limit the migration of liquid or vapor through the batten connection.

5.3.4 Pre-fabrication of the complete rondel attachment before placement into the concrete is recommended. The pre-fabricated rondel is composed of welded sections or pieces of rondels, thereby eliminating the possibility of gaps between sections or pieces on rondels after the concrete cures.

5.4 *Bonded*—Bonded connections commonly require the use of an adhesive to construct the attachment. The use of an

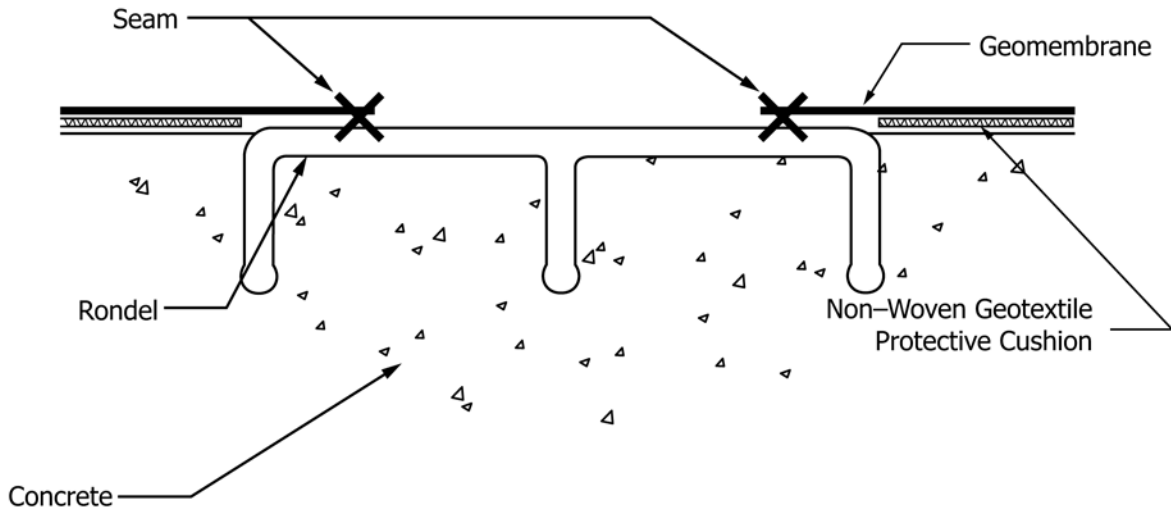

NOTE: RONDELS ARE MANUFACTURED IN VARIOUS SHAPES BY DIFFERENT MANUFACTURERS. CONTACT MANUFACTURER REGARDING DESIGN.

FIG. 3 Rondel Connection

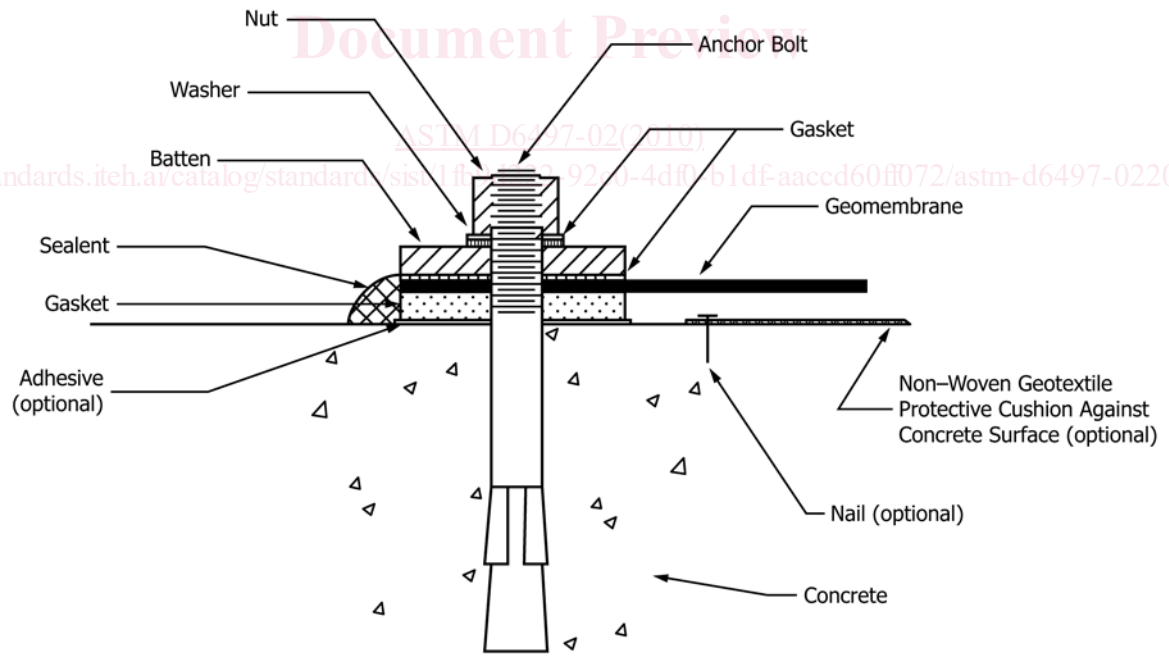
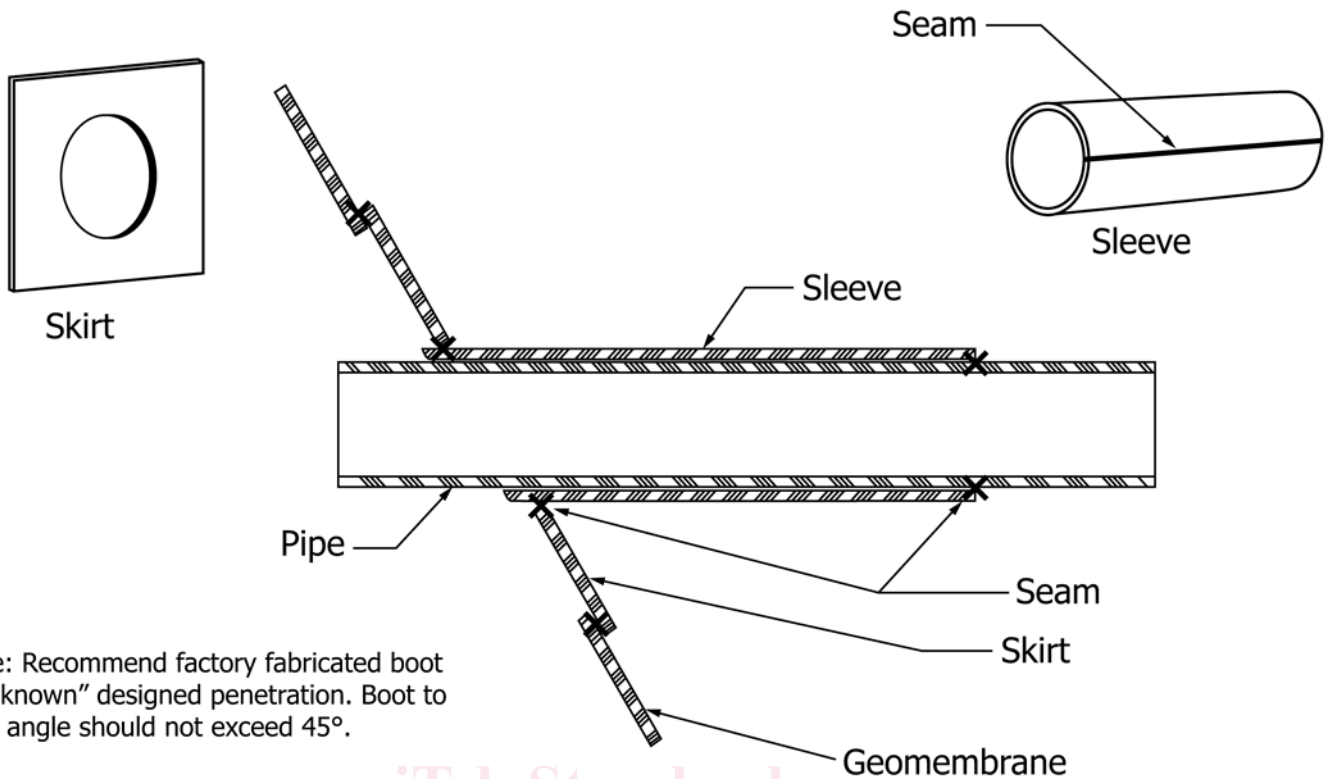

FIG. 4 Anchor Bolt Geomembrane Connection

adhesive allows the geomembrane to be attached to dis-similar material. The adhesive used must be compatible with both the geomembrane and the surface material of the penetration or

structure. The application and curing of the adhesive should not significantly deteriorate the strength of the geomembrane



Note: Recommend factory fabricated boot for "known" designed penetration. Boot to pipe angle should not exceed 45°.

FIG. 5 Pipe Boot

or the material surface of the penetration or structure beyond the design requirements of the attachment.

5.4.1 The geomembrane and the surface of the penetration or structure should be clean and prepared according to the adhesive manufacturer's and geomembrane manufacturer's recommendation.

5.4.2 Bonding the geomembrane to the penetration or structure may provide an attachment, which has a lower possibility of leakage. Since the geomembrane is attached directly to the structure, sealants are usually not required.

6. Types of Structures

6.1 *Concrete*—Concrete structures that require attachment of geomembranes include, but are not limited to, pads, floors, walls, tanks, manholes, and pylons. The use of battens, clamps or banding strips, or bonding can attach a geomembrane to concrete structures. When attaching a geomembrane to any concrete structure, consider each critical concern detailed in Section 7.

6.2 *Metal*—Metal structures that require attachment of geomembranes include, but are not limited to, pads, floors, walls, pipes, and tanks. The use of battens, clamps or banding strips, can attach a geomembrane to metal structures. When attaching a geomembrane to any metal structure, consider each critical concern detailed in Section 7.

6.3 *Pipe*—Pipe structures can be composed of concrete, metal or polymer. Clamps, banding strips, solvent weld, or heat weld can attach a geomembrane to pipe structures. The attachment of a geomembrane to any pipe structure should consider critical concerns detailed in 7.1, 7.3, 7.4, 7.5, and 7.6.

7. Critical Areas for the Protection of the Geomembrane

7.1 *Surface Characteristics*—The surface of the structure for which the geomembrane is to be attached should be constructed or formed to limit damage to the geomembrane. This is particularly important in cases where the geomembrane will be pressed against the structure. Irregularities in the structure surface could cause stress points in the geomembrane, thereby, allowing portion(s) of the geomembrane to yield at a lower load than its design application. If a structure cannot be constructed or formed without irregularities, then a protective layer should be placed between the structure and the geomembrane (see Fig. 4).

7.2 *Edges of Structures*—Edges or corners of structures should be rounded to limit possible damage to the geomembrane. A protective layer can be constructed or placed over the edge or corner to protect the geomembrane.

7.3 *Large Voids Under Geomembrane*—Large voids under the geomembrane can cause deformation and stress in the geomembrane and geomembrane seams if, under pressure or load, the geomembrane is forced into the void(s). Large voids should be filled or bridged to stop the geomembrane and geomembrane seams from becoming overly stressed (see Figs. 6 and 7).

7.4 *Settlement Around Structures*—If a geomembrane is to be connected to a structure and placed over an area which may settle at a greater or lesser rate than the structure, the design engineer or geomembrane installer should take precautions to limit settlement around the structure. If settlement around the structure cannot be avoided, then the design engineer should

Cover batten strips with 4 layers of 8-ounce geotextile to protect liner (typical).

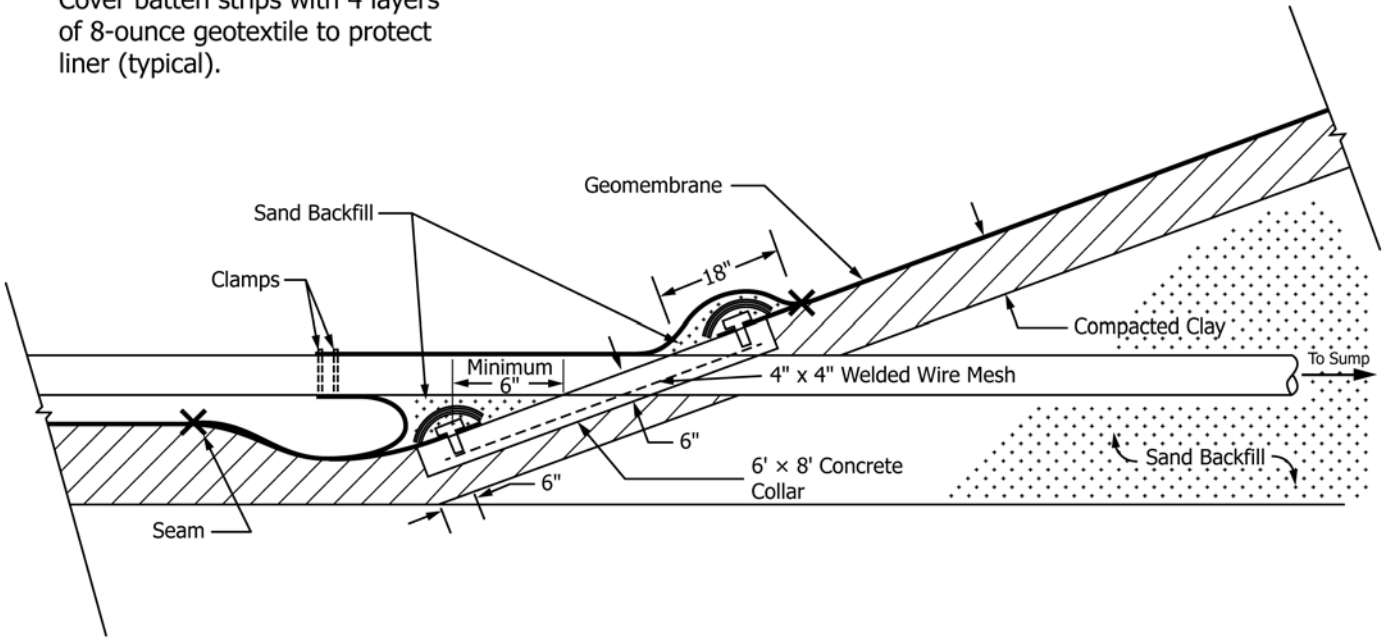

FIG. 6 Liner Penetration Detail

Note: There are many different types of tank corner details. However, any corner design should support the geomembrane and alleviate possible geomembrane stresses during tank use.

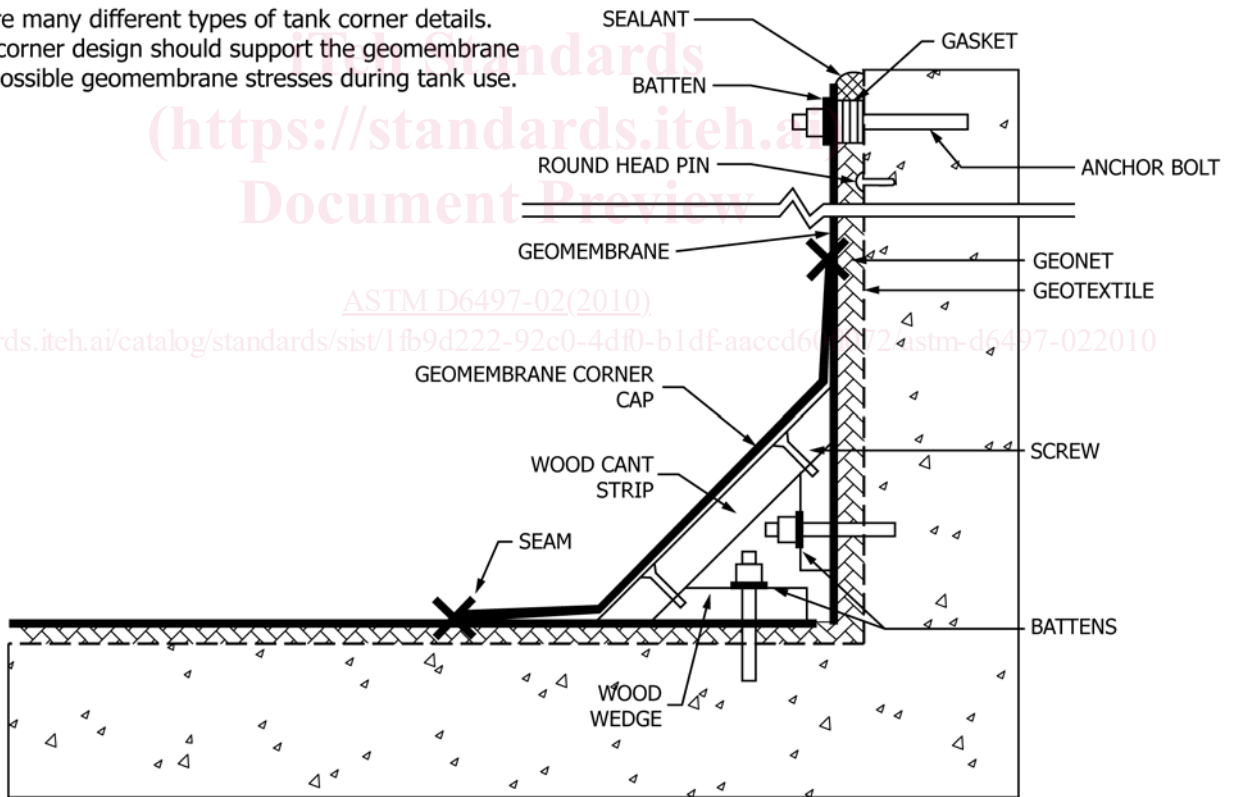

FIG. 7 Tank Corner Detail

design a flexible connection to the structure that considers settlement and alleviates the stresses, which could occur due to settlement.

7.5 In-Plane Attachment—The geomembrane should be placed in parallel or “in-plane” with the structure or penetration to be attached. The geomembrane should lie flat against the