



Designation: D7594 – 10

Standard Test Method for Determining Fretting Wear Resistance of Lubricating Greases Under High Hertzian Contact Pressures Using a High-Frequency, Linear-Oscillation (SRV) Test Machine¹

This standard is issued under the fixed designation D7594; the number immediately following the designation indicates the year of original adoption or, in the case of revision, the year of last revision. A number in parentheses indicates the year of last reapproval. A superscript epsilon (ϵ) indicates an editorial change since the last revision or reapproval.

1. Scope

1.1 This test method covers a procedure for determining the lubricating action of greases in order to prevent “fretting” wear under linear oscillation with associated low strokes and high Hertzian contact pressures under high-frequency linear-oscillation motion using the SRV test machine. By performing additional, nonmandatory extreme-pressure tests in accordance with Test Method D5706, the test grease should be shown to be able to withstand a Hertzian contact pressure of at least 2200 MPa without adhesive failure.

1.2 The values stated in SI units are to be regarded as standard. No other units of measurement are included in this standard.

1.3 *This standard does not purport to address all of the safety concerns, if any, associated with its use. It is the responsibility of the user of this standard to establish appropriate safety and health practices and determine the applicability of regulatory limitations prior to use.*

2. Referenced Documents

2.1 *ASTM Standards:*²

A295/A295M Specification for High-Carbon Anti-Friction Bearing Steel

D217 Test Methods for Cone Penetration of Lubricating Grease

D4175 Terminology Relating to Petroleum, Petroleum Products, and Lubricants

D5706 Test Method for Determining Extreme Pressure Properties of Lubricating Greases Using a High-Frequency, Linear-Oscillation (SRV) Test Machine

D6425 Test Method for Measuring Friction and Wear Prop-

erties of Extreme Pressure (EP) Lubricating Oils Using SRV Test Machine

D7421 Test Method for Determining Extreme Pressure Properties of Lubricating Oils Using High-Frequency, Linear-Oscillation (SRV) Test Machine

E45 Test Methods for Determining the Inclusion Content of Steel

G40 Terminology Relating to Wear and Erosion

2.2 *DIN Standards:*³

DIN 51834-3:2008-12 Testing of lubricants – Tribological test in translatory oscillation apparatus – Part 3: Determination of tribological behaviour of materials in cooperation with lubricants

DIN 51631:1999 Special-boiling-point spirits - Requirements and testing

DIN EN ISO 683-17 Heat-treated steels, alloy steels and free-cutting steels - Part 17: Ball and roller bearing steels (replaces DIN 17230-1980)

DIN EN ISO 13565-2:1998 Geometrical Product Specifications (GPS) - Surface texture: Profile method - Surfaces having stratified functional properties - Part 2: Height characterization using the linear material ratio curve (replaces DIN 4776-1990)

2.3 *ISO Standards*⁴

ISO 1250:1972 Mineral solvents for paints -- White spirits and related hydrocarbon solvents

3. Terminology

3.1 *Definitions:*

3.1.1 *break-in, n—in tribology*, an initial transition process occurring in newly established wearing contacts, often accompanied by transients in coefficient of friction or wear rate, or both, that are uncharacteristic of the given tribological system’s long-term behavior. **G40**

¹ This test method is under the jurisdiction of ASTM Committee D02 on Petroleum Products and Lubricants and is the direct responsibility of Subcommittee D02.G0.04 on Functional Tests - Tribology.

Current edition approved May 1, 2010. Published August 2010. DOI:10.1520/D7594-10.

² For referenced ASTM standards, visit the ASTM website, www.astm.org, or contact ASTM Customer Service at service@astm.org. For *Annual Book of ASTM Standards* volume information, refer to the standard’s Document Summary page on the ASTM website.

³ Available from Available from Beuth Verlag GmbH (DIN-- DIN Deutsches Institut für Normung e.V.), Burggrafenstrasse 6, 10787, Berlin, Germany, http://www.en.din.de.

⁴ Available from International Organization for Standardization (ISO), 1, ch. de la Voie-Creuse, Case postale 56, CH-1211, Geneva 20, Switzerland, http://www.iso.ch.

3.1.2 *coefficient of friction, μ or f , n* —in tribology, the dimensionless ratio of the friction force (F) between two bodies to the normal force (N) pressing these bodies together. **G40**

3.1.3 *Hertzian contact area, n* —apparent area of contact between two nonconforming solid bodies pressed against each other, as calculated from Hertz' equations of elastic deformation. **G40**

3.1.4 *Hertzian contact pressure, n* —magnitude of the pressure at any specified location in a Hertzian contact area, as calculated from Hertz' equations of elastic deformation. **G40**

3.1.5 *lubricant, n* —any material interposed between two surfaces that reduces the friction or wear between them. **D4175**

3.1.6 *lubricating grease, n* —a semi-fluid to solid product of a dispersion of a thickener in a liquid lubricant. **D217**

3.1.6.1 *Discussion*—The dispersion of the thickener forms a two-phase system and immobilizes the liquid lubricant by surface tension and other physical forces. Other ingredients are commonly included to impart special properties.

3.1.7 *Ra (C.L.A.), n* —in measuring surface finish, the arithmetic average of the absolute distances of all profile points from the mean line for a given distance.

3.1.7.1 *Discussion*—C.L.A. means center line average, and it is a synonym to Ra. **Amstutz, p. 21⁵**

3.1.8 *Rpk, n* —Reduced peak height according to **DIN EN ISO 13565-2:1998**. *Rpk* is the mean height of the peak sticking out above the core profile section.

3.1.9 *Rvk, n* —Reduced valley height according to **DIN EN ISO 13565-2:1998**. *Rvk* is the mean depth of the valley reaching into the material below the core profile section.

3.1.10 *Ry, n* —in measuring surface finish, the vertical distance between the top of the highest peak and the bottom of the deepest valley in one sampling length. **Amstutz, p. 25⁵**

3.1.11 *Rz (DIN), n* —in measuring surface finish, the average of all *Ry* values (peak to valley heights) in the assessment length. **Amstutz, pp. 29, 31⁵**

3.1.12 *thickener, n* —in lubricating grease, a substance composed of finely divided particles dispersed in a liquid lubricant to form the product's structure. **D217**

3.1.12.1 *Discussion*—The thickener can be fibers (such as various metallic soaps) or plates or spheres (such as certain non-soap thickeners) which are insoluble or, at most, only very slightly soluble in the liquid lubricant. The general requirements are that the solid particles be extremely small, uniformly dispersed, and capable of forming a relatively stable, gel-like structure with the liquid lubricant.

3.2 *Definitions of Terms Specific to This Standard:*

3.2.1 *extreme pressure, adj*—in lubrication, characterized by metal surface in contact under high-stress rubbing conditions.

3.2.2 *fretting wear, n* —wear arising as a result of fretting. Small amplitude oscillatory motion, usually tangential, between two solid surfaces in contact.

3.2.3 *seizure, n* —localized adhesion of polymer onto metal between the rubbing surfaces of the test pieces.

3.2.3.1 *Discussion*—In this test method, seizure is indicated by a sharp rise in the coefficient of friction, over steady state, of greater than 0.2 for over 20 s, or a coefficient of friction >0.35 or by any examples shown in Test Method **D5706** and **D7421**). If any of these conditions occur, the test is not valid. (These criteria were believed to be right, because this standard is related to greases.) The evidence of adhesive wear morphologies should be controlled by micro-optical examination of the wear scar and track. In severe cases, a stoppage in the motor will occur.

3.2.4 *SRV, n* —Schwingung, Reibung, Verschleiß (German); oscillating, friction, wear (English translation).

4. Summary of Test Method

4.1 This test method is performed on an SRV test machine using a steel test ball oscillating under constant frequency, short stroke amplitude and under constant load (F_n), against a stationary steel test disk with a grease lubricant between them in order to determine the coefficient of friction and wear scar diameter.

4.2 For the non-mandatory extreme pressure test (see **Appendix X1**), the test load is increased in 100-N increments until seizure occurs (see Test Method **D5706**). The load, immediately prior to the load at which seizure occurs, is measured and reported.

NOTE 1—Test frequency, stroke length, temperature, and ball and disk material can be varied to simulate field conditions. The test ball yields point-contact geometry. To obtain line or area contact, test pieces of differing configurations can be substituted for the test balls.

4.3 The friction force, F_f , is measured by a piezo-electric device in the test disk assembly. Peak values of coefficient of friction, f , are determined and recorded as a function of time for SRV I and II models. SRV III and IV models can display the hysteresis (Friction force or coefficient of friction over stroke length) and save test data electronically.

4.4 After a preset test period, the test machine and chart recorder stopped and the wear scar on the ball is measured. If a profilometer is available, a trace of the wear track on the test disk and the wear scar of the ball (See **DIN 51834-3** and **Appendix X1**) can also be used to obtain additional wear information. Wear volume in mm^3 and wear rate of disk and ball in mm^3/Nm .

5. Significance and Use

5.1 This test method can be used to determine anti-wear properties and coefficient of friction of greases in order to prevent “fretting” wear under linear oscillation with associated low strokes and high Hertzian contact pressures at selected temperatures and loads specified for use in applications in which induced, high-speed vibrational motions are present for extended periods of time. It has found application as a screening test for grease lubricants used in ball and roller bearings, roller or ball screw (spindle) drives or side shaft systems (Tripode or Rzeppa type) for example, so-called constant velocity (CV) joints. Users of this test method should determine whether results correlate with field performance or other applications.

⁵ Amstutz, Hu, “Surface Texture: The Parameters,” Bulletin MI-TP-003-0785, Sheffield Measurement Division, Warner and Swasey, 1985.



NOTE—Above: Model III; Below: Model IV
FIG. 1 SRV Test Machine

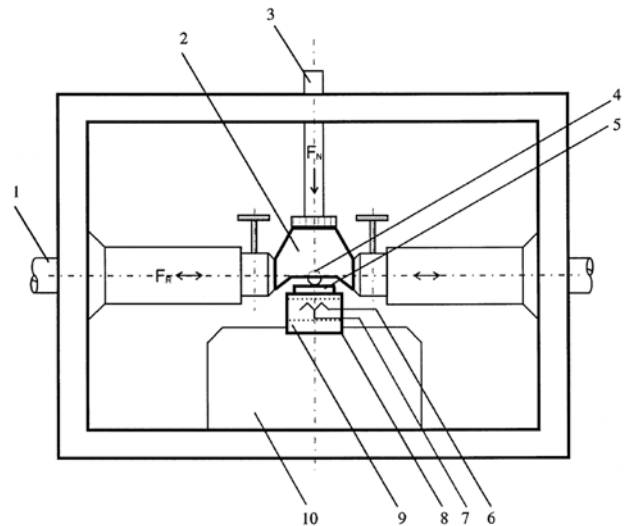

- | | |
|--------------------------|-----------------------------------|
| 1. Oscillation drive rod | 6. Electrical Resistance Heater |
| 2. Test Ball Holder | 7. Resistance Thermometer |
| 3. Load Rod | 8. Test Disk Holder |
| 4. Test Ball | 9. Piezoelectric Measuring Device |
| 5. Test Disk | 10. Receiving Block |

FIG. 2 Test Chamber Elements

7.2 *Lower Test Disk*⁶—Vacuum arc remelted (VAR) AISI 52100 steel with an inclusion rating using Method D, Type A, as severity level number of 0.5 in accordance with Test Methods E45 and Specification A295/A295M or an inclusion sum value $K1 \leq 10$ in accordance with DIN EN ISO 683-17 and spheroidized annealed to obtain globular carbide, 60 ± 2 Rc hardness, the surfaces of the disk being lapped and free of lapping raw materials. The topography of the disk will be determined by four values, 24-mm diameter by 7.85 mm thick:

- 0.5 $\mu\text{m} < Rz < 0.650 \mu\text{m}$
- 0.035 $\mu\text{m} < \text{C.L.A. (Ra)} < 0.050 \mu\text{m}$
- 0.020 $\mu\text{m} < Rpk < 0.035 \mu\text{m}$
- 0.050 $\mu\text{m} < Rvk < 0.075 \mu\text{m}$

7.3 *Cleaning Solvent*—The test disks have to be cleaned by a liquid solvent (non-chlorinated, non-film forming). It is recommended to use special boiling point spirit type 2-A in accordance with DIN 51631:1999 or ISO 1250:1972. (Warning—Flammable. Health hazard.)

8. Preparation of Apparatus

8.1 Turn on the test machine and chart recorder and allow to warm up for 15 min prior to running tests.

8.2 Select the friction data to be presented in the crest peak value position in accordance with the manufacturer's directions.

NOTE 2—In most cases, this is accomplished by positioning the sliding switch on electronic card NO. 291.35.20E (front side of electronics behind the front panel) and the sliding switch located back on the panel of the control unit.

8.3 Turn the amplitude knob to ZERO.

8.4 Switch the stroke adjustment to AUTO position.

8.5 Set the frequency to 50 Hz and duration to 4 h, 00 min, 30 s in accordance with the manufacturer's instructions.

6. Apparatus

6.1 *SRV Test Machine*⁶—Illustrated in Fig. 1 and Fig. 2.

7. Reagents and Materials

7.1 *Test Balls*⁶—52100 steel, 60 ± 2 Rc hardness, $0.025 \pm 0.005\text{-}\mu\text{m}$ Ra surface finish, 10-mm diameter.

⁶ The sole source of supply of the apparatus known to the committee at this time is Optimol Instruments GmbH, Westendstr. 125, D-80339 Munich, Germany. If you are aware of alternative suppliers, please provide this information to ASTM International Headquarters. Your comments will receive careful consideration at a meeting of the responsible technical committee,¹ which you may attend.

8.6 Set the load charge amplifier to the setting that corresponds to the load foreseen for the test in accordance with the manufacturer's instructions. Select the desired chart speed.

NOTE 3—In later SRV models, the load charge amplifier is set automatically.

9. Procedure

9.1 *Installation of the Test Pieces and Lubricating Oil Specimen in the Test Chamber:*

9.1.1 Using solvent resistant gloves, clean the test ball, ball holder, and disk by wiping the surfaces with laboratory tissue soaked with the cleaning solvent (single boiling point spirit type 2-A in accordance with **DIN 51631:1999**. (**Warning**—This mixture is flammable and health hazard.) Repeat wiping until no dark residue appears on the tissue. Immerse the test ball and disk in a beaker of the cleaning solvent under ultrasonic vibration for 10 min. Dry the test ball and disk with a clean tissue to ensure no streaking occurs on the surface.

9.1.2 Ensure that the machine is unloaded (indicated by a load reading of -13 or -14 N), and install the ball holder (upper specimen holder).

9.1.3 Place the grease caliper with 1 mm in height on the cleaned disc. Fill the opening of the grease caliper with grease. Remove any excess grease by means of a spatula. Remove the grease caliper by lifting it upwards. Fasten the disc in the specimen holder.

9.1.4 Place the cleaned test ball on the top and in the middle of the lubricating grease specimen so that the lubricating grease makes a circular symmetric pad between the test ball and disk.

9.1.5 Tighten the fastening screw until resistance just begins.

9.2 Test Run:

9.2.1 *Start of the Test Run*—Turn on the heater control, and preheat the disk holder to 50°C . Allow 10 min for the test pieces and test grease to reach and stabilize at the test temperature. The test can be run at constant temperatures selected in $+10$ K ($+10^{\circ}\text{C}$) increments starting at $+233$ K to $+423$ K (-40°C to $+150^{\circ}\text{C}$).

NOTE 4—An initial hardness of 62.5 HRC at room temperature of AISI 52100 will drop to 61 HRC after 100 h at 149°C and will exist as a hot hardness of 60 HRC over 100 h.⁷

9.2.2 Apply a load of 50 N, loosen the fastening screws on both disk and ball holders, and then immediately tighten them with a torque wrench to 2.2 to 2.5 Nm.

9.2.3 When the temperature has stabilized, turn on the chart recorder paper feed (or the computer) and lower the recording pens. Depress the drive start toggle switch until the timer begins to count and then adjust the stroke amplitude knob to 0.300 mm (300 μm).

NOTE 5—Stroke should be checked periodically by measuring the wear track length minus the ball scar diameter. The difference must be smaller than $\pm 10\%$ of the set stroke.

9.2.4 When the digital timer reaches 30 s, increase the load to 100 N of normal force and run at that load for 4 h \pm 15 s.

9.2.5 For SRV III and IV models only In the SRV basic software, enter the following test parameters:

Frequency = 50 Hz

Stroke = 0.3 mm (300 μm)

Temperature = 50°C

Load 50 N for 30 s, then increase load to 100 N

Test duration = 240 min

To fully tighten the specimen combination, follow the instructions of the SRV software.

9.2.6 Terminating the Test Run:

9.2.6.1 The test is automatically terminated by the timer when the preset test time has elapsed. The machine will automatically stop.

NOTE 6—Power automatically turns off at the end of the test.

NOTE 7—If, due to seizure, the friction coefficient exceeds the limit of, for example, $f = 0.35$, the test should be terminated (see 3.2.3). If the machine does not automatically shut down at this point, it may have to be switched off manually.

9.2.6.2 At the end of the test, turn off the heater control, turn power back on, and reduce the load to -13 or -14 N for disassembly.

9.2.6.3 Remove and clean the test ball and disk in accordance with 9.1.1.

9.3 Evaluation:

9.3.1 Place the cleaned test ball on a suitable holder and, using a microscope, measure to the nearest 0.005 mm (5 μm) the scar width in the direction of sliding (d_1) and again at 90° to the direction of sliding (d_2). The mean or average wear scar diameter (WSD or W_k) is the average of these two measurements ($WSD = (d_1 + d_2)/2$). If the wear scar diameter is smaller than 1.1 times the Hertzian contact diameter, the profile of the wear scar in the center should be measured in order to calculate the wear volume W_v . If the wear scar diameter is greater than 1.1 times the Hertzian contact diameter, only the wear scar diameter should be reported (see Test Method **D6425**). The wear volume W_v (mm^3) should be used.

NOTE 8—An optional way to present the wear data is to calculate the wear volume W_v . A procedure for measuring the wear profile and calculating the wear volume is described in **DIN 51834-3:2008-12**, Part 3. An official English translation of this procedure is in preparation by DIN.³

9.3.2 Although not specifically part of the procedure, when additional wear analysis is required, perform a profilometric trace across the wear scar on the test disk in accordance with the profilometer manufacturer's instructions (See **DIN 51834-3:2008-12**).

9.3.3 Measure the minimum and maximum coefficients of friction (f_{min} , f_{max}) and the coefficients four times per hours (at 15, 30, 45 and 60 min) from the chart recorder graph or computer, with a precision of 0.001.

9.3.4 If strong fluctuations (band width ≥ 0.005) in the coefficient of friction are indicated on the chart recorder or other output device adjacent to the point at which the coefficient is measured, record the mean value and the magnitude of the fluctuations at that point (see Test Method **D6425**).

9.3.5 The load carrying capacity can be additionally reported as geometric contact pressure P_{geom} at test end in accordance with the following equation:

⁷ Zaretsky, E. V., "Tribology for Aerospace Applications," *STLE SP-37*, 1997, p. 358.