



Designation: ~~D4145-83(Reapproved2002)~~ Designation: D4145 - 10

## Standard Test Method for Coating Flexibility of Prepainted Sheet<sup>1</sup>

This standard is issued under the fixed designation D4145; the number immediately following the designation indicates the year of original adoption or, in the case of revision, the year of last revision. A number in parentheses indicates the year of last reapproval. A superscript epsilon ( $\epsilon$ ) indicates an editorial change since the last revision or reapproval.

### 1. Scope

1.1 This test method describes a procedure for determining the flexibility and adhesion of organic coatings (paints) on metallic substrates that are deformed by bending when the sheet is fabricated into building panels or other products.

1.2 The metal substrate must be capable of passing this test without fracturing and with no excessive grain development.

~~1.3 The values stated in inch-pound units are to be regarded as the standard. The values given in parentheses are for information only.~~

1.3 The values stated in inch-pound units are to be regarded as standard. The values given in parentheses are mathematical conversions to SI units that are provided for information only and are not considered standard.

1.4 *This standard does not purport to address all of the safety concerns, if any, associated with its use. It is the responsibility of the user of this standard to establish appropriate safety and health practices and determine the applicability of regulatory limitations prior to use.*

### 2. Terminology

2.1 *Definitions of Terms Specific to This Standard:*

2.1.1 *T-bend, n*—a description of the severity of a bend in terms of the gauge or thickness ( $T$ )( $t$ ) of the sheet to which the coating has been applied; *as used in this test method*, the T-bend rating is the minimum number of thicknesses of metal around which the coated sheet is bent (Fig. 1), or if bent around a die, the number of thicknesses of metal equivalent to the diameter of the die to achieve no fracture or removal of the coating.

### 3. Summary of Test Method

~~3.1 Prepainted panels are bent 180° around progressively more thicknesses of metal or larger diameter dies, the end point being when failures no longer occur. The panels are examined at low magnification (5 to 10×) after each bend for fracture of the coating (cracking) and, for loss of adhesion pickoff, by means of a tape pull-off test.~~

3.1 Prepainted panels are bent 180° around progressively more thicknesses of metal or larger diameter dies, the end point being when failures no longer occur. The panels may be examined with or without low magnification (5 to 10×) after each bend in order to determine if the coating fractured (cracked). If loss of adhesion or pickoff is to be determined, this examination shall occur after performing a tape pull-off test.

### 4. Significance and Use

4.1 Organic coatings on precoated sheet are subjected to stresses when fabricated into products by roll forming, brake bending, or other deformation processes. These stresses can exceed the flexibility or adhesive strength of the coating, resulting in fracture of the coating, ~~exposing coating which exposes the substrate, or in the loss of adhesion of the coating to the substrate.~~ This test is a means of evaluating the ability of a coating system to withstand the stresses of fabrication.

4.2 The bend direction, whether the axis of bend is ~~across-transverse to~~ or along the rolling diameter direction of the metal, and the temperature of the specimen when it is bent can affect the results of this test and should be agreed upon between the supplier and the user.

### 5. Apparatus

~~5.1 A means of holding one end of the specimen rigidly while making the bend is needed. A bench vise with smooth jaws or with smooth inserts, preferably of a soft metal to avoid damage to the coating, has been found to be satisfactory.~~

<sup>1</sup> This test method is under the jurisdiction of ASTM Committee D01 on Paint and Related Coatings, Materials, and Applications and is the direct responsibility of Subcommittee D01.53 on Coil Coated Metal.

Current edition approved May 10, 2002. Published May 2002. DOI: 10.1520/D4145-83R02.

Current edition approved June 1, 2010. Published August 2010. Originally approved in 1983. Last previous edition approved in 2002 as D 4145 - 83 (2002). DOI: 10.1520/D4145-10.

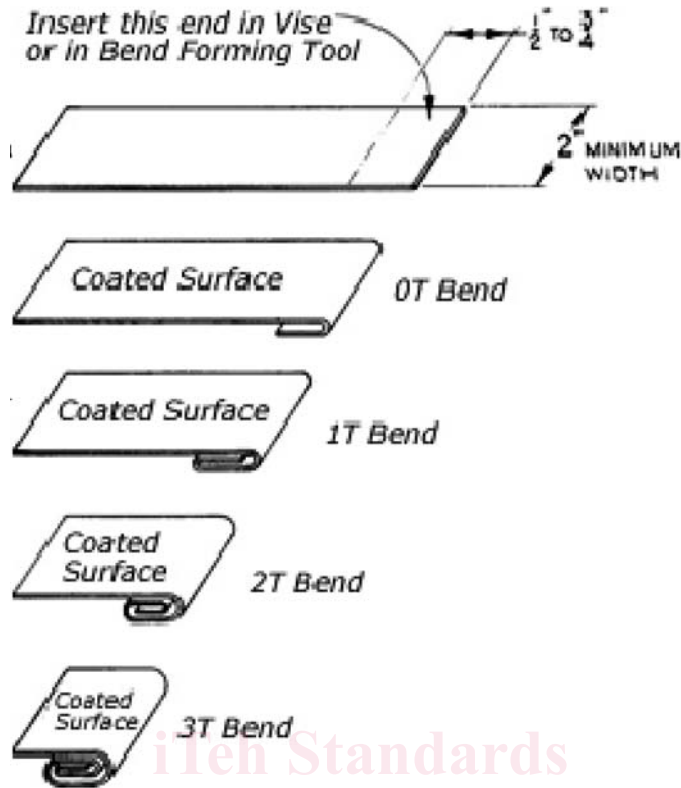

NOTE 1—The above bends are expanded for clarity. They are actually flat against themselves in the test.

FIG. 1 T-Bend Test in Which the Coated Specimen is Bent Around Itself

5.1 A means of holding one end of the specimen rigidly while making the bend is needed. Damage to the coating while making the bend must be avoided. Various bending tools such as a vise with smooth jaws or with smooth inserts, a bend forming tool (Fig. 2), a brake press (Fig. 3) or a combination of tools have been found to be satisfactory.

5.2 If the metal is not bent around itself as in Fig. 1, a series of bending dies with smoothly rounded ends may be used as guides around which the specimen is bent (Fig. 4).

5.3 Bend Forming Tool.

5.3.1 A manual or automated operation forming tool capable of facilitating the T-bending of a sample may be used. An arbor press with an appropriate fixed V-shaped die and moveable wedge has been found to be satisfactory for this purpose.

5.4 Magnifier.

5.4.1 A magnifier capable of 5 to 10× magnification for examining the specimen for coating fracture and pickoff after testing. A stereomicroscope has been found useful for this purpose.

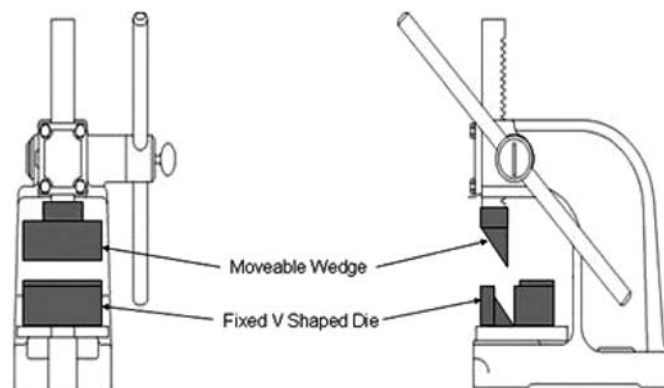

FIG. 2 Bend Forming Tool for Performing T-Bends