



SLOVENSKI STANDARD

SIST EN 300 931 V6.0.1:2003

01-december-2003

8 [[[HJb]`W] b]`h`Y_ca i b]_UW`g_]`g]ghYa `fZuU&ZL`E`HY b] bUfYU]nUWU
ZJ_g]a]bY`g_i d]bY' `hfUbgdUfYbhif} GA `\$' `() žfUn`]WU* '\$`%Z]nXUU% - +Ł

Digital cellular telecommunications system (Phase 2+) (GSM); Technical realization of facsimile group 3 transparent (GSM 03.45 version 6.0.1 Release 1997)

iteh STANDARD PREVIEW
(standards.iteh.ai)

Ta slovenski standard je istoveten z: **EN 300 931 Version 6.0.1**

SIST EN 300 931 V6.0.1:2003
<https://standards.iteh.ai/catalog/standards/sist/4c608ecc-1185-4ad1-81/a-7c80d88c75a7/sist-en-300-931-v6-0-1-2003>

ICS:

33.070.50	Globalni sistem za mobilno telekomunikacijo (GSM)	Global System for Mobile Communication (GSM)
-----------	---	--

SIST EN 300 931 V6.0.1:2003

en

iTeh STANDARD PREVIEW
(standards.iteh.ai)

[SIST EN 300 931 V6.0.1:2003](https://standards.iteh.ai/catalog/standards/sist/4e8b8eec-1f83-4adf-8f7a-7c80d88c75a7/sist-en-300-931-v6-0-1-2003)

<https://standards.iteh.ai/catalog/standards/sist/4e8b8eec-1f83-4adf-8f7a-7c80d88c75a7/sist-en-300-931-v6-0-1-2003>

EN 300 931 V6.0.1 (1999-09)

European Standard (Telecommunications series)

Digital cellular telecommunications system (Phase 2+); Technical realization of facsimile group 3 transparent (GSM 03.45 version 6.0.1 Release 1997)

iTeh STANDARD PREVIEW
(standards.iteh.ai)

GSM®
GLOBAL SYSTEM FOR
MOBILE COMMUNICATIONS

[SIST EN 300 931 V6.0.1:2003](https://standards.iteh.ai/catalog/standards/sist/4e8b8eec-1f83-4adf-8f7a-7c80d88c75a7/sist-en-300-931-v6-0-1-2003)

<https://standards.iteh.ai/catalog/standards/sist/4e8b8eec-1f83-4adf-8f7a-7c80d88c75a7/sist-en-300-931-v6-0-1-2003>



Reference

DEN/SMG-040345Q6 (8mc0300o.PDF)

Keywords

Digital cellular telecommunications system,
Global System for Mobile communications (GSM)

ETSI

Postal address

F-06921 Sophia Antipolis Cedex - FRANCE

Office address

650 Route des Lucioles - Sophia Antipolis
Valbonne - FRANCE

Tel.: +33 4 92 94 42 00 Fax: +33 4 93 65 47 16

Siret N° 348 623 562 00017 - NAF 742 C

Association à but non lucratif enregistrée à la
Sous-Prefecture de Grasse (06) N° 7803/88

Internet

secretariat@etsi.fr

Individual copies of this ETSI deliverable
can be downloaded from

<http://www.etsi.org>

If you find errors in the present document, send your
comment to: editor@etsi.fr

Copyright Notification

No part may be reproduced except as authorized by written permission.
The copyright and the foregoing restriction extend to reproduction in all media.

© European Telecommunications Standards Institute 1999.
All rights reserved.

Contents

Intellectual Property Rights.....	5
Foreword	5
0 Scope	6
0.1 References.....	6
0.2 Definitions and abbreviations	7
1 Service definition	8
2 Network architecture.....	8
3 Reference configuration at the mobile station	9
3.1 Fax Adaptor functionality	10
3.2 GSM Facsimile Machine functionality	10
4 Connection types.....	11
4.1 Information transfer protocol model	12
4.2 Interactions with T.30	13
4.2.1 Link control strategy	13
4.2.1.1 Message detection.....	14
4.2.2 Speed conversion for BCS phases.....	14
4.2.3 Compatibility checking	15
4.2.3.1 Group 1 and Group 2 support.....	15
4.2.3.2 2 400 bit/s handshaking.....	15
4.2.3.3 Non-standard facilities.....	15
4.2.3.4 12 000 and 7200 bit/s Facsimile Document Transfer.....	15
4.2.3.5 Procedure interrupts.....	15
4.2.4 Speed checking.....	15
4.3 Radio Channel Modification Procedures.....	16
4.3.1 In Call Modification (ICM).....	16
4.3.2 Channel Mode Modify (CMM).....	17
5 Use of terminal adaptation functions	18
5.1 Standard TAFs for synchronous services.....	18
5.2 Specific TAFs for facsimile service.....	18
5.2.1 Working principle	18
5.2.2 Basic protocol structure.....	19
5.2.2.1 Frame formats.....	19
5.2.3 Protocol description	20
5.2.3.1 IDLE state.....	20
5.2.3.2 BCS-REC state	20
5.2.3.3 BCS-TRA state.....	20
5.2.3.4 MSG-REC state.....	21
5.2.3.5 MSG-TRA state.....	21
5.2.4 DCS and TCF processing.....	21
5.2.5 DCN (disconnect) frame	22
5.2.6 Clocking	22
5.2.7 Timeouts.....	22
5.3 Specific TAFs for facsimile service (T.30/A).....	23
5.3.1 Frame detection.....	23
5.3.2 Message phase.....	23
5.3.3 Additional CMM request	23
6 Signalling aspects.....	23
6.1 Handling of Tonal Signals	24
6.2 Call establishment.....	24
6.2.1 Mobile Terminated Call - Speech then Fax.....	24
6.2.2 Mobile Terminated Call - Auto answer.....	24
6.2.3 Mobile Originated Call - Speech then Fax	25

6.2.4	Mobile Originated Call - Auto calling.....	25
6.2.5	Mobile Originated Call - Manual calling	25
6.3	Call release.....	26
7	Interworking to fixed networks.....	26
7.1	Interworking to PSTN.....	26
7.2	Interworking to ISDN	27
Annex I (informative):	Protocol entities from CCITT T.30 and T.4	28
Annex II (informative):	Procedure examples.....	29
Annex III (informative):	Change Request History	42
History		43

iTeh STANDARD PREVIEW (standards.iteh.ai)

[SIST EN 300 931 V6.0.1:2003](https://standards.iteh.ai/catalog/standards/sist/4e8b8eec-1f83-4adf-8f7a-7c80d88c75a7/sist-en-300-931-v6-0-1-2003)

<https://standards.iteh.ai/catalog/standards/sist/4e8b8eec-1f83-4adf-8f7a-7c80d88c75a7/sist-en-300-931-v6-0-1-2003>

Intellectual Property Rights

IPRs essential or potentially essential to the present document may have been declared to ETSI. The information pertaining to these essential IPRs, if any, is publicly available for **ETSI members and non-members**, and can be found in SR 000 314: "*Intellectual Property Rights (IPRs); Essential, or potentially Essential, IPRs notified to ETSI in respect of ETSI standards*", which is available **free of charge** from the ETSI Secretariat. Latest updates are available on the ETSI Web server (<http://www.etsi.org/ipr>).

Pursuant to the ETSI IPR Policy, no investigation, including IPR searches, has been carried out by ETSI. No guarantee can be given as to the existence of other IPRs not referenced in SR 000 314 (or the updates on the ETSI Web server) which are, or may be, or may become, essential to the present document.

Foreword

This European Standard (Telecommunications series) has been produced by the Special Mobile Group (SMG).

The present document defines the technical realization of facsimile group 3 using transparent network support within the digital cellular telecommunications system.

The contents of the present document is subject to continuing work within SMG and may change following formal SMG approval. Should SMG modify the contents of the present document it will be re-released with an identifying change of release date and an increase in version number as follows:

Version 6.x.y

where:

- 6 indicates Release 1997 of GSM Phase 2+
- x the second digit is incremented for all changes of substance, i.e. technical enhancements, corrections, updates, etc.
- y the third digit is incremented when editorial only changes have been incorporated in the specification.

The specification from which the present document has been derived was originally based on CEPT documentation, hence the presentation of the present document may not be entirely in accordance with the ETSI/PNE Rules.

Proposed national transposition dates

Date of adoption of this EN:	3 September 1999
Date of latest announcement of this EN (doa):	31 December 1999
Date of latest publication of new National Standard or endorsement of this EN (dop/e):	30 June 2000
Date of withdrawal of any conflicting National Standard (dow):	30 June 2000

0 Scope

The present document deals with the procedures allowing the technical realization of the Group 3 facsimile Service within the GSM PLMN using transparent Network support, according to the definition of Teleservice 61 and 62 specified in the GSM 02.03 [2].

0.1 References

The following documents contain provisions which, through reference in this text, constitute provisions of the present document.

- References are either specific (identified by date of publication, edition number, version number, etc.) or non-specific.
- For a specific reference, subsequent revisions do not apply.
- For a non-specific reference, the latest version applies.
- A non-specific reference to an ETS shall also be taken to refer to later versions published as an EN with the same number.
- For this Release 1997 document, references to GSM documents are for Release 1997 versions (version 6.x.y).

- [1] GSM 01.04: "Digital cellular telecommunication system (Phase 2+): "Abbreviations and acronyms".
- [2] GSM 02.03: "Digital cellular telecommunication system (Phase 2+); Teleservices supported by a GSM Public Land Mobile Network (PLMN)".
- [3] GSM 02.34: "Digital cellular telecommunications system (Phase2+): High Speed Circuit Switched Data (HSCSD) - Stage1".
- [4] GSM 03.10: "Digital cellular telecommunication system (Phase 2+); GSM Public Land Mobile Network (PLMN) connection types".
- [5] GSM 03.34: "Digital cellular telecommunications system (Phase2+): High Speed Circuit Switched Data (HSCSD) - Stage2.
- [6] GSM 04.02: "Digital cellular telecommunication system (Phase 2+); GSM Public Land Mobile Network (PLMN) access reference configuration".
- [7] GSM 04.08: "Digital cellular telecommunication system (Phase 2+); Mobile radio interface layer 3 specification".
- [8] GSM 04.21: "Digital cellular telecommunication system (Phase 2+); Rate adaption on the Mobile Station - Base Station System (MS - BSS) interface".
- [9] GSM 07.01: "Digital cellular telecommunication system (Phase 2+); General on Terminal Adaptation Functions (TAF) for Mobile Stations (MS)".
- [10] GSM 07.03: "Digital cellular telecommunication system (Phase 2+); Terminal Adaptation Functions (TAF) for services using synchronous bearer capabilities".
- [11] GSM 09.07: "Digital cellular telecommunication system (Phase 2+); General requirements on interworking between the Public Land Mobile Network (PLMN) and the Integrated Services Digital Network (ISDN) or Public Switched Telephone Network (PSTN)".
- [12] CCITT Recommendation T.35: "Procedure for the allocation of CCITT members' codes".
- [13] CCITT Recommendation F.160 Fascicle II.5: "General operational provision for the international public facsimile".

- [14] CCITT Recommendation T.4 Fascicle VII.3: "Standardization of group 3 facsimile apparatus for document transmission".
- [15] CCITT Recommendation T.30 Fascicle VII.3: "Procedures for document facsimile transmission in the general switched telephone network".
- [16] CCITT Recommendation V.21 Fascicle VIII.1: "300 bits per second duplex modem standardized for use in the general switched telephone network".
- [17] CCITT Recommendation V.24 Fascicle VIII.1: "List of definitions for interchange circuits between data terminal equipment (DTE) and data circuit-terminating equipment (DCE)".
- [18] CCITT Recommendation V.25bis Fascicle VIII.1: "Automatic calling and/or answering equipment on the general switched telephone network (GSTN) using the 100-series interchange circuits".
- [19] CCITT Recommendation V.27ter Fascicle VIII.1: "4 800/2 400 bits per second modem standardized for use in the general switched telephone network".
- [20] CCITT Recommendation V.29 Fascicle VIII.1: "9 600 bits per second modem standardized for use on point-to-point 4-wire leased telephone-type circuits".
- [21] CCITT Recommendation V.33 Fascicle VIII.1: "14 400 bits per second modem standardized for use on point-to-point 4-wire leased telephone-type circuits".
- [22] CCITT Recommendation X.300 Fascicle VIII.6: "General principles for interworking between public networks, and between public networks and other networks for the provision of data transmission services".
- [23] CCITT Recommendation V.17: "A 2-wire modem for facsimile applications with rates up to 14 400 bit/s".

(standards.iteh.ai)

0.2 Definitions and abbreviations

In addition to those below, abbreviations used in the present document are listed in GSM 01.04 [1].

BCS	Binary Coded Signalling phase of Facsimile transmission as per CCITT T.30
CT105	Interchange Circuit 105 as per CCITT V.24
CT106	Interchange Circuit 106 as per CCITT V.24
CT107	Interchange Circuit 107 as per CCITT V.24
CT108.2	Interchange Circuit 108/2 as per CCITT V.24
CT109	Interchange Circuit 109 as per CCITT V.24
CT114	Interchange Circuit 114 as per CCITT V.24
CT115	Interchange Circuit 115 as per CCITT V.24
FA/MT	The Fax Adaptor specifically located at MT side
FA/IWF	The Fax Adaptor specifically located at IWF side
MSG	Message phase of Facsimile transmission as per CCITT T.30

All protocol entities from CCITT Facsimile Recommendations (T.4 and T.30) apply; in the present document they are referenced to in the same way as in the above CCITT Recommendations (see also annex I to the present document).

1 Service definition

The fixed network Group 3 Facsimile service, as basically defined in CCITT Recommendation F.160, is an international telematic service for ISO A4 document transmission between two facsimile stations.

The service specification is comprised of two parts: the control protocol described in CCITT Recommendation T.30, and the document transmission coding described in CCITT Recommendation T.4.

The GSM facsimile Teleservice is intended to allow facsimile connections between group 3 apparatus using:

- a GSM PLMN as a stand alone facility, for mobile to mobile communication;
- a GSM PLMN to gain access to fixed networks PSTN and ISDN, for mobile to/from land communication.

For this Teleservice, the document coding is as CCITT Recommendation T.4 with no modifications. The protocol used is CCITT Recommendation T.30 modified within the PLMN as detailed in the present document.

The interworking between different networks is based on CCITT Recommendation X.300.

The particular features of this Teleservice are:

- it uses point-point communication;
- the information transfer capability is dual "Speech"/"Group 3 Facsimile" for Teleservice 61 and "Group 3 Facsimile" only for Teleservice 62;
- both mobile originated and terminated calls are supported;
- the information transfer mode is circuit, duplex, synchronous and symmetric;
- different end-to-end transfer rates are used within the same call to take advantage of the better radio path error rate;
- use of a standard synchronous terminal adaptation function (as per GSM 07.03) within the MS.

iTech STANDARD PREVIEW
(standards.iteh.ai)
SIST EN 300 931 V6.0.1:2003
<https://standards.iteh.ai/catalog/standards/sist/7c80d88c-1163-44df-817a-7c80d88c75a7/sist-en-300-931-v6-0-1-2003>

2 Network architecture

The network architecture applicable to this Teleservice is shown in figure 1/03.45, below.

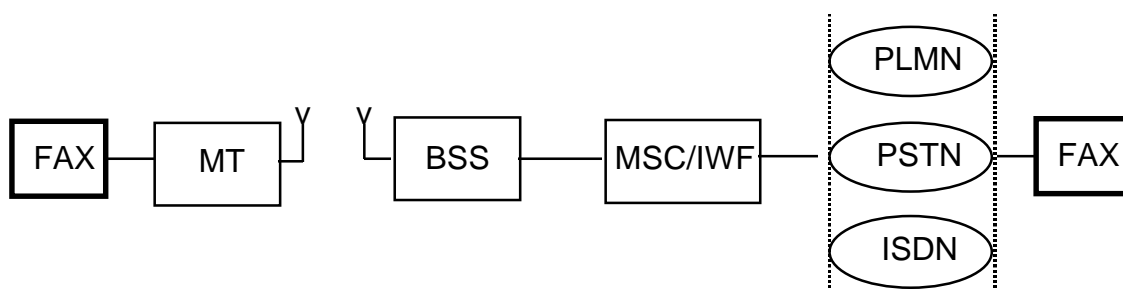

Figure 1/03.45: Network architecture

This shows the case of mobile to fixed network interworking. For mobile to mobile calls, there would effectively be a loop back within the PLMN, using two IWFs.

3 Reference configuration at the mobile station

The mobile reference configurations described in this clause are defined as per GSM 04.02.

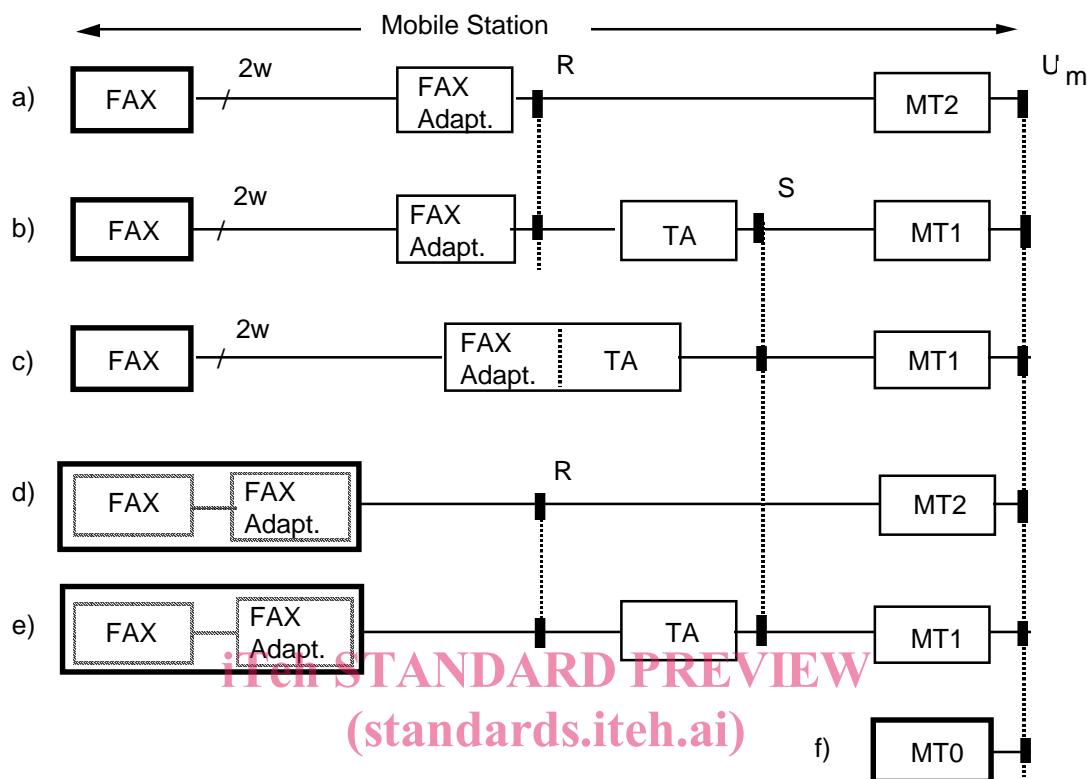

Figure 2/03.45: Reference configurations

The Teleservice definition in GSM 02.03 regards the group 3 facsimile terminal as a 2-wire analogue terminated equipment. In order to connect this to the MT2 a separate "Fax Adaptor" device is necessary.

This configuration, shown in figure 2a/03.45, has to be considered as the standard configuration, so that all the existing Group 3 facsimile apparatus can be connected to the PLMN.

An alternative realization would be to combine a standard group 3 facsimile machine and the Fax Adaptor into a specially developed "GSM facsimile machine", directly providing a digital output. Although such a device must appear to the MT2 as identical to the Fax Adaptor (i.e. with an identical interface and protocol), it would allow for a significantly smaller and simpler facsimile machine. This configuration is shown in figure 2d/03.45 and is regarded as a desirable alternative.

In addition of course, it is always possible to realize an MT0, as per figure 2f/03.45, where both the facsimile and mobile termination functions are considered to be part of one integrated unit.

The remaining configurations concern the use of an S interface and are considered as optional configurations. Their use is for further study.

The particular terminal adaptation functions used are those detailed in GSM 07.03 and the interface to the MT2 used is synchronous V.24 with an option for support of V.25bis procedures for autocalling and autoanswering.

3.1 Fax Adaptor functionality

The Fax Adaptor block, figure 3/03.45, is intended to specifically complement the Group 3 facsimile apparatus in order to be able to communicate over a GSM PLMN.

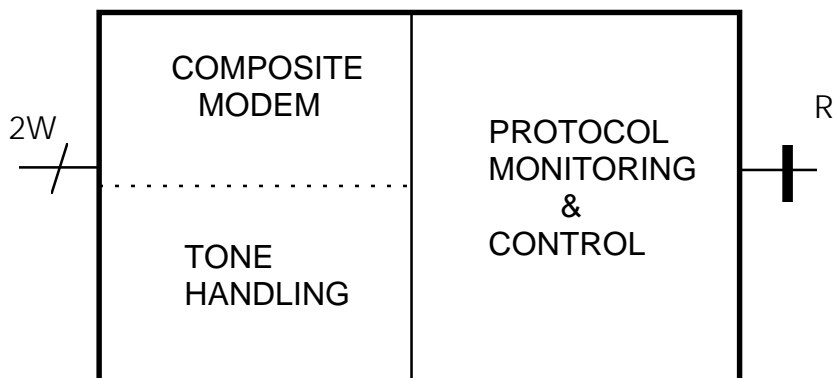

Figure 3/03.45: Fax Adaptor scheme

Whether it has to be a function internal to the GSM PLMN, or an external accessory associated with the Group 3 apparatus, is beyond the scope of the present document, and in any case, does not affect at all the working of the procedure as here described.

It can be functionally partitioned in two sections:

- an analogue section, dealing with:
 - the modulation and demodulation processes according to CCITT Recommendation V.21, V.27ter, V.29 and V.17 as explained in T.4 and T.30;
 - handling of the signalling on the 2-wire path to the facsimile machine, including autocalling and autoanswer functions where necessary (see clause 6);
- a digital section, dealing with:
 - monitoring and where necessary, manipulation of the T.30 protocol as detailed in the rest of the present document;
 - overall control of the adaptor;
 - connection over the synchronous V.24 interface to the MT as described in GSM 07.03;
 - where necessary, autocalling and autoanswering functions according to V.25bis.

In the following this specification will reference the Fax Adaptor functionality, considering the most general case where it operates as a full-featured (see figure 3/03.45) separate block (see figure 2a/03.45), as this reference configuration is implicitly or explicitly exhaustive of all service related technical aspects.

3.2 GSM Facsimile Machine functionality

The special GSM facsimile machine shown in the MS configuration of figure 2d/03.45 has a similar functionality to the digital part of the Fax Adaptor, but without any of the analogue portions.

It appears over the V.24 interface as identical to the Fax Adaptor, i.e. the MT2 needs to have no knowledge of the particular configuration used.

When necessary this reference configuration, will be explicitly referenced to in the following; otherwise all technical aspects relevant to the configuration implicitly apply.

4 Connection types

Table 1/03.45 shows the connection elements attributes applicable to this Teleservice (note), adapted from GSM 03.10.

NOTE: Teleservice 61 includes both speech and data connection types, but Teleservice 62 only the data connection type.

Table 1/03.45: Elements of connection types

Protocol type of Figure 6 of TS GSM 03.10	Access to TAF of the Mobile Station	Radio interface connection element	Intermediate rate RA1 to RA2	BS-MSC/IWF connection element
Model 6: Speech	-	Speech/GSM	-	CCITT A-law
Model 5: Facsimile Group 3	C/D/S UDI - 14.4 kbit/s - 9.6 kbit/s - 4.8 kbit/s - 2.4 kbit/s (note)	C/D/S UDI - 14.5 kbit/s - 12.0 kbit/s - 6.0 kbit/s - 3.6 kbit/s	C/D/S UDI - 16 kbit/s - 16 kbit/s - 8 kbit/s - 8 kbit/s	C/D/S UDI - 64 kbit/s - 64 kbit/s - 64 kbit/s - 64 kbit/s
Model 5b Facsimile Group 3	C/D/S UDI - 14.4 kbit/s - 9.6 kbit/s - 4.8 kbit/s - 2.4 kbit/s	C/D/S UDI 14,5 or 2X12 kbit/s 12 or 2X6 kbit/s 6 kbit/s 6 kbits	C/D/S UDI 16 or 2X16 kbit/s 16 or 2X8 kbits 8 kbit/s 8 kbit/s	C/D/S UDI - 64 kbit/s - 64 kbit/s - 64 kbit/s - 64 kbit/s

NOTE: The highest Access Rate actually supported in this teleservice will be consistent with the highest Access Rate of the Transparent Bearer Service provided by the Network Operator.

C = Circuit switched S = Synchronous

D = Full-duplex UDI = Unrestricted Digital Information

Table 1a/03.45

Fax modem rates	No. of substreams	Radio i/f rate	Intermediate Rate	Padding Scheme
14.4 kbit/s	1	14,5 kbit/s	16 kbit/s	
	2	12 kbit/s	16 kbit/s	
12.0 kbit/s	1	14,5 kbit/s	16 kbit/s	FA(5D + S)
	2	12 kbit/s	16 kbit/s	FA(5D + S)
9.6 kbit/s	1	12 kbit/s	16 kbit/s	
	2	6 kbit/s	8 kbit/s	
7.2 kbit/s	1	12 kbit/s	16 kbit/s	FA(3D + S)
	2	6 kbit/s	8 kbit/s	FA(3D + S)
4.8 kbit/s	1	6 kbit/s	8 kbit/s	
2.4 kbit/s	1	6 kbit/s	8 kbit/s	

FA = Padding is performed in the FA

(nD + mS) means that m SYNC frames will be added every n'th DATA frame

The MS must support the combinations in table 1a/03.45, restricted to what has been negotiated between the MS and the network.

All transitions from one combination in table 1a/03.45 to another combination in the same table, must be supported by the MS, as long as the fax modem rate is kept constant or the transition of fax modem rate is performed in steps of 2,4 kbit/s.

The figure 4/03.45 shows the scheme of a typical GSM PLMN connection for this Teleservice, considering respectively R and S access at Network Termination.